



S3515

CMOS IC

PC POWER SUPPLY SUPERVISORS

DESCRIPTION

The UTC **S3515** is specially designed for switching power supply system. It provides over-voltage protection, over-current protection, under-voltage protection, on/off control and power good signal generating.

OVP/UVP (Over/Under-Voltage Protection) monitors 3.3V, 5V and double 12V to protect our power supply and PC, FPO goes to high when one of these supply voltages exceeds their normal operation voltage range.

OCP (Over Current Protection) monitors IS33, IS5, IS12 input current. The voltage difference across external current shunt is used for OCP functions. An external resistor which is connected between the RI pin and the GND pin can be used to adjust protection threshold. To achieve better immunity for lightning surge glitch and to prevent accidental power shut down during dynamic loading condition, the de-bounce time for UVP/OCP is 73us respectively. The deglitch time for OVP is 73uS for better noise immunity.

The power supply is turned on after 38mS de-bounce time when PSON signal is set from high to low. To turn off power supply, PSON signal is set from low to high and the de-bounce time is 115mS. When PGI input voltage level is lower than the internal 1.15V reference voltage, after 73uS de-bounce time, the PGO signal is pulled low.

FEATURES

- * Over/Under-Voltage Protection for 3.3V, 5V, and Two 12V
- * Over-Current Protection for 3.3V, 5V, and Two 12V
- * PGO and FPO pins with Open Drain Output Stage
- * 300mS Power Good Delay from PGI to PGO
- * 75mS Delay for 3.3V, 5V and 12V Power Turn on
- * 2.8mS Delay for PSON Control to FPO Turn off
- * 38mS / 115mS PSON on/off De-Bounce Time
- * 73uS width Noise Deglitches
- * 73uS De-Bounce Time for UVP and OCP
- * Wide Supply Voltage Range

ORDERING INFORMATION

Ordering Number		Package	Packing
Lead Free Plating	Halogen Free		
S3515L-D14-T	S3515G-D14-T	DIP-14	Tube
S3515L-S14-R	S3515G-S14-R	SOP-14	Tape Reel
S3515L-S14-T	S3515G-S14-T	SOP-14	Tube

<p>S3515G-D14-T</p> <p>(1)Packing Type (2)Package Type (3)Halogen Free</p>	<p>(1) R: Tape Reel, T: Tube (2) D14: DIP-14, S14: SOP-14 (3) G: Halogen Free, L: Lead Free Plating</p>
--	---

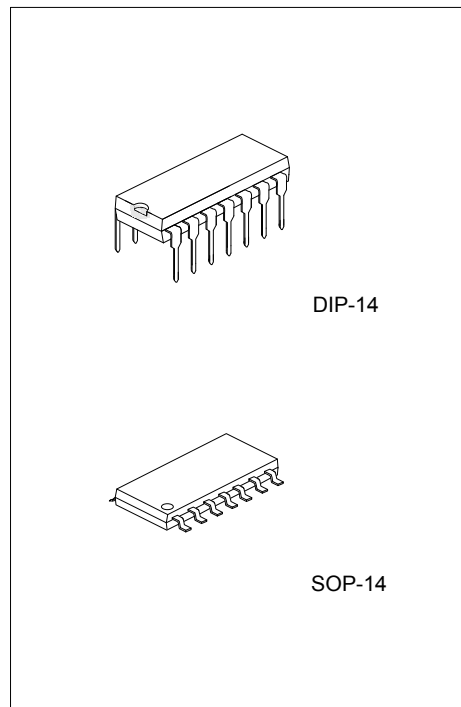

■ PIN CONFIGURATION

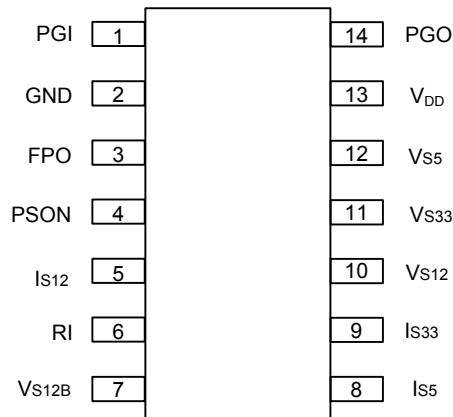

■ PIN DESCRIPTION

PIN NO	PIN NAME	TYPE	DESCRIPTION
1	PGI	input	Power good input.
3	FPO	output	Fault protection output, open drain output stage.
4	PSON	input	Power on/off control signal sends from CPU or main-board. The power supply will be turned on/off after 38mS/115mS respectively.
8	IS5	input	5V over current protection.
9	IS33	input	3.3V over current protection.
5	IS12	input	12V over current protection. Regarding typical application, this pin is connected to the positive end of a current shunt through one resistor. When the voltage on IS12 is higher than that of VS12 by 5mV, OCP will be enabled. One current sink, $8 \times I_{REF}$, is used to determine the voltage drop between the positive end of the current shunt and VS12. Adjusting the value of the external resistor can adjust the threshold for OCP accordingly. The operation for IS5 or IS33 is the same.
6	RI	input	Current sense setting. An external resistor Ri is connected between RI pin and GND pin will adjust a reference current, $I_{REF} = 1.15/Ri$, for OCP function.
12	VS5	input	5V over/under-voltage protection.
7	VS12B	input	Second 12V over/under-voltage protection.
10	VS12	input	12V over/under-voltage protection.
11	VS33	input	3.3V over/under-voltage protection.
13	VDD	power	Supply voltage. 4V ~ 15V.
14	PGO	output	Power good logic output, open drain output stage. The power good delay is 300mS from PGI to PGO.
2	GND	power	Ground.

■ BLOCK DIAGRAM

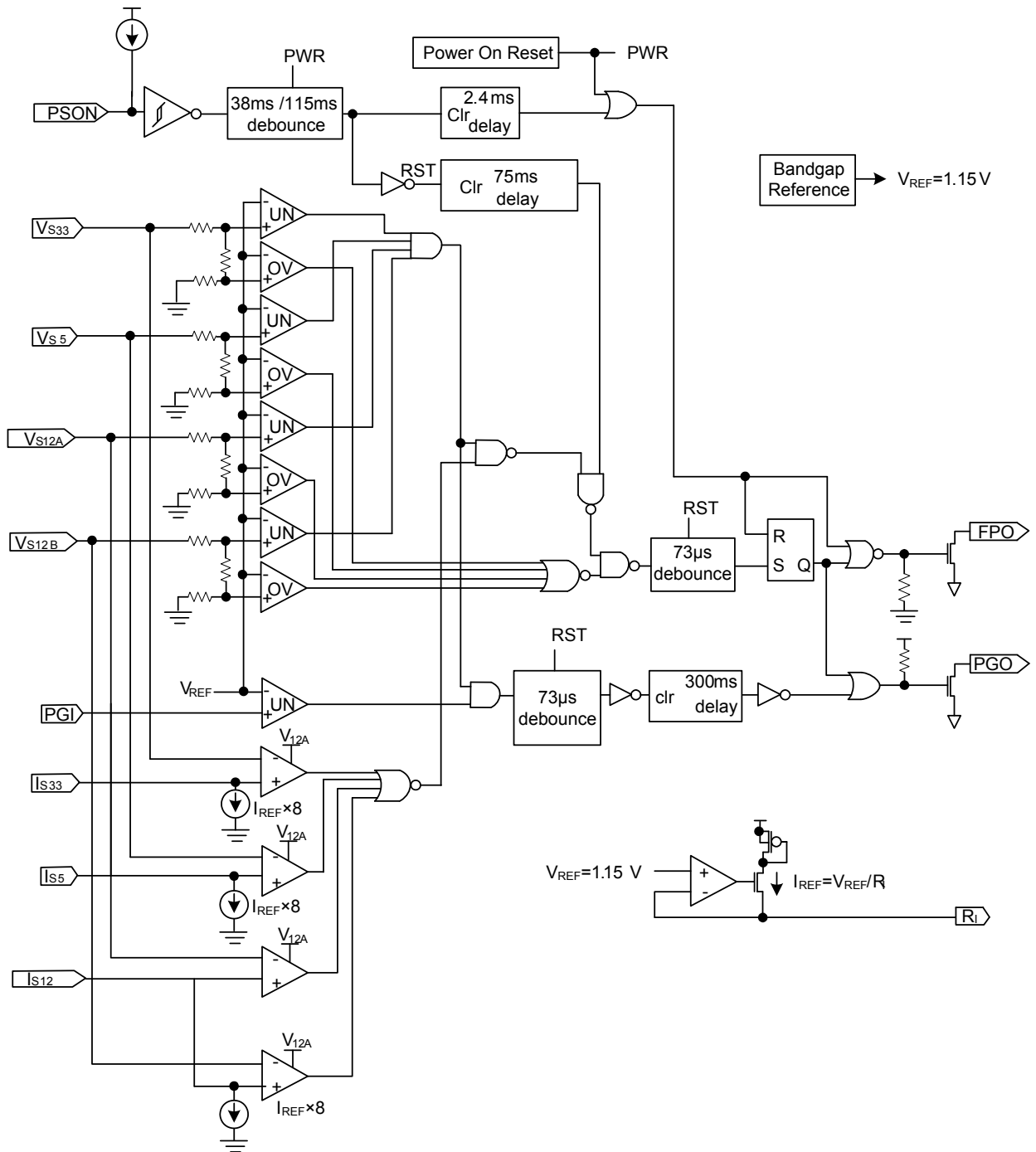

■ ABSOLUTE MAXIMUM RATING

PARAMETER	SYMBOL	RATINGS	UNIT
DC Supply Voltage	V_{DD}	-0.3 ~ 16	V
Input Voltage (PSON, V_{S33} , V_{S5} , PGI)	V_{IN}	-0.3 ~ 8	V
Output Voltage (FPO)	V_{OUT}	-0.3 ~ 16	V
		-0.3 ~ 8	
Power Dissipation (PGO)	P_D	400	mW
Operating Temperature	T_{OPR}	-40 ~ +85	°C
Storage Temperature	T_{STG}	-55 ~ +150	°C

Note 1. Absolute maximum ratings are those values beyond which the device could be permanently damaged.

Absolute maximum ratings are stress ratings only and functional device operation is not implied.

2. Stresses above those listed may cause permanent damage to the device.

■ RECOMMENDED OPERATING CONDITIONS

PARAMETER	SYMBOL	RATINGS	UNIT
DC Supply Voltage	V_{DD}	4 ~ 15	V
Input Voltage (PSON, V_{S33} , V_{S5} , I_{S33} , I_{S5} , PGI)	V_{IN}	7	V
Input Voltage (V_{S12} , V_{S12B} , I_{S12})		15	
Output Voltage	V_{OUT}	15	V
		7	
Output Sink Current	$I_{O(SINK)}$	20	mA
		10	
Supply Voltage Rising Time (Note)	t_R	1	mS
Output Current RI	I_{RI}	12.5 ~ 62.5	μ A

Note V_{DD} rising and falling slew rate must be less than 14V/mS.

■ ELECTRICAL CHARACTERISTICS ($V_{DD}=12V$, $T_A=25^\circ C$)

PARAMETER	SYMBOL	TEST CONDITIONS	MIN	TYP	MAX	UNIT	
UNDER-VOLTAGE AND PGI, PGO							
Input Threshold Voltage PGI	V_{PGI}		1.1	1.15	1.2	V	
Under-voltage protect V_{S33}	V_{UVP}		2.6	2.8	3.0	V	
Under-voltage protect V_{S5}			4.0	4.2	4.4		
Under-voltage protect V_{S12} , V_{S12B}			9.4	9.9	10.4		
Low Level Output Voltage (PGO)	V_{OL}	$V_{DD} = 12V$ $I_{SINK} = 10mA$			0.7	V	
Leakage Current (PGO)	I_{LEAK}	PGO = 5V			5	μ A	
Under-voltage Enable Delay Time			49	75	114	mS	
Timing PG Delay	PGI to PGO	t_{PG}	200	300	450	mS	
Noise Deglitch Time	PGI to PGO		150	250	350	μ S	
Timing UVP to Protection (FPO)	T_{UVP}	$V_{S33}, V_{S5}, V_{S12}, V_{S12B}$		73		μ S	
OVER-VOLTAGE AND OVER-CURRENT PROTECTION							
Over-Voltage Protection	V_{S33}	V_{OVP}		3.7	3.9	4.1	V
Over-Voltage Protection	V_{S5}			5.7	6.1	6.5	
Over-Voltage Protection	V_{S12}, V_{S12B}			13.2	13.8	14.4	
Ratio of Current Sense Sink Current to Current Sense Setting Pin (RI) Source Current	I_{REF}	RI = 30 K Ω , 0.1% Resistor	7.6	8	8.4		
Current Source Reference Voltage	V_{REF}		1.1	1.15	1.2	V	
OCP Comparator Input Offset Voltage	$V_{I(OFF)}$		-5		5	mV	
Low Level Output Voltage (FPO)	V_{OL}	$I_{SINK} = 20mA$			0.7	V	
Leakage Current (FPO)	I_{LEAK}	$V_{(FPO)} = 5V$			5	μ A	
Timing OVP to Protection	T_{OVP}			73		μ S	
Timing OCP to Protection	T_{OCP}			73		μ S	

■ ELECTRICAL CHARACTERISTICS(Cont.)

PARAMETER	SYMBOL	TEST CONDITIONS	MIN	TYP	MAX	UNIT
PSON CONTROL						
High-Level Input Voltage	V_{IH}		1.9			V
Low-Level Input Voltage	V_{IL}				0.98	V
Timing PGO Low to FPO High	T_{PSOFF}		1.6	2.8	4.0	mS
Timing PSON to On/Off	ON	T_{PSON}	24	38	57	mS
	OFF		24	38	57	mS
Input Pull-up Current	I_{PSON}	PSON = 0V		120		μ A
TOTAL DEVICE						
Supply Current	I_{DD}	PSON = 5V, V_{DD} = 5V		1.0	1.8	mA
V_{DD} Start Threshold Voltage	V_{THD}				4.0	V
V_{DD} Min. Operation Voltage After Start-up	V_{MIN}		3.65			V

■ TYPICAL APPLICATION CIRCUIT

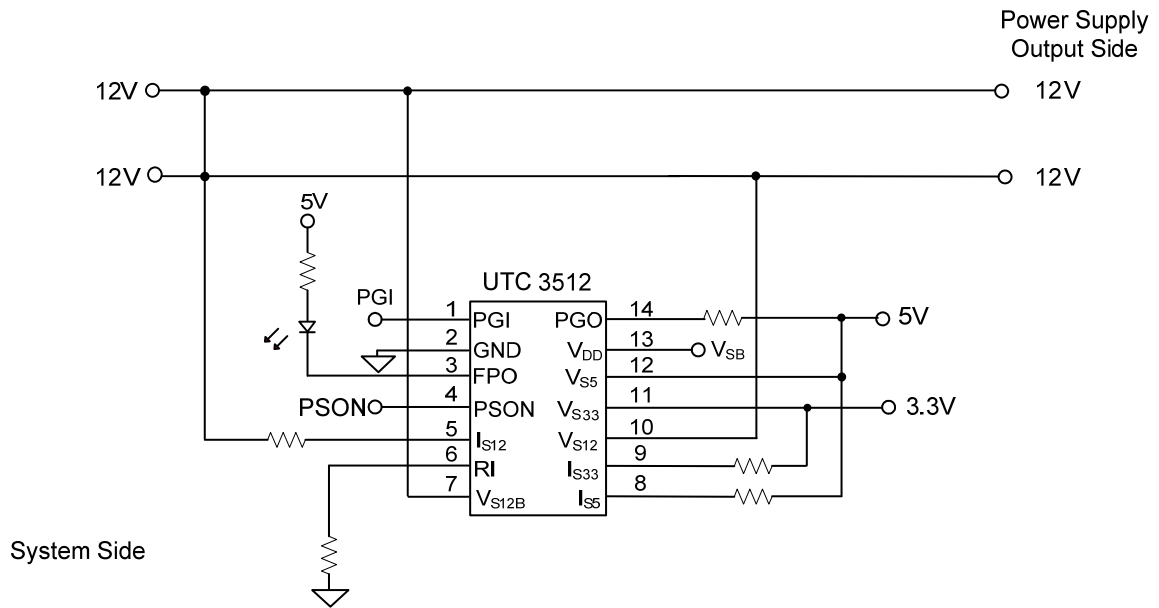

■ TIMING DIAGRAM

PSON On/Off and 3.3V, 5V, 12V OVP Function

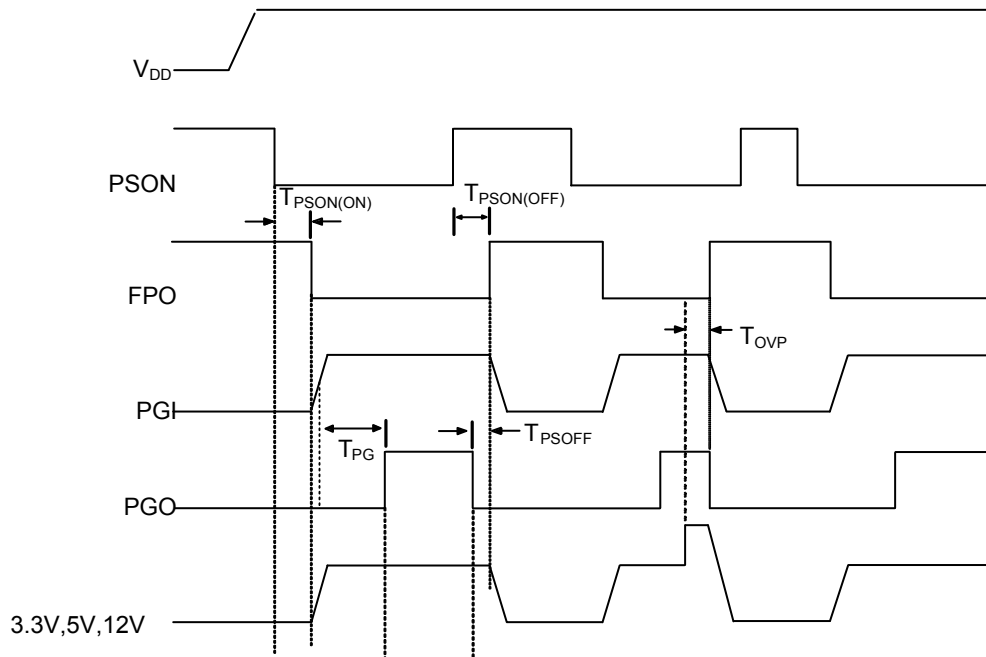

3.3V, 5V, 12V OVP UVP and OCP Function

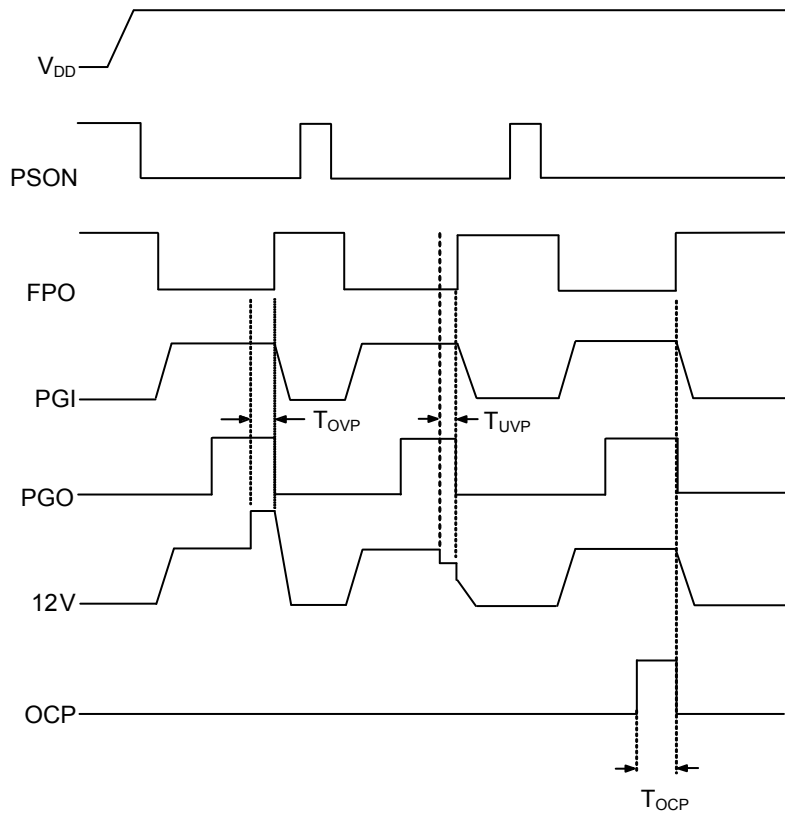

UTC assumes no responsibility for equipment failures that result from using products at values that exceed, even momentarily, rated values (such as maximum ratings, operating condition ranges, or other parameters) listed in products specifications of any and all UTC products described or contained herein. UTC products are not designed for use in life support appliances, devices or systems where malfunction of these products can be reasonably expected to result in personal injury. Reproduction in whole or in part is prohibited without the prior written consent of the copyright owner. The information presented in this document does not form part of any quotation or contract, is believed to be accurate and reliable and may be changed without notice.