



UPS601

LINEAR INTEGRATED CIRCUIT

HIGH PERFORMANCE CURRENT MODE POWER SWITCH

DESCRIPTION

The UTC **UPS601** is designed to provide several special enhancements to satisfy the needs, for example, Power-Saving mode for low standby power (<0.3W), Frequency Hopping , Constant Output Power Limiting , Slope Compensation ,Over Current Protection (OCP), Over Voltage Protection (OVP), Over Load Protection (OLP), Under Voltage Lock Out (UVLO), Short Circuit Protection (SCP) , Over Temperature Protection (OTP) etc. IC will be shutdown or can auto-restart in situations. .

FEATURES

- * Low startup current 22µA typ
- * Fixed switching frequency(Norm. is 68kHz)
- * Frequency hopping to reduce EMI Emission
- * Lower than 0.3W Standby Power Design
- * Linearly decreasing frequency to 26KHz during light load
- * Soft start
- * Internal Slope Compensation
- * Constant Power Limit all over AC Input Range
- * Gate Output Maximum Voltage Clamp(15V)
- * Max duty cycle 74%
- * Over temperature protection
- * Overload protection
- * Over voltage protection
- * Leading edge blanking
- * Pulse-By-Pulse Current Limit
- * Under Voltage Lock Out
- * Short Circuit Protection

ORDERING INFORMATION

Ordering Number		Package	Packing
Lead Free	Halogen Free	DIP-8	Tube
UPS601L-D08-T	UPS601G-D08-T		

<p>UPS601L-D08-T</p> <p>(1) Packing Type (2) Package Type (3) Lead Free</p>	<p>(1) T: Tube (2) D08: DIP-8 (3) G: Halogen Free, L: Lead Free</p>
---	---

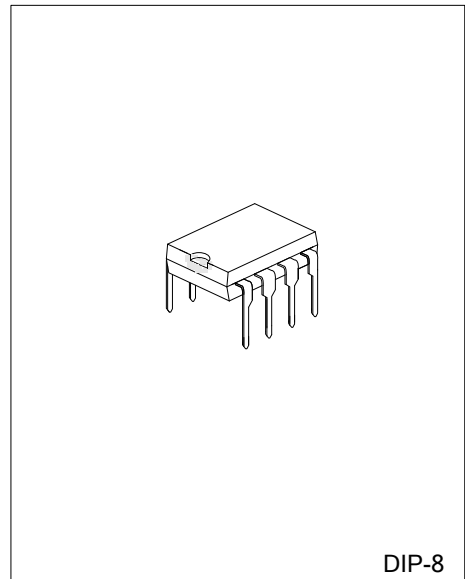

■ PIN CONFIGURATION

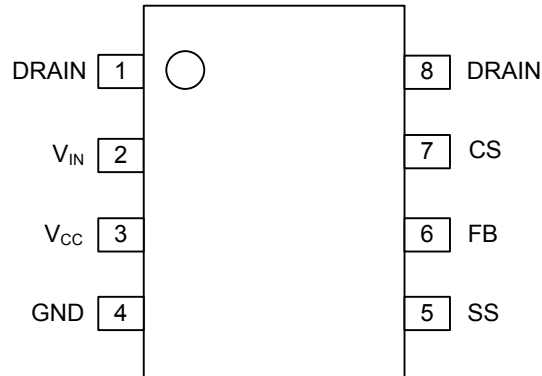

■ PIN DESCRIPTION

PIN NO.	SYMBOL	DESCRIPTION
1	DRAIN	Power MOSFET drain
2	V _{IN}	For startup and constant power limit, this pin is pulled to the line input via resistor
3	V _{CC}	Supply voltage
4	GND	Ground
5	SS	Soft-start
6	FB	Feedback
7	CS	Controller current sense input
8	DRAIN	Power MOSFET drain

■ BLOCK DIAGRAM

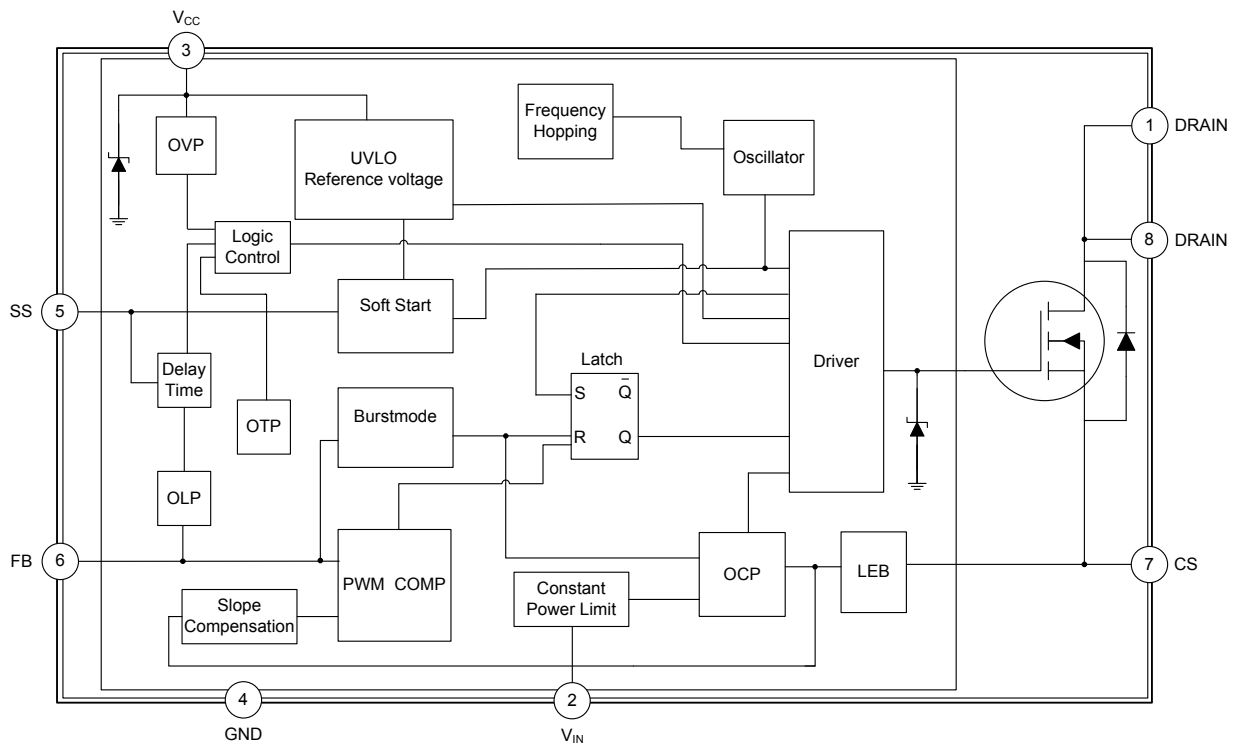

- Notes:
- OLP (Over Load Protection)
 - OVP (Over Voltage Protection)
 - OTP (Over Temperature Protection)
 - OCP (Over Current Protection)
 - UVLO (Under Voltage Latch-Out)
 - LEB (Led Edge Blanking)
 - SS (Soft Start)

■ ABSOLUTE MAXIMUM RATINGS (Ta=25°C, unless otherwise specified)

PARAMETER	SYMBOL	RATINGS	UNIT
Supply Voltage	V _{CC}	30	V
Input Voltage to Vin Pin	V _{in}	30	V
Input Voltage to FB Pin	V _{FB}	-0.3 ~ 6.2	V
Input Voltage to CS Pin	V _{CS}	-0.3 ~ 2.8	V
Junction Temperature	T _J	+150	°C
Operating Temperature	T _{OPR}	-40 ~ +125	°C
Storage Temperature	T _{STG}	-50 ~ +150	°C

Note: Absolute maximum ratings are those values beyond which the device could be permanently damaged. Absolute maximum ratings are stress ratings only and functional device operation is not implied.

■ RECOMMENDED OPERATING CONDITIONS

PARAMETER	SYMBOL	RATINGS	UNIT
Supply Voltage	V _{CC}	8.6 ~ 22	V

■ ELECTRICAL CHARACTERISTICS (Ta=25°C, V_{CC}=15V, unless otherwise specified)

PARAMETER	SYMBOL	TEST CONDITIONS	MIN	TYP	MAX	UNIT
SUPPLY SECTION						
Start Up Current	I _{STR}	V _{CC} = V _{CC(ON)} -0.1V		22	45	μA
Supply Current with switch	I _{OFF}	V _{SS} = 0, I _{FB} = 0		7	9	mA
	I _{ON}	V _{SS} = 4.8V, I _{FB} = 0		7	9	mA
UNDER-VOLTAGE LOCKOUT SECTION						
Start Threshold Voltage	V _{THD(ON)}		13.5	14.2	15	V
Min. Operating Voltage	V _{CC(MIN)}		7.5	8.2	9	V
Hysteresis	V _{CC(HY)}			6		V
INTERNAL VOLTAGE REFERENCE						
Reference Voltage	V _{REF}	measured at pin V _{FB}	6.3	6.5	6.7	V
CONTROL SECTION						
V _{FB} Operating Level	V _{MIN}		0.5			V
	V _{MAX}				4.4	
Burst-Mode Out FB Voltage	V _{FB(OUT)}	V _{CS} = 0		1.7		V
Reduce-Frequency end FB Voltage	V _{FB(END)}	V _{CS} = 0		1.6		V
Burst-Mode Enter FB Voltage	V _{FB(IN)}	V _{CS} = 0		1.5		V
Switch Frequency	F _(SW)	V _{FB} = 4V	61	68	75	kHz
		Before enter burst mode	20		40	
Duty Cycle	D _{MAX}	V _{FB} =4.4V, V _{CS} =0	68	74	80	%
	D _{MIN}	V _{FB} <0.5V	0			%
Frequency Hopping	F _{J(SW)}		±1.5	±3	±4.5	kHz
Frequency Variation VS V _{CC} Deviation	F _{DV}	V _{CC} =10 to 20V			5	%
Frequency Variation VS Temperature Deviation	F _{DT}	T=-40 to 105°C			5	%
Feedback Resistor	R _{FB}	V _{FB} =0V	16	21	26	kΩ
Soft-Start Time	T _{SS}	C _{SS} =0.47μF	9.9	11.2	12.6	ms
PROTECTION SECTION						
OVP threshold	V _{OVP1}	V _{SS} <3.5V, V _{FB} >5V		19		V
	V _{OVP2}	V _{SS} =4.8V, V _{FB} =3V		28		V
OLP threshold	V _{FB(OLP)}	V _{CS} =0, SS OPEN	4.7	4.9	5.1	V
Delay Time Of OLP	T _{D-OLP}	C _{SS} =0.47μF	55	62	70	ms
OTP threshold	T _(THR)		120	135	150	°C
OVP Disable threshold	V _{SS(DEACT)}	V _{FB} >5V, V _{CC} = 22V	3.9	4.1	4.3	V
OLP Enable threshold	V _{SS(ACT)}	V _{FB} >5V	5.1	5.4	5.7	V

■ ELECTRICAL CHARACTERISTICS(Cont.)

PARAMETER	SYMBOL	TEST CONDITIONS	MIN	TYP	MAX	UNIT
CURRENT LIMITING SECTION						
Peak Current Limitation	V_{CS}	$V_{FB}=4.4V$		0.86	1	V
Threshold Voltage For $I_{VIN}=60\mu A$	$V_{SENSE-L}$	$I_{VIN}=60\mu A$		0.77		V
POWER MOS-TRANSISTOR SECTION						
Drain-Source Breakdown Voltage	V_{DSS}	$V_{GS}=0V, I_D=250\mu A$	600			V
Turn-on voltage between gate and source	V_{TH}	$V_{DS}=V_{GS}, I_D=250\mu A$	2		4	V
Drain-Source Diode Continuous Source Current	I_S				1.2	A
Static Drain-Source On-State Resistance	$R_{DS(ON)}$	$V_{GS}=10V, I_D=0.6A$		9.3	11.5	Ω
Rise Time	t_R	$V_{DD}=300V, I_D=1.2A$		25	60	ns
Fall Time	t_F	$R_G=50\Omega$ (Note 1,2)		25	60	ns

Notes: 1. Pulse Test: Pulse width $\leq 300\mu s$, Duty cycle $\leq 2\%$

2. Essentially independent of operating temperature

FUNCTIONAL DESCRIPTION

The internal reference voltages and bias circuit work at $V_{CC} > V_{THD(ON)}$, and shutdown at $V_{CC} < V_{CC(MIN)}$.

(1) Soft-Start

When every IC power on, driver output duty cycle will be decided by voltage V_{SS} on soft-start capacitor and V_{CS} on current sense resistor at beginning. After V_{SS} reach 4.2V, the whole soft-start phase end, and driver duty cycle depend on V_{FB} and V_{CS} . The relation among V_{SS} , V_{FB} and V_{OUT} as followed FIG.3.

Furthermore, soft-start phase should end before V_{CC} reach $V_{CC(MIN)}$ during V_{CC} power on. Otherwise, if soft-start phase remain not end before V_{CC} reach $V_{CC(MIN)}$ during V_{CC} power on, IC will enter auto-restart phase and not set up V_{OUT} . So the value of C_{SS} should be between 0.1 μ F and 4.7 μ F.

Finally soft-start also set OVP1 active phase. OVP1 active phase between 0 and $V_{SS(DEACT)}$, OVP1 will not be sensed after V_{SS} reach $V_{SS(DEACT)}$. The Soft-start phase T_{SS} : $T_{SS} = 23.8 \times C_{SS}$ (ms) (Example: $C_{SS} = 0.47\mu$ F, then $T_{SS} = 23.8 \times 0.47 = 11.2$ ms).

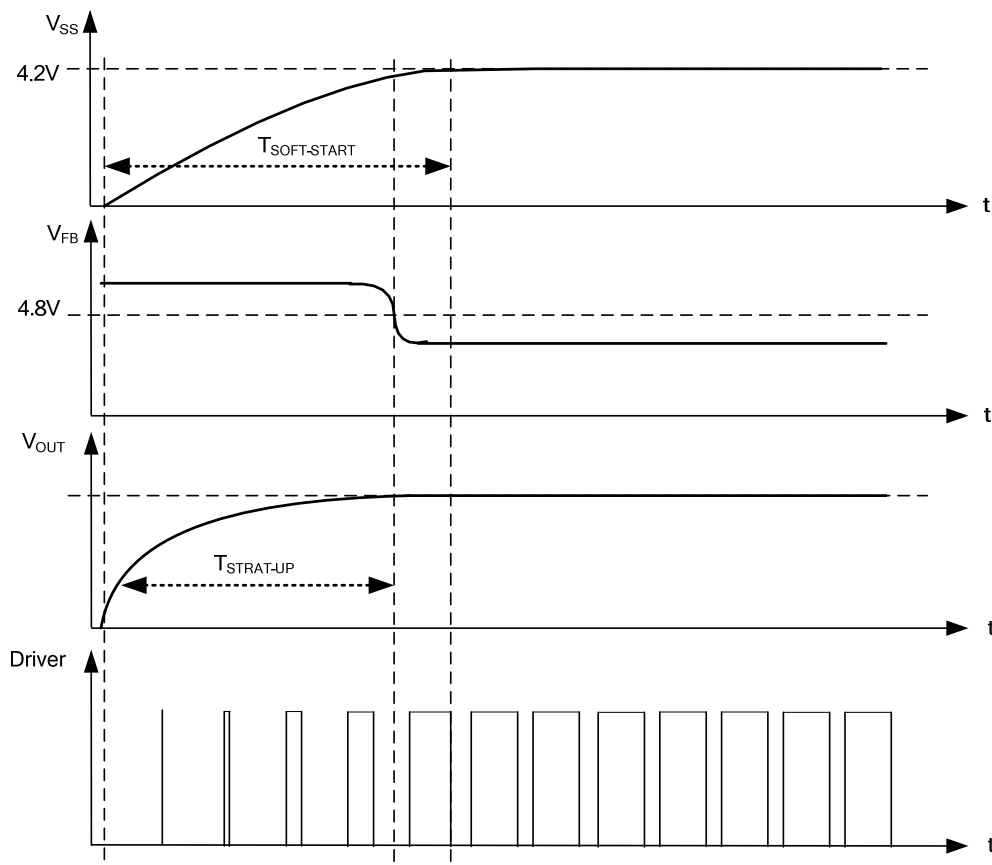

FIG.3 Soft-start phase

■ FUNCTIONAL DESCRIPTION(Cont.)

(2) Switch Frequency Set

The maximum switch frequency is set to 68kHz. Switch frequency is modulated by output power P_{OUT} during IC operating. At no load or light load condition, most of the power dissipation in a switching mode power supply is from switching loss on the MOSFET transistor, the core loss of the transformer and the loss on the subber circuit. The magnitude of power loss is in proportion to the number of switching events within a fixed period of time. So lower switch frequency at lower load, which more and more improve IC's efficiency at light load. At from no load to light load condition, The IC will operate at from Burst mode to Reducing Frequency Mode. The relation curve between f_{sw} and $P_{OUT}/P_{OUT(MAX)}$ as followed FIG.4.

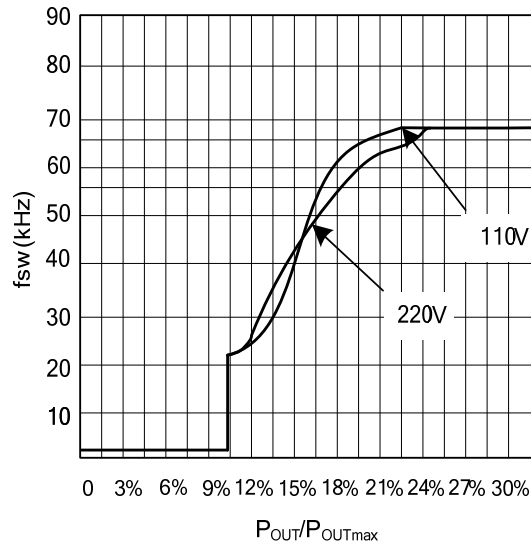

FIG.4 The relation curve between f_{sw} and relative output power $P_{OUT}/ P_{OUT (MAX)}$

(3) Internal Synchronized Slope Compensation

Built-in slope compensation circuit adds voltage ramp onto the current sense input voltage for PWM generation, this greatly improves the close loop stability at CCM and prevents the sub-harmonic oscillation and thus reduces the output ripple voltage.

(4) Frequency Hopping For EMI Improvement

The Frequency hopping is implemented in the IC; there are two oscillators built-in the IC. The first oscillator is to set the normal switching frequency; the switching frequency is modulated with a period signal generated by the 2nd oscillator. The relation between the first oscillator and the 2nd oscillator as followed FIG.5. So the tone energy is evenly spread out, the spread spectrum minimizes the conduction band EMI and therefore eases the system design in meeting stringent EMI requirement.

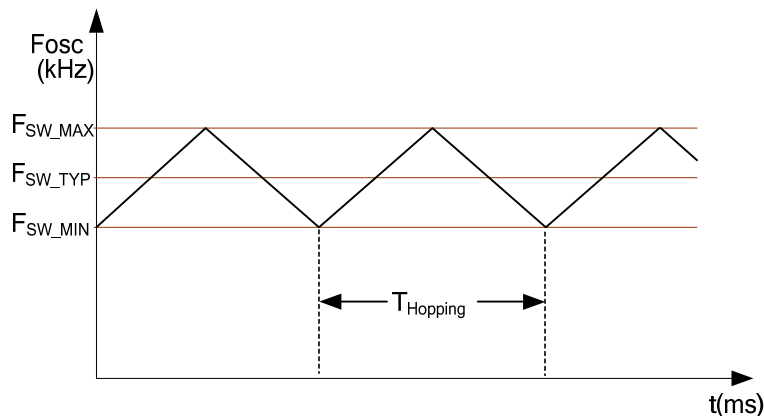

FIG.5 Frequency Hopping

■ FUNCTIONAL DESCRIPTION(Cont.)

(5) Constant Output Power Limit

When the SENSE voltage, across the sense resistor R_S , reaches the threshold voltage, around 0.8V, the output GATE drive will be turned off after a small propagation delay t_D . This propagation delay will introduce an additional current proportional to $t_D \times V_{IN}/L_p$. Since the propagation delay is nearly constant regardless of the input line voltage V_{IN} . Higher input line voltage will result in a larger additional current and hence the output power limit is also higher than that under low input line voltage. To compensate this variation for wide AC input range, the threshold voltage is adjusted by the V_{IN} current. Since V_{IN} pin is connected to the rectified input line voltage through a resistor R_{VIN} , a higher line voltage will generate higher V_{IN} current into the V_{IN} pin. The threshold voltage is decreased if the V_{IN} current is increased. Smaller threshold voltage, forces the output GATE drive to terminate earlier, thus reduce the total PWM turn-on time and make the output power equal to that of low line input. This proprietary internal compensation ensures a constant output power limit for wide AC input voltage from 90VAC to 264VAC.

(6) Protection section

The IC takes on more protection functions such as OLP, OVP and OTP etc. In case of those failure modes for continual blanking time, the driver is shut down. At the same time, IC enters auto-restart, V_{CC} power on and driver is reset after V_{CC} power on again.

OLP

After soft-start phase end, IC will shutdown driver if over load state occurs for continual T_{D-OLP} . OLP function will not inactive during soft-start phase. OLP case as followed FIG. 6. The test circuit as followed FIG.8. $T_{D-OLP} = 5.53 \times T_{SS}$.

OVP

There are two kinds of OVP circuits, the first OVP function are enabled only when $V_{SS} < V_{SS(DEACT)}$ & $V_{FB} > V_{FB(OLP)}$ during soft-start phase. During above condition, driver will be shutdown if over voltage state occurs ($V_{CC} > V_{OVP1}$) for continual a blanking time. The first OVP function will not inactive after soft-start phase. The second OVP will shutdown the switching of the power MOSFET whenever $V_{CC} > V_{OVP2}$. The first OVP case as followed FIG.7. The test circuit as followed FIG.9.

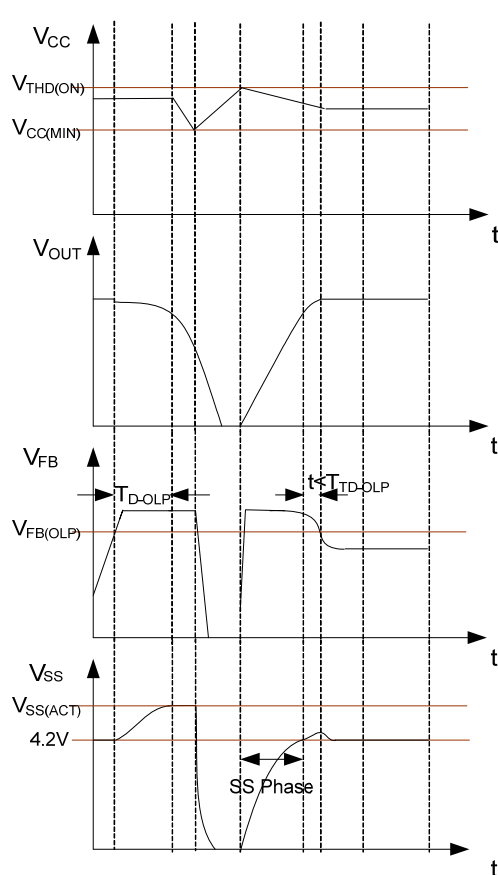

FIG.6 OLP case

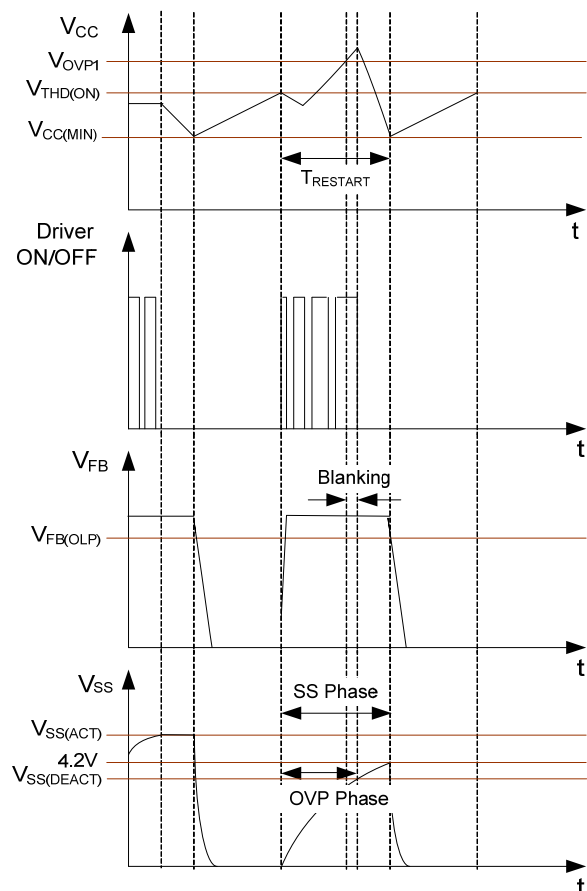

FIG.7 OVP case

■ FUNCTIONAL DESCRIPTION(Cont.)

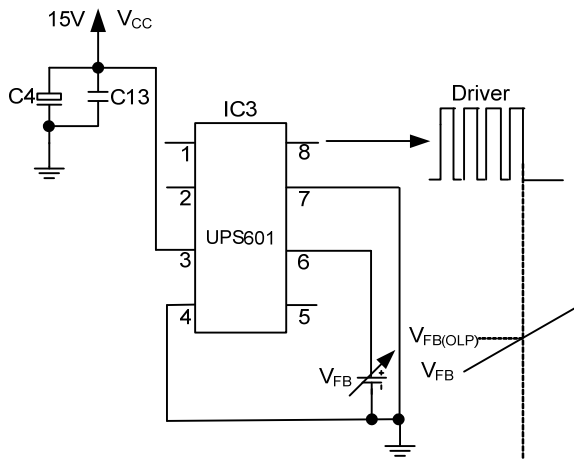

FIG.8 OLP test circuit

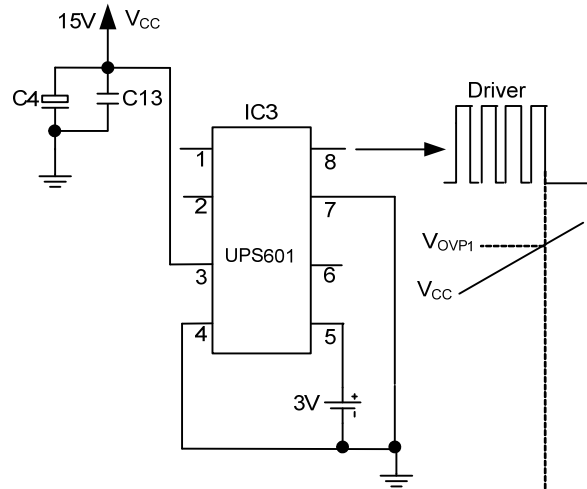

FIG.9 OVP test circuit

OTP

OTP will shut down driver when junction temperature $T_J > T_{(THR)}$ for continual a blanking time.

(7) Driver Output Section

The driver-stage drives the gate of the MOSFET and is optimized to minimize EMI and to provide high circuit efficiency. This is done by reducing the switch on slope when reaching the MOSFET threshold. This is achieved by a slope control of the rising edge at the driver's output. The output driver is clamped by an internal 15V Zener diode in order to protect power MOSFET transistors against undesirable gate over voltage.

(8) Inside power switch MOS transistor

Specific power MOS transistor parameter is as "POWER MOS TRANSISTOR SECTION" in electrical characteristics table.

■ TYPICAL APPLICATION CIRCUIT

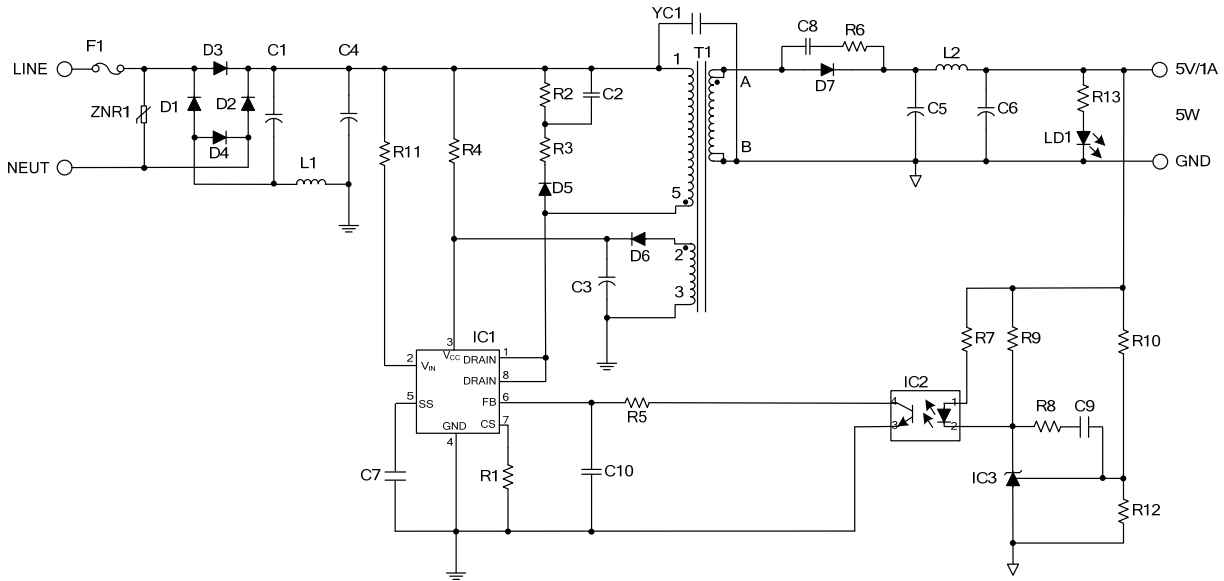
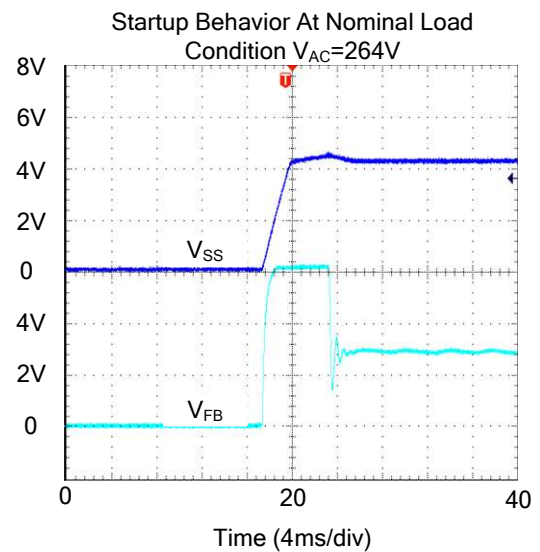
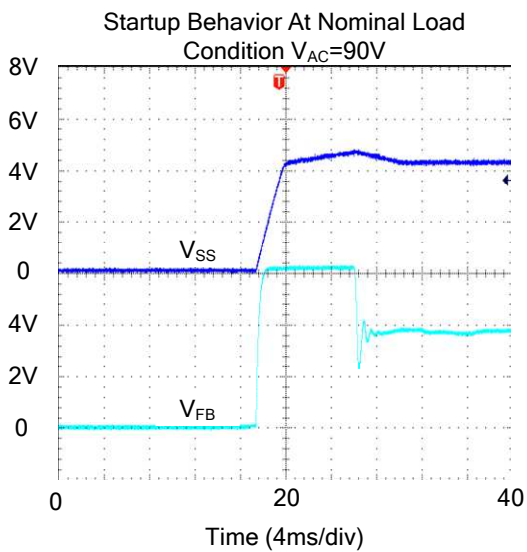
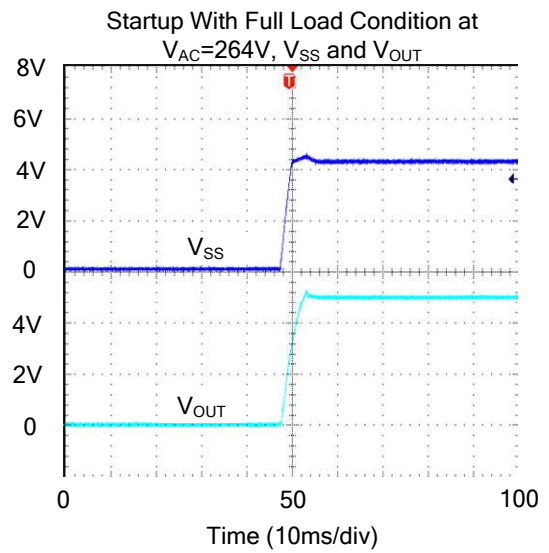
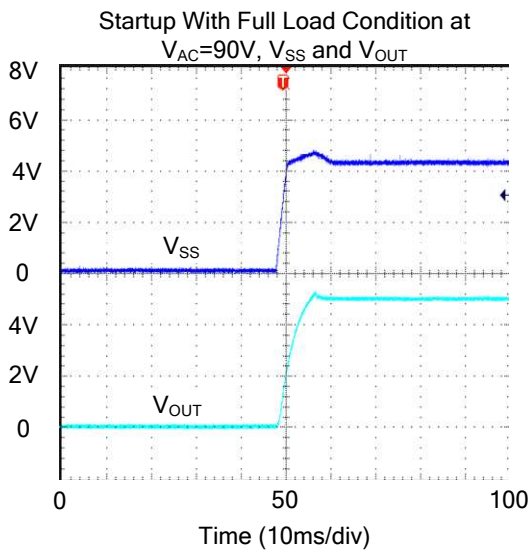
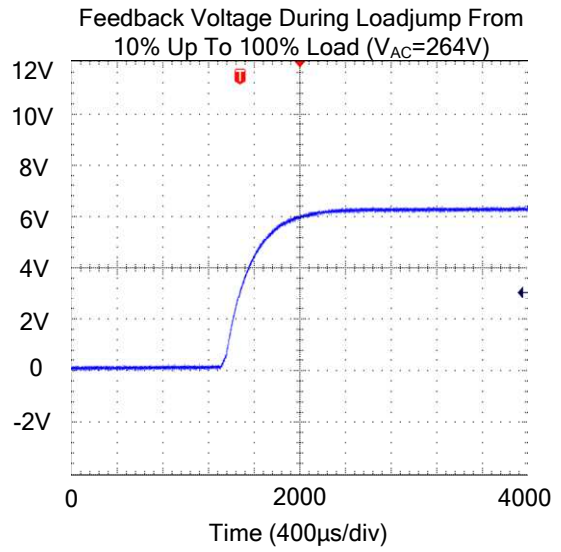
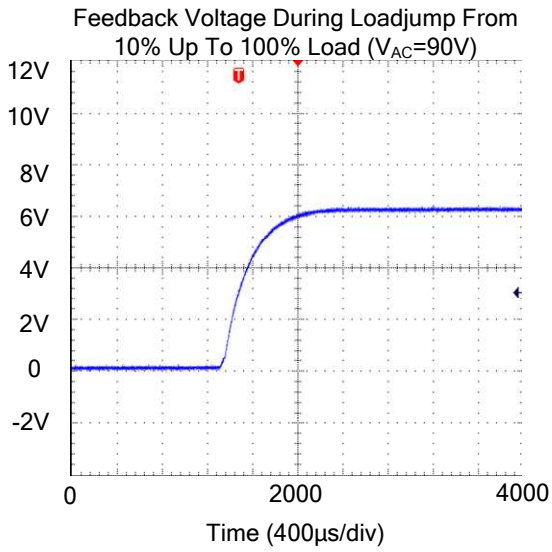

FIG.10 UPS601 Typical Application Circuit

Table1. Components reference description for UPS601 application circuit

DESIGNATOR	PART TYPE	DESIGNATOR	PART TYPE	DESIGNATOR	PART TYPE
C1	6.8 μ F	R1	3.4 Ω	D1	1N4007
C2	0.0022 μ F	R2	100K Ω	D2	1N4007
C3	22 μ F	R3	100 Ω	D3	1N4007
C4	6.8 μ F	R4	1M Ω	D4	1N4007
C5	1000 μ F	R5	0 Ω	D5	FR107
C6	100 μ F	R6	15 Ω	D6	RS1D
C7	0.1 μ F	R7	510 Ω	D7	SB340
C8	0.001 μ F	R8	4.7K Ω	IC1	UPS601
C9	0.1 μ F	R9	1.8K Ω	IC2	PC-817
C10	0.01 μ F	R10	5.11K Ω	IC3	TL431NSL
		R11	1.5~4M Ω	YC1	0.001 μ F
		R12	4.99K Ω	T1	EE-16
		R13	1K Ω	L1	1mH
				L2	2 μ H
				LD1	LED
				F1	1A/250V
				ZNR1	07D471K

■ TYPICAL CHARACTERISTICS



■ TYPICAL CHARACTERISTICS(Cont.)

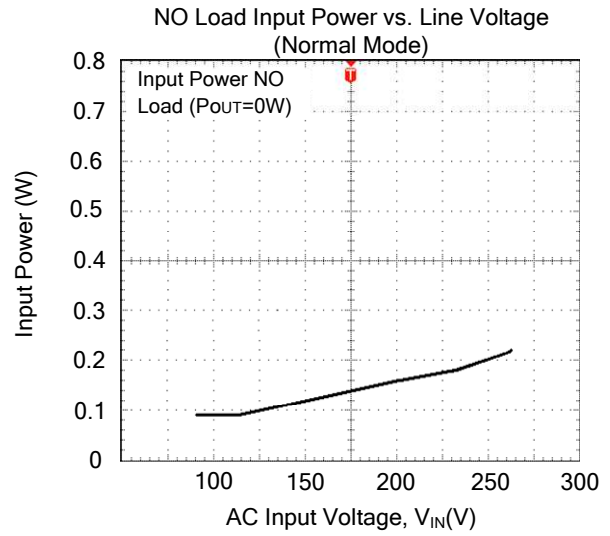
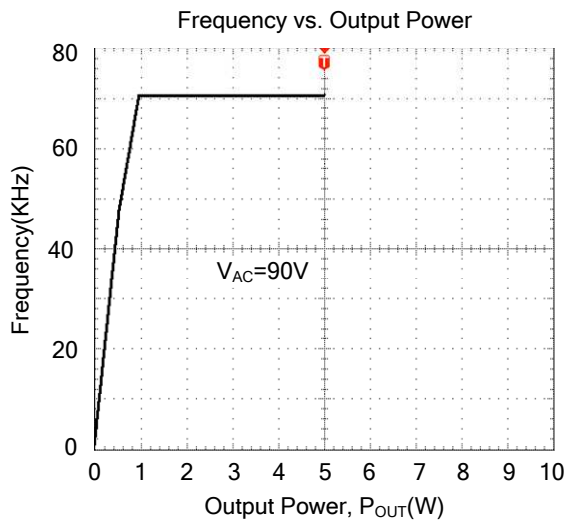

UTC assumes no responsibility for equipment failures that result from using products at values that exceed, even momentarily, rated values (such as maximum ratings, operating condition ranges, or other parameters) listed in products specifications of any and all UTC products described or contained herein. UTC products are not designed for use in life support appliances, devices or systems where malfunction of these products can be reasonably expected to result in personal injury. Reproduction in whole or in part is prohibited without the prior written consent of the copyright owner. The information presented in this document does not form part of any quotation or contract, is believed to be accurate and reliable and may be changed without notice.