



# UC3848

## LINEAR INTEGRATED CIRCUIT

### HIGH PERFORMANCE CURRENT MODE CONTROLLERS

#### DESCRIPTION

The UTC **UC3848** is designed to provide several special enhancements to satisfy the needs, for example, Power-Saving mode for low standby power (< 0.3W), Frequency Hopping , Constant Output Power Limiting , Slope Compensation ,Over Current Protection (OCP), Over Voltage Protection (OVP), Over Load Protection (OLP), Under Voltage Lock Out (UVLO), Short Circuit Protection (SCP) , Over Temperature Protection (OTP) etc. IC will be shutdown or can auto-restart in situations.

#### FEATURES

- \* Low Startup Current (about 22μA)
- \* Fixed Switching Frequency(Norm. is 68KHz)
- \* Frequency Hopping for Improved EMI Performance.
- \* Lower than 0.3W Standby Power Design
- \* Linearly Decreasing Frequency to 26KHz During Light Load
- \* Soft Start
- \* Internal Slope Compensation
- \* Constant Power Limiting for Universal AC input Range
- \* Gate Output Maximum Voltage Clamp(15V)
- \* Max Duty Cycle 74%
- \* Over Temperature Protection
- \* Overload Protection
- \* Over Voltage Protection
- \* Leading Edge Blanking
- \* Cycle-by-Cycle Current Limiting
- \* Under Voltage Lock Out
- \* Short Circuit Protection

#### ORDERING INFORMATION

Ordering Number		Package	Packing
Lead Free	Halogen Free		
UC3848L-D08-T	UC3848G-D08-T	DIP-8	Tube
UC3848L-S08-R	UC3848G-S08-R	SOP-8	Tape Reel

<p>UC3848L-D08-T</p> <p>(1)Packing Type (2)Package Type (3)Lead Free</p>	<p>(1) R: Tape Reel, T: Tube (2) D08: DIP-8, S08: SOP-8 (3) L: Lead Free, G: Halogen Free</p>
--	---

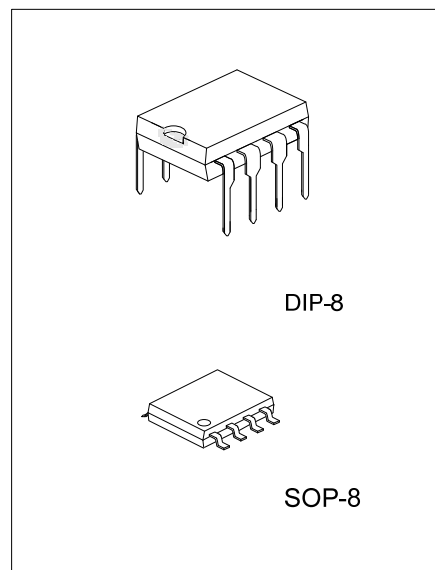

### ■ PIN CONFIGURATION

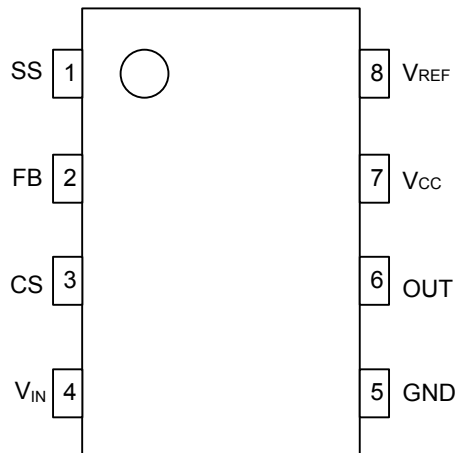

### ■ PIN DESCRIPTION

PIN NO.	SYMBOL	FUNCTION
1	SS	Soft-start
2	FB	Feedback
3	CS	Controller current sense input
4	$V_{IN}$	Connected $R_{VIN}$ to line voltage compensating $V_{CSTH}$ , and providing constant output power limiting for universal AC input Range
5	GND	Ground
6	OUT	Output to the gate of external power MOS
7	$V_{CC}$	Supply voltage
8	$V_{REF}$	Inter Reference Voltage

## ■ BLOCK DIAGRAM

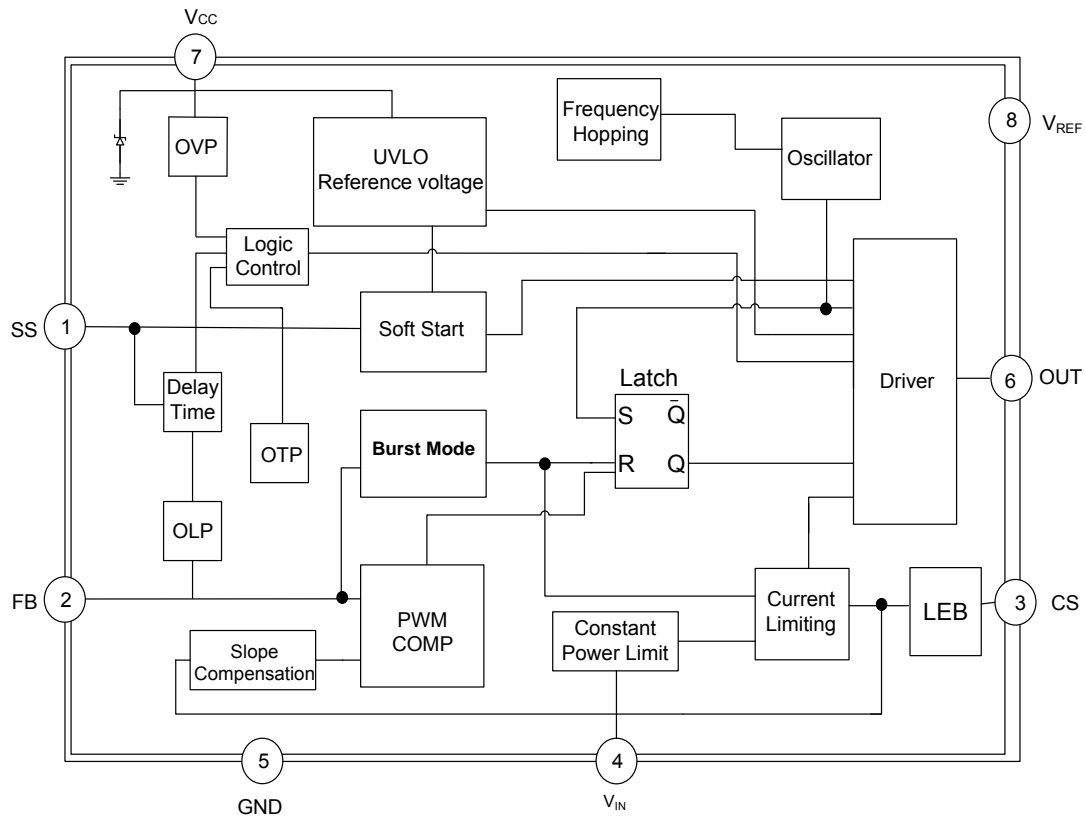

### ■ ABSOLUTE MAXIMUM RATINGS (Ta=25°C, V<sub>CC</sub>=15V, unless otherwise specified)

PARAMETER	SYMBOL	RATINGS	UNIT
Supply Voltage	V <sub>CC</sub>	30	V
Input Voltage to V <sub>IN</sub> Pin	V <sub>IN</sub>	30	V
Input Voltage to FB Pin	V <sub>FB</sub>	-0.3 ~ 6.2	V
Input Voltage to CS Pin	V <sub>CS</sub>	-0.3 ~ 2.8	V
Junction Temperature	T <sub>J</sub>	+150	°C
Operating Temperature	T <sub>OPR</sub>	-40 ~ +125	°C
Storage Temperature	T <sub>STG</sub>	-50 ~ +150	°C

Note: Absolute maximum ratings are those values beyond which the device could be permanently damaged.

Absolute maximum ratings are stress ratings only and functional device operation is not implied.

### ■ RECOMMENDED OPERATING CONDITIONS

PARAMETER	SYMBOL	RATINGS	UNIT
Supply Voltage	V <sub>CC</sub>	8.2 ~ 22	V

### ■ ELECTRICAL CHARACTERISTICS (Ta=25°C, V<sub>CC</sub>=15V, unless otherwise specified)

PARAMETER	SYMBOL	TEST CONDITIONS	MIN	TYP	MAX	UNIT
<b>SUPPLY SECTION</b>						
Start Up Current	I <sub>STR</sub>	V <sub>CC</sub> =V <sub>THD(ON)</sub> -0.1V		22	45	μA
Supply Current with switch	OFF	V <sub>SS</sub> = 0, I <sub>FB</sub> = 0		7	9	mA
	ON	V <sub>SS</sub> = 5V, I <sub>FB</sub> = 0		7	9	mA
<b>UNDER-VOLTAGE LOCKOUT SECTION</b>						
Start Threshold Voltage	V <sub>THD(ON)</sub>		13.5	14.2	15	V
Min. Operating Voltage	V <sub>CC(MIN)</sub>		7.5	8.2	9	V
Hysteresis	V <sub>CC(HY)</sub>			6		V
<b>INTERNAL VOLTAGE REFERENCE</b>						
Reference Voltage	V <sub>REF</sub>	Measured at pin V <sub>REF</sub>	6.3	6.5	6.7	V
<b>CONTROL SECTION</b>						
V <sub>FB</sub> Operating Level	V <sub>MIN</sub>		0.5			V
	V <sub>MAX</sub>				4.4	V
Burst-Mode Enter FB Voltage	V <sub>FB-IN</sub>	V <sub>CS</sub> =0		1.5		V
Reduce-Frequency end FB Voltage	V <sub>FB-END</sub>	V <sub>CS</sub> =0		1.6		V
Burst-Mode Out FB Voltage	V <sub>FB-out</sub>	V <sub>CS</sub> =0		1.7		V
Switch Frequency	F <sub>(SW)</sub>	V <sub>FB</sub> = 4V	61	68	75	kHz
		Before enter burst mode	20		40	
Duty Cycle	D <sub>MAX</sub>	V <sub>FB</sub> =4.4V, V <sub>CS</sub> =0	68	74	80	%
	D <sub>MIN</sub>	V <sub>FB</sub> < 0.5V	0			%
Feedback Resistor	R <sub>FB</sub>	V <sub>FB</sub> =0V	16	21	26	kΩ
Soft-Start Time	T <sub>SS</sub>	C <sub>SS</sub> =0.47uF	9.9	11.2	12.6	ms
<b>PROTECTION SECTION</b>						
OVP threshold	V <sub>OVP1</sub>	V <sub>SS</sub> < 3.5V, V <sub>FB</sub> > 5V		19		V
	V <sub>OVP1</sub>	V <sub>SS</sub> =4.8V, V <sub>FB</sub> =3V		28		
OVP threshold	V <sub>FB(OLP)</sub>	V <sub>CS</sub> > 0V, SS Open	4.7	4.9	5.1	V
Delay Time Of OLP	T <sub>D-OLP</sub>	C <sub>SS</sub> =0.47uF	55	62	70	ms
OTP threshold	T <sub>(THR)</sub>		120	135	150	°C
OVP Disable threshold	V <sub>SS(DEACT)</sub>	V <sub>FB</sub> > 5V, V <sub>CC</sub> =22V	3.9	4.1	4.3	V
OLP Enable threshold	V <sub>SS(ACT)</sub>	V <sub>FB</sub> > 5V	5.1	5.4	5.7	V
<b>CURRENT LIMITING SECTION</b>						
LEB	t <sub>LEB</sub>			220		ns
Peak Current Limitation	V <sub>CS</sub>	V <sub>FB</sub> =4.4V		0.86	1	V
Threshold Voltage For I <sub>VIN</sub> =60uA	V <sub>SENSE-L</sub>	I <sub>VIN</sub> =60uA		0.77		V
<b>DRIVER OUTPUT SECTION</b>						
Output Voltage Low State	V <sub>OL</sub>	I <sub>SOURCE</sub> = 200 mA			2.5	V
Output Voltage High State	V <sub>OH</sub>	I <sub>SINK</sub> = 200 mA	12.2			V
Output Voltage Rise Time	t <sub>R</sub>	C <sub>L</sub> = 1.0 nF		200	300	ns
Output Voltage Fall Time	t <sub>F</sub>	C <sub>L</sub> = 1.0 nF		50	90	ns

## FUNCTIONAL DESCRIPTION

The internal reference voltages and bias circuit work at  $V_{CC} > V_{THD(ON)}$ , and shutdown at  $V_{CC} < V_{CC(MIN)}$ .

### (1) Soft-Start

When every IC power on, driver output duty cycle will be decided by voltage  $V_{SS}$  on soft-start capacitor and  $V_{CS}$  on current sense resistor at beginning. After  $V_{SS}$  reach 4.2V, the whole soft-start phase end, and driver duty cycle depend on  $V_{FB}$  and  $V_{CS}$ . The relation among  $V_{SS}$ ,  $V_{FB}$  and  $V_{OUT}$  as followed FIG.3.

Furthermore, soft-start phase should end before  $V_{CC}$  reach  $V_{CC(MIN)}$  during  $V_{CC}$  power on. Otherwise, if soft-start phase remain not end before  $V_{CC}$  reach  $V_{CC(MIN)}$  during  $V_{CC}$  power on, IC will enter auto-restart phase and not set up  $V_{OUT}$ . So the value of  $C_{SS}$  should be between 0.1 $\mu$ F and 4.7 $\mu$ F.

Finally soft-start also set OVP1 active phase. OVP1 active phase between 0 and  $V_{SS(DEACT)}$ , OVP1 will not be sensed after  $V_{SS}$  reach  $V_{SS(DEACT)}$ . The Soft-start phase  $T_{SS}$ :  $T_{SS} = 23.8 \times C_{SS}$  (ms) (Example:  $C_{SS} = 0.47\mu$ F, then  $T_{SS} = 23.8 \times 0.47 = 11.2$ ms).

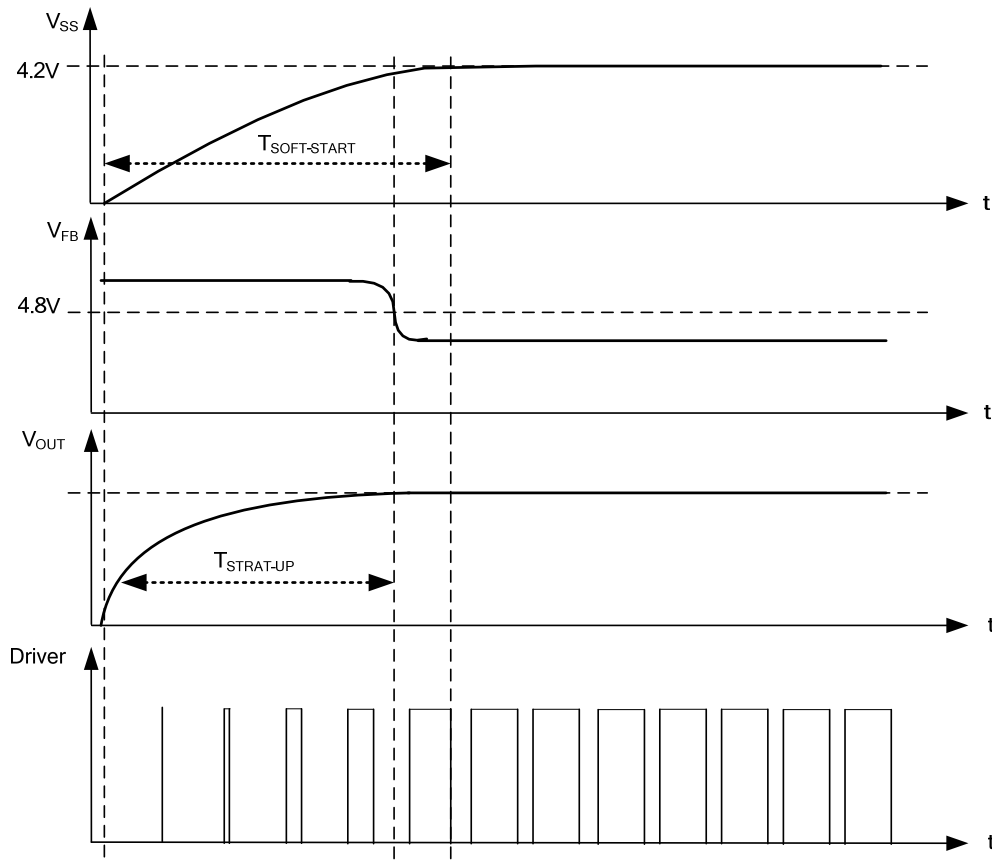

FIG.3 Soft-start phase

## ■ FUNCTIONAL DESCRIPTION(Cont.)

### (2) Switch Frequency Set

The maximum switch frequency is set to 68kHz. Switch frequency is modulated by output power  $P_{OUT}$  during IC operating. At no load or light load condition, most of the power dissipation in a switching mode power supply is from switching loss on the MOSFET transistor, the core loss of the transformer and the loss on the subber circuit. The magnitude of power loss is in proportion to the number of switching events within a fixed period of time. So lower switch frequency at lower load, which more and more improve IC's efficiency at light load. At from no load to light load condition, The IC will operate at from Burst mode to Reducing Frequency Mode. The relation curve between  $f_{SW}$  and  $P_{OUT}/P_{OUT(MAX)}$  as followed FIG.4.

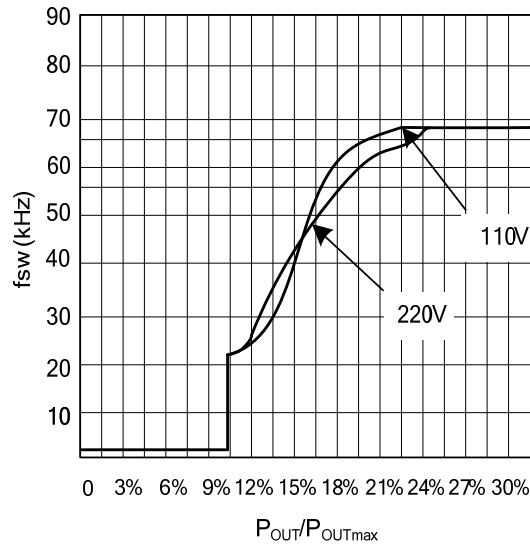

FIG.4 The relation curve between  $f_{SW}$  and relative output power  $P_{OUT}/ P_{OUT(MAX)}$

### (3) Internal Synchronized Slope Compensation

Built-in slope compensation circuit adds voltage ramp onto the current sense input voltage for PWM generation, this greatly improves the close loop stability at CCM and prevents the sub-harmonic oscillation and thus reduces the output ripple voltage.

## ■ FUNCTIONAL DESCRIPTION(Cont.)

### (4) Frequency Hopping For EMI Improvement

The Frequency hopping is implemented in the IC; there are two oscillators built-in the IC. The first oscillator is to set the normal switching frequency; the switching frequency is modulated with a period signal generated by the 2nd oscillator. The relation between the first oscillator and the 2nd oscillator as followed FIG.5. So the tone energy is evenly spread out, the spread spectrum minimizes the conduction band EMI and therefore eases the system design in meeting stringent EMI requirement.

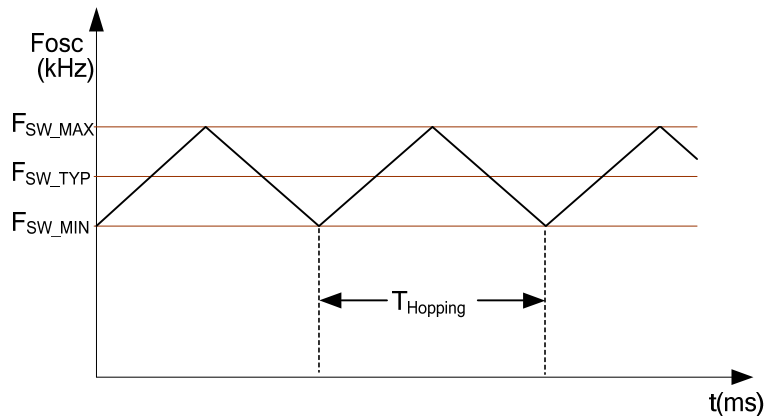

FIG.5 Frequency Hopping

### (5) Constant Output Power Limit

When the SENSE voltage, across the sense resistor  $R_S$ , reaches the threshold voltage, around 0.8V, the output GATE drive will be turned off after a small propagation delay  $t_D$ . This propagation delay will introduce an additional current proportional to  $t_D \times V_{IN} / L_p$ . Since the propagation delay is nearly constant regardless of the input line voltage  $V_{IN}$ . Higher input line voltage will result in a larger additional current and hence the output power limit is also higher than that under low input line voltage. To compensate this variation for wide AC input range, the threshold voltage is adjusted by the  $V_{IN}$  current. Since  $V_{IN}$  pin is connected to the rectified input line voltage through a resistor  $R_{VIN}$ , a higher line voltage will generate higher  $V_{IN}$  current into the  $V_{IN}$  pin. The threshold voltage is decreased if the  $V_{IN}$  current is increased. Smaller threshold voltage, forces the output GATE drive to terminate earlier, thus reduce the total PWM turn-on time and make the output power equal to that of low line input. This proprietary internal compensation ensures a constant output power limit for wide AC input voltage from 90VAC to 264VAC.

### (6) Driver Output Section

The driver-stage drives the gate of the MOSFET and is optimized to minimize EMI and to provide high circuit efficiency. This is done by reducing the switch on slope when reaching the MOSFET threshold. This is achieved by a slope control of the rising edge at the driver's output. The output driver is clamped by an internal 15V Zener diode in order to protect power MOSFET transistors against undesirable gate over voltage.

### (7) Protection section

The IC takes on more protection functions such as OLP, OVP and OTP etc. In case of those failure modes for continual blanking time, the driver is shut down. At the same time, IC enters auto-restart,  $V_{CC}$  power on and driver is reset after  $V_{CC}$  power on again.

#### OTP

OTP will shut down driver when junction temperature  $T_J > T_{(THR)}$  for continual a blanking time.

## FUNCTIONAL DESCRIPTION(Cont.)

### (7)Protection section (Cont.)

#### OLP

After soft-start phase end, IC will shutdown driver if over load state occurs for continual  $T_{D-OLP}$ . OLP function will not inactive during soft-start phase. OLP case as followed FIG. 6. The test circuit as followed FIG.8.  $T_{D-OLP}=5.53 \times T_{SS}$ .

#### OVP

There are two kinds of OVP circuits, the first OVP function are enabled only when  $V_{SS} < V_{SS(DEACT)}$  &  $V_{FB} > V_{FB(OLP)}$  during soft-start phase. During above condition, driver will be shutdown if over voltage state occurs ( $V_{CC} > V_{OVP1}$ ) for continual a blanking time. The first OVP function will not inactive after soft-start phase. The second OVP will shutdown the switching of the power MOSFET whenever  $V_{CC} > V_{OVP2}$ . The first OVP case as followed FIG.7. The test circuit as followed FIG. 9.

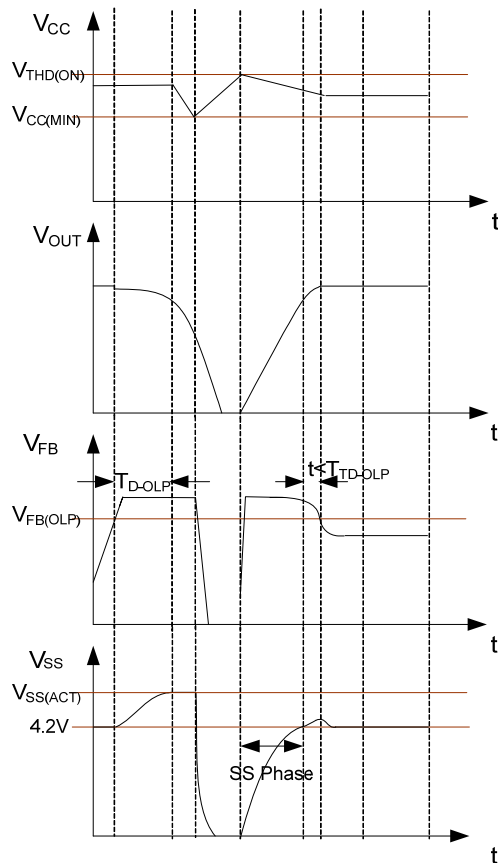

FIG.6 OLP case

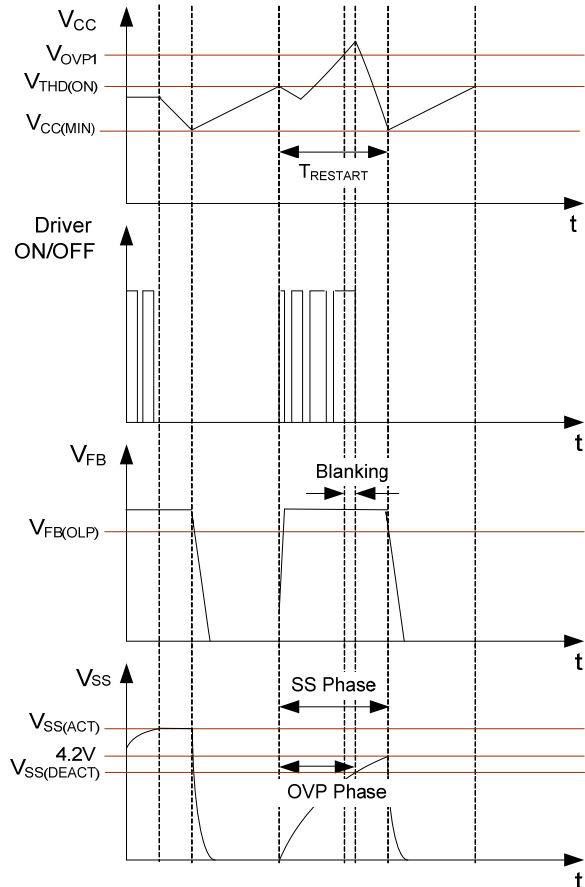

FIG.7 OVP case

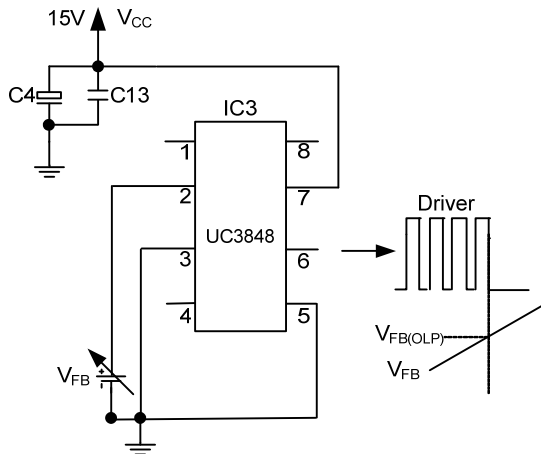

FIG.8 OLP test circuit

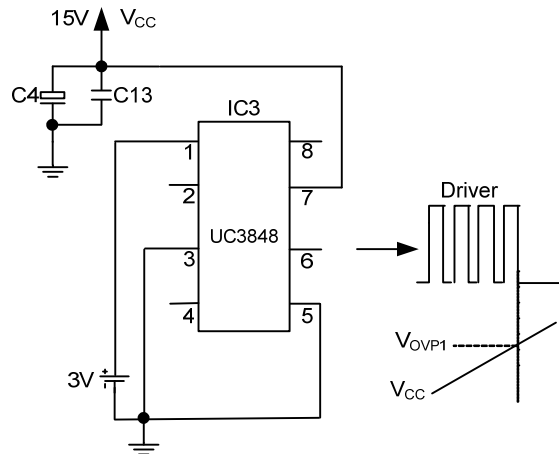
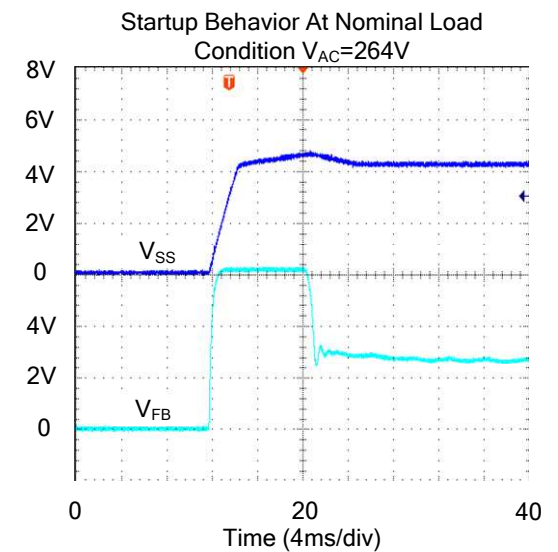
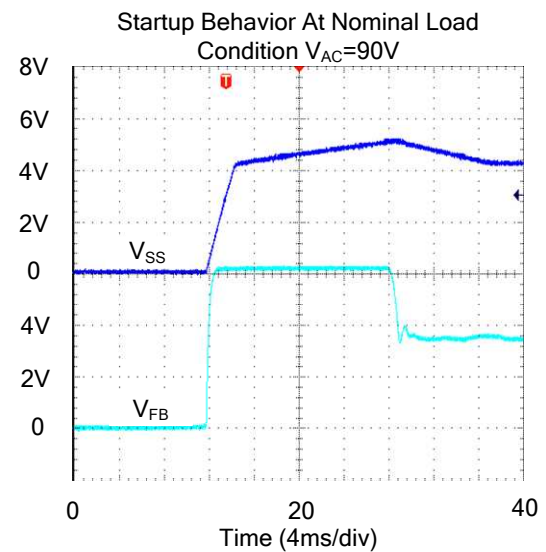
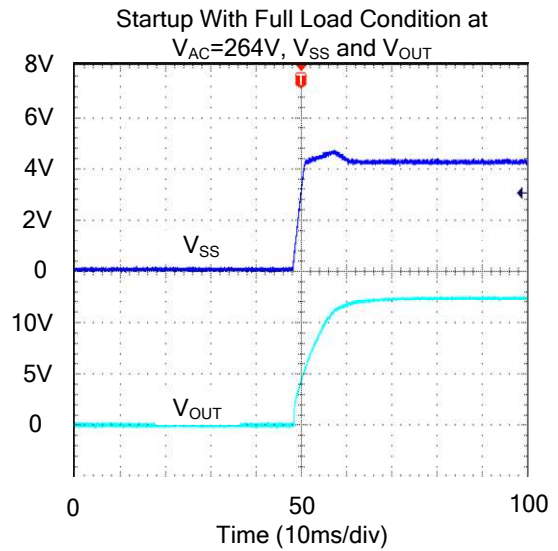
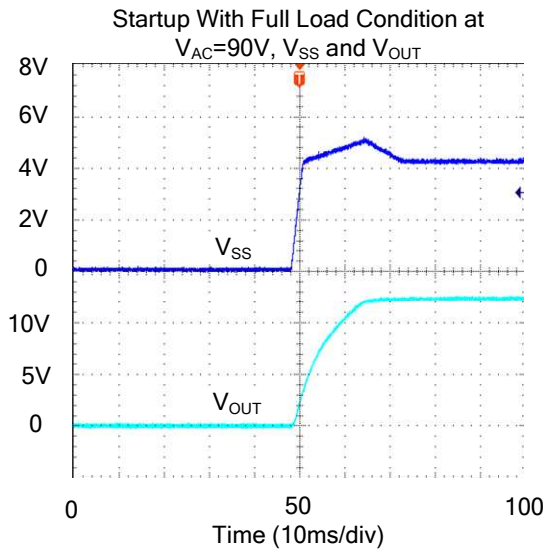
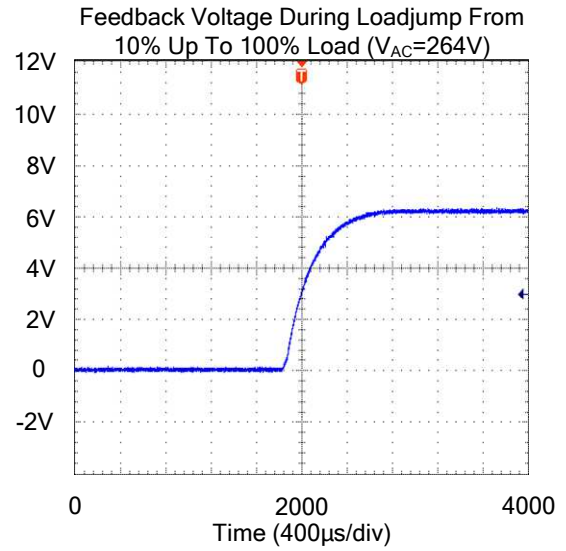
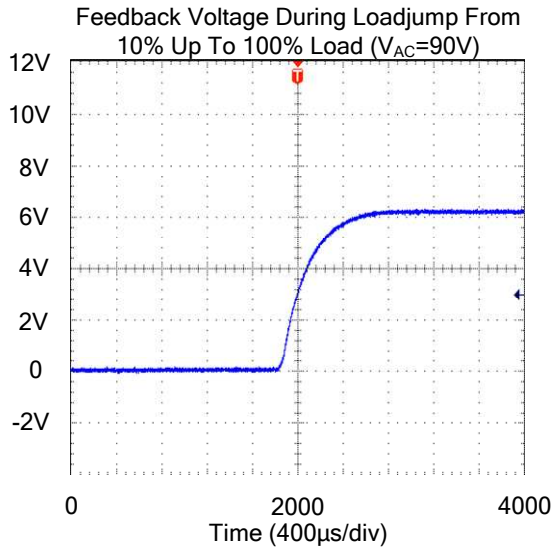

FIG.9 OVP test circuit



## TYPICAL CHARACTERISTICS



### ■ TYPICAL CHARACTERISTICS(Cont.)

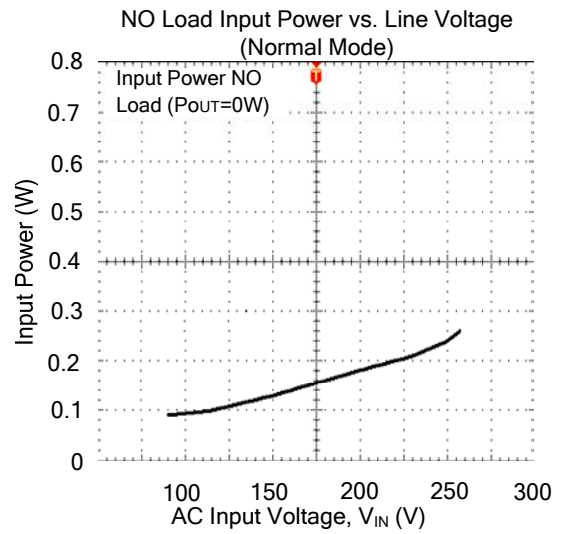
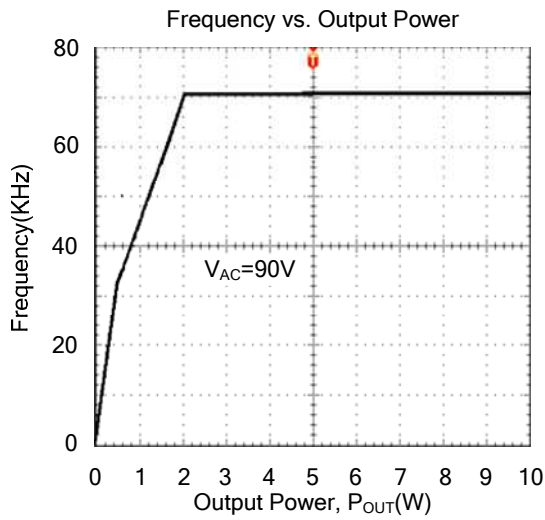

UTC assumes no responsibility for equipment failures that result from using products at values that exceed, even momentarily, rated values (such as maximum ratings, operating condition ranges, or other parameters) listed in products specifications of any and all UTC products described or contained herein. UTC products are not designed for use in life support appliances, devices or systems where malfunction of these products can be reasonably expected to result in personal injury. Reproduction in whole or in part is prohibited without the prior written consent of the copyright owner. The information presented in this document does not form part of any quotation or contract, is believed to be accurate and reliable and may be changed without notice.