



# TL494

## LINEAR INTEGRATED CIRCUIT

### VOLTAGE MODE PWM CONTROL CIRCUIT

#### DESCRIPTION

The UTC **TL494** incorporates all the functions required in the construction of a pulse-width modulation switching circuit. Designed primarily for switching power supply control or DC-DC converters, it offers the systems engineer the flexibility to tailor control circuitry to its own application.

#### FEATURES

- \* Complete PWM power control circuitry
- \* Uncommitted outputs for 200mA sink or source current
- \* Output control selects single ended or push pull operation
- \* Internal circuitry prohibits double pulses over total range
- \* Easy synchronization

#### ORDERING INFORMATION

| Ordering Number |              | Package  | Packing   |
|-----------------|--------------|----------|-----------|
| Lead Free       | Halogen Free |          |           |
| TL494L-D16-T    | TL494G-D16-T | DIP-16   | Tube      |
| TL494L-P16-R    | TL494G-P16-R | TSSOP-16 | Tape Reel |
| TL494L-P16-T    | TL494G-P16-T | TSSOP-16 | Tube      |
| TL494L-S16-R    | TL494G-S16-R | SOP-16   | Tape Reel |
| TL494L-S16-T    | TL494G-S16-T | SOP-16   | Tube      |

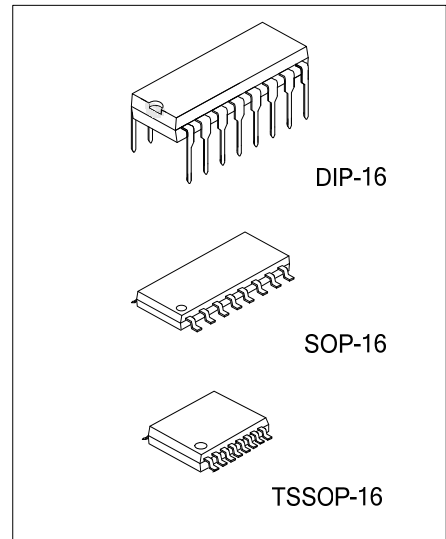

|   |  |
|---|--|
| <p>TL494L-D16-T</p> <p>(1)Packing Type<br/>(2)Package Type<br/>(3)Lead Free</p> | <p>(1) T: Tube, R: Tape Reel<br/>(2) D16: DIP-16, P16: TSSOP-16, S16: SOP-16<br/>(3) L: Lead Free, G: Halogen Free</p> |
|---|--|

## ■ PIN CONFIGURATION

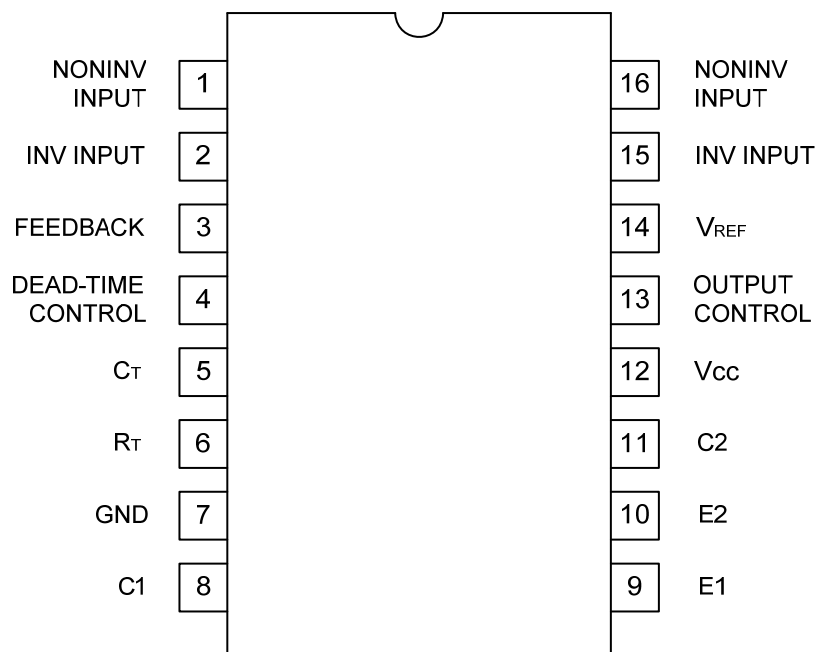

## ■ PIN DESCRIPTION

| PIN No. | SYMBOL            | NAME AND FUNCTION            |
|---------|-------------------|------------------------------|
| 1, 16   | NONINV INPUT      | Error Amplifier NONINV Input |
| 2, 15   | INV INPUT         | Error Amplifier INV Input    |
| 3       | FEEDBACK          | Output Feedback Voltage      |
| 4       | DEAD-TIME CONTROL | Output DEAD-TIME Control     |
| 5       | CT                | Timing Capacitor             |
| 6       | RT                | Timing Resistor              |
| 7       | GND               | Ground                       |
| 8       | C1                | Internal Power NPN Collect1  |
| 9       | E1                | Internal Power NPN Emitter1  |
| 10      | E2                | Internal Power NPN Emitter2  |
| 11      | C2                | Internal Power NPN Collect2  |
| 12      | VCC               | Supply Voltage               |
| 13      | OUTPUT CONTROL    | Output mode select           |
| 14      | VREF              | Reference Voltage            |

## ■ BLOCK DIAGRAM

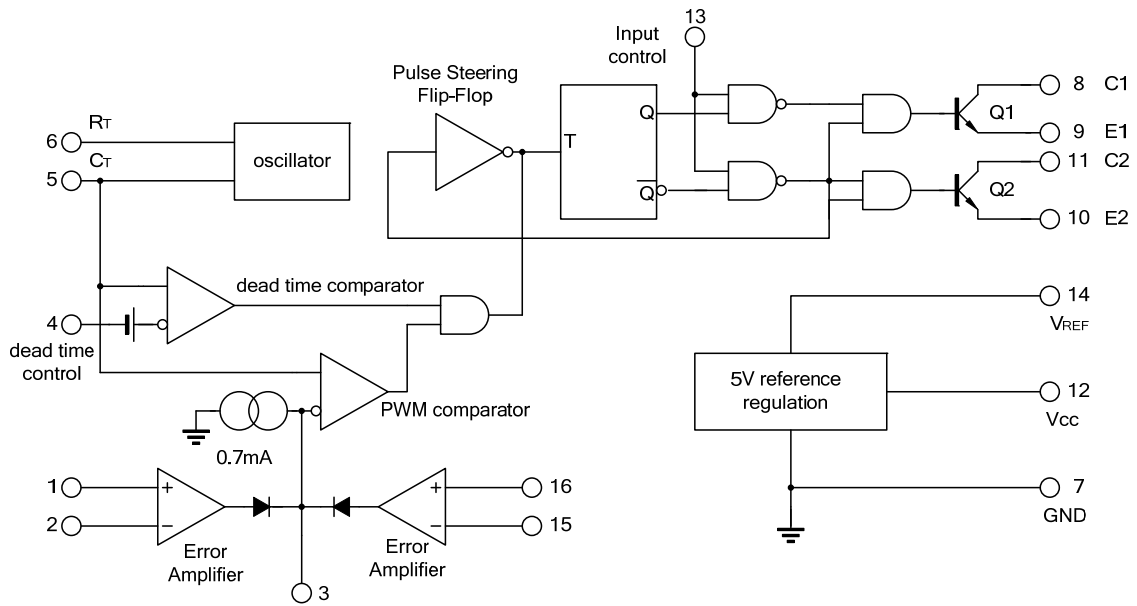

## ■ ABSOLUTE MAXIMUM RATINGS (unless otherwise specified)

| PARAMETER                                    | SYMBOL    | RATINGS      | UNIT                 |
|--|-----------|--------------|----------------------|
| Supply Voltage(Note 3)                       | $V_{CC}$  | 41           | V                    |
| Amplifier Input Voltage                      | $V_{IN}$  | $V_{CC}+0.3$ | V                    |
| Collector Output Voltage                     | $V_{OUT}$ | 41           | V                    |
| Collector Output Current                     | $I_{CO}$  | 250          | mA                   |
| Power Dissipation ( $T_A=25^\circ\text{C}$ ) | $P_D$     | 1000         | mW                   |
| Derate at $T_A > 25^\circ\text{C}$           |           | 9.2          | mW/ $^\circ\text{C}$ |
| Junction Temperature                         | $T_J$     | 125          | $^\circ\text{C}$     |
| Operating Temperature                        | $T_{OPR}$ | -25 ~ +85    | $^\circ\text{C}$     |
| Storage Temperature                          | $T_{STG}$ | -40 ~ +150   | $^\circ\text{C}$     |

Note 1. Absolute maximum ratings are those values beyond which the device could be permanently damaged.

Absolute maximum ratings are stress ratings only and functional device operation is not implied.

2. All voltage values, except differential voltages are with respect to the network ground terminal.

## ■ RECOMMENDED OPERATING CONDITIONS

| PARAMETER                                  | SYMBOL    | MIN  | TYP | MAX        | UNIT             |
|--|-----------|------|-----|------------|------------------|
| Supply Voltage                             | $V_{CC}$  | 7    |     | 40         | V                |
| Amplifier Input Voltage                    | $V_{IN}$  | -0.3 |     | $V_{CC}-2$ | V                |
| Collector Output Voltage                   | $V_{OUT}$ |      |     | 40         | V                |
| Collector Output Current (each Transistor) | $I_C$     |      |     | 200        | mA               |
| Current into Feedback                      | $I_f$     |      |     | 0.3        | mA               |
| Timing Capacitor                           | $C_T$     | 0.47 |     | 10000      | nF               |
| Timing Resistor                            | $R_T$     | 1.8  |     | 500        | k $\Omega$       |
| Oscillator Frequency                       | $f_{OSC}$ | 1    |     | 300        | kHz              |
| Operating Free-Air Temperature             | $T_A$     | 0    |     | 70         | $^\circ\text{C}$ |

## ■ ELECTRICAL CHARACTERISTICS

(Over recommended operating free-air temperature range,  $V_{CC}=15\text{V}$ ,  $f=1\text{kHz}$ , unless otherwise specified)

| PARAMETER                              | SYMBOL      | TEST CONDITIONS  | MIN  | TYP | MAX  | UNIT |
|--|-------------|--|------|-----|------|------|
| <b>REFERENCE SECTION</b>               |             |  |      |     |      |      |
| Output Voltage                         | $V_{OUT}$   | $I_{OUT}=1\text{mA}$   | 4.75 | 5   | 5.25 | V    |
| Input Regulation                       | $V_{IN}$    | $V_{CC}=7\text{V} \sim 40\text{V}$   |      | 2   | 25   | mV   |
| Output Regulation                      | $V_{OUT}$   | $I_{OUT}=1 \sim 10\text{mA}$   |      | 1   | 15   | mV   |
| Output Voltage Change with Temperature |             | $\Delta T_A=\text{MIN} \sim \text{MAX}(\text{note } 2)$                                  |      | 0.2 | 1    | %    |
| Short-Circuit Output Current           | $I_{O(SC)}$ | $V_{REF}=0$  |      | 35  |      | mA   |
| <b>OSCILLATOR SECTION</b>              |             |  |      |     |      |      |
| Frequency                              | F           | $C_T=0.01\mu\text{F}$ , $R_T=12\text{k}\Omega$   |      | 10  |      | kHz  |
| Standard Deviation of Frequency        |             | All Values of $V_{CC}$ , $C_T$ , $R_T$ , $T_A$ constant                                  |      | 10  |      | %    |
| Frequency Change with Voltage          |             | $V_{CC}=7\text{V} \sim 40\text{V}$ , $T_A=25^\circ\text{C}$                              |      | 0.1 |      | %    |
| Frequency Change with Temperature      |             | $C_T=0.01\mu\text{F}$ , $R_T=12\text{k}\Omega$ , $\Delta T_A=\text{MIN} \sim \text{MAX}$ |      |     | 12   | %    |

## ■ ELECTRICAL CHARACTERISTICS(Cont.)

| PARAMETER   |                  | SYMBOL          | TEST CONDITIONS  | MIN                  | TYP | MAX  | UNIT    |
|---|------------------|-----------------|--|----------------------|-----|------|---------|
| <b>AMPLIFIER SECTION</b>                                      |                  |                 |  |                      |     |      |         |
| Input Offset Voltage  | Error            | $V_{I(OFF)}$    | $V_{OUT}(\text{pin } 3)=2.5V$                          |                      | 2   | 10   | mV      |
| Input Offset Current  |                  | $I_{I(OFF)}$    | $V_{OUT}(\text{pin } 3)=2.5V$                          |                      | 25  | 250  | nA      |
| Input Bias Current  |                  | $I_{I(BIAS)}$   | $V_{OUT}(\text{pin } 3)=2.5V$                          |                      | 0.2 | 1    | $\mu A$ |
| Common-Mode Input Voltage Range                               | Error            |                 | $V_{CC}=7V \sim 40V$                                   | -0.3 ~<br>$V_{CC}-2$ |     |      | V       |
| Open-Loop Voltage Amplification                               |                  |                 | $\Delta V_{OUT}=3V, V_{OUT}=0.5V \sim 3.5V$            | 70                   | 95  |      | dB      |
| Unity-Gain Bandwidth  |                  | $GB_W$          |  |                      | 800 |      | kHz     |
| Common-Mode Rejection Ratio                                   | Error            | CMRR            | $V_{CC}=40V, T_A=25^\circ C$                           | 65                   | 80  |      | dB      |
| Output Sink Current(pin 3)                                    |                  | $I_{O(SINK)}$   | $V_{ID}=-15mV \sim -5V, V(\text{pin } 3)=0.5V$         | 0.3                  | 0.7 |      | mA      |
| Output source Current(pin 3)                                  |                  | $I_{O(SOURCE)}$ | $V_{ID}=15mV \sim -5V, V(\text{pin } 3)=3.5V$          | -2                   |     |      | mA      |
| <b>OUTPUT SECTION</b>   |                  |                 |  |                      |     |      |         |
| Collector off-state current                                   |                  | $I_{C(OFF)}$    | $V_{CE}=40V, V_{CC}=40V$                               |                      | 2   | 100  | $\mu A$ |
| Emitter off-state Current                                     |                  | $I_{E(OFF)}$    | $V_{CC}=V_C=40V, V_E=0$                                |                      |     | -100 | $\mu A$ |
| Collector -emitter Saturation Voltage                         | Common-emitter   |                 | $V_E=0, I_C=200mA$                                     |                      | 1.1 | 1.3  | V       |
|   | Emitter-Follower |                 | $V_C=15V, I_E=-200mA$                                  |                      | 1.5 | 2.5  |         |
| Output Control Input Current                                  |                  |                 | $V_{IN}=V_{REF}$                                       |                      |     | 3.5  | mA      |
| <b>DEAD TIME CONTROL SECTION</b>                              |                  |                 |  |                      |     |      |         |
| Input bias (pin 4)  |                  | $I_{I(BIAS)}$   | $V_{IN}=0 \sim 5.25V$                                  |                      | -2  | -10  | $\mu A$ |
| Maximum duty cycle, each output                               |                  |                 | $V_{IN}(\text{pin } 4)=0$                              | 45                   |     |      | %       |
| Input threshold Voltage(pin 4)                                |                  | $V_{THR}$       | Zero duty Cycle  |                      | 3   | 3.3  | V       |
|   |                  |                 | Maximum duty cycle                                     | 0                    |     |      |         |
| <b>PWM COMPARATOR SECTION</b>                                 |                  |                 |  |                      |     |      |         |
| Input Threshold Voltage(pin 3)                                |                  | $V_{THR}$       | Zero Duty cycle  |                      | 4   | 4.5  | V       |
| Input Sink Current (pin 3)                                    |                  | $I_{I(SINK)}$   | $V(\text{pin } 3)=0.7V$                                | 0.3                  | 0.7 |      | mA      |
| <b>TOTAL DEVICE</b>   |                  |                 |  |                      |     |      |         |
| Standby Supply Current  | $V_{CC}=15V$     | $I_{ST-BY}$     | pin 6 at $V_{REF}$ , all other Inputs and outputs open |                      | 6   | 10   | mA      |
|   | $V_{CC}=40V$     |                 |  |                      | 9   | 15   |         |
| Average supply current  |                  |                 | $V(\text{pin } 4)=2V$                                  |                      | 7.5 |      | mA      |
| <b>SWITCHING CHARACTERISTICS, <math>T_A=25^\circ C</math></b> |                  |                 |  |                      |     |      |         |
| Output Voltage Rise Time                                      |                  | $t_R$           | Common-emitter configuration                           |                      | 100 | 200  | ns      |
| Output Voltage Fall Time                                      |                  | $t_F$           |  |                      | 25  | 100  | ns      |
| Output Voltage Rise Time                                      |                  | $t_R$           | Emitter-follower configuration                         |                      | 100 | 200  | ns      |
| Output Voltage Fall Time                                      |                  | $t_F$           |  |                      | 40  | 100  | ns      |

- Notes: 1. All typical Values except for temperature coefficient are at  $T_A=25^\circ C$ .  
 2. For conditions shown as MIN or MAX, use appropriate value under recommended operating conditions.  
 3. Duration of the short-circuit should not exceed one second.  
 4. Standard deviation is a measure of the statistical distribution the mean as derived from the formula:

$$\sigma = \sqrt{\frac{\sum_{n=1}^N (x_n - \bar{x})^2}{N-1}}$$

## ■ TEST CIRCUIT

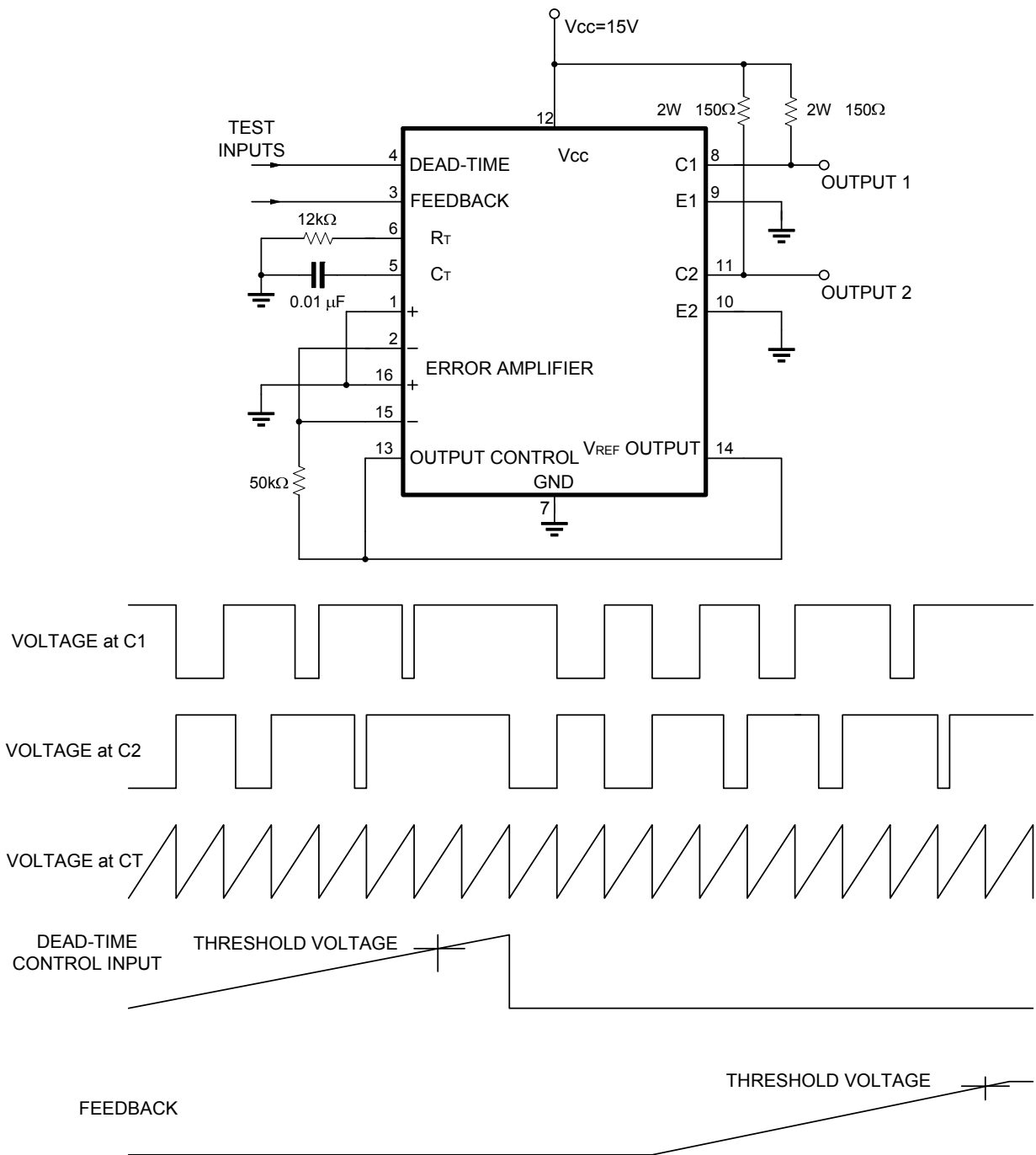

FIG 1. OPERATIONAL TEST CIRCUIT AND WAVEFORMS

■ TEST CIRCUIT(Cont.)

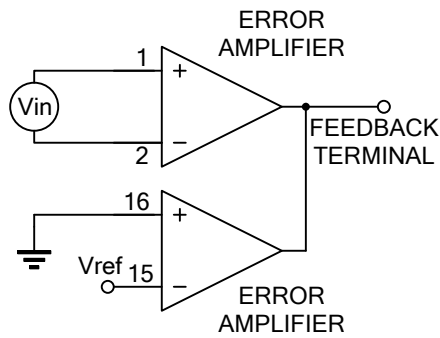

Fig. 2 AMPLIFIER CHARACTERISTICS

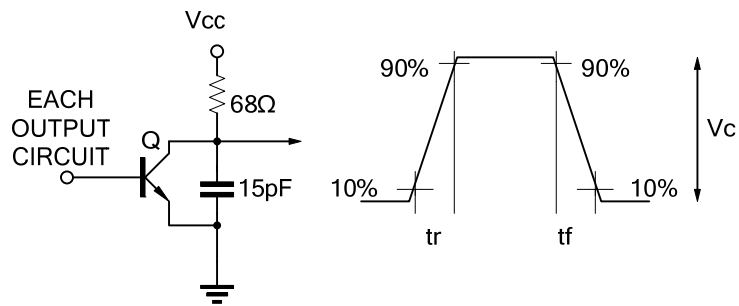

Fig. 3 COMMON-EMITTER CONFIGURATION

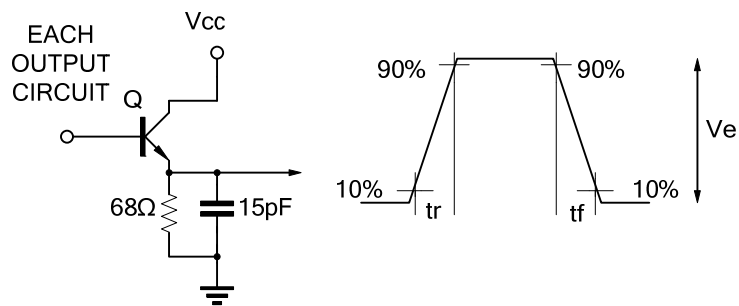
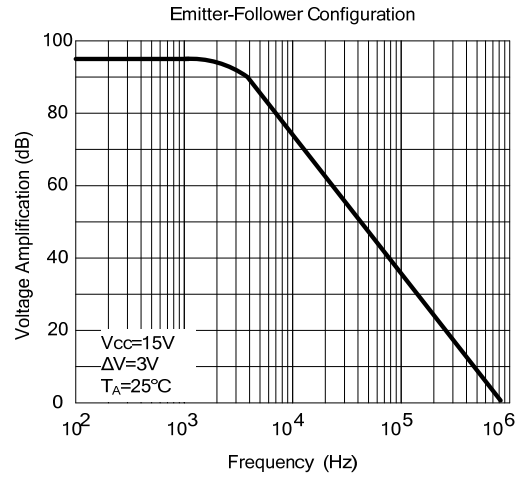
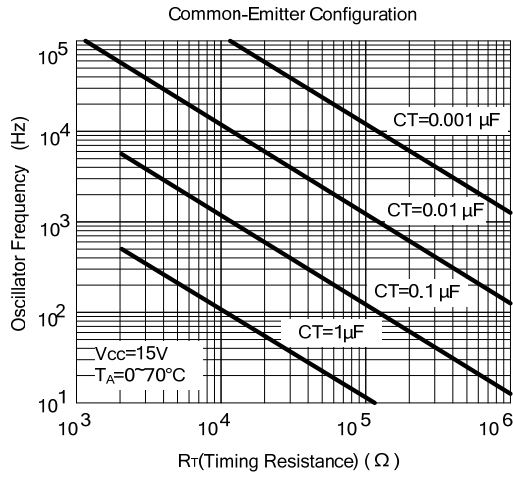

Fig. 4 EMITTER -FOLLOWER CONFIGURATION

■ TYPICAL PERFORMANCE CHARACTERISTICS



UTC assumes no responsibility for equipment failures that result from using products at values that exceed, even momentarily, rated values (such as maximum ratings, operating condition ranges, or other parameters) listed in products specifications of any and all UTC products described or contained herein. UTC products are not designed for use in life support appliances, devices or systems where malfunction of these products can be reasonably expected to result in personal injury. Reproduction in whole or in part is prohibited without the prior written consent of the copyright owner. The information presented in this document does not form part of any quotation or contract, is believed to be accurate and reliable and may be changed without notice.