



ADVANCED PWM STEP-UP DC-DC CONVERTER

DESCRIPTION

The UTC UC3551 is a step-up DC/DC converter with high efficiency and low start-up voltage. It is operated in stable waveforms without external compensate. This device incorporates an adaptive current mode PWM control loop in which an error amplifier, ramp generator, comparator, switch pass element and driver are included. Besides, this circuit provides a stable and high efficient operation over a wide range of load currents.

The UTC UC3551 features high switching rate which is up to 450 KHz, making the external component counts less required. Moreover, it features 17µA low quiescent current, which makes the battery life longer. The low start-up input voltage below 1V makes UTC UC3551 suitable for 1 to 4 battery cells applications of providing up to 300mA output current.

Two external resistors determine the value of the output voltage. The external power devices (NMOS or NPN) are derived by both internal 2A switch and driver.

The UTC UC3551 is intended to be used in PDA, DSC, LCD Panel, RF-Tags, MP3, portable instrument and wireless equipment.

FEATURES

- * Low Start-up Input Voltage is as Low as 1.0V
- * Efficiency up to 90%
- * High Supply Capability to Deliver 3.3V 100mA with 1 Alkaline Cell
- * Quiescent (Switch-off) Supply Current: 17µA
- * Zero Shutdown Mode Supply Current
- * Fixed Switching Frequency: 450KHz
- * Both Internal and External Power Switches for Maximum Flexibility

ORDERING INFORMATION

Ordering Number		Package	Packing
Lead Free	Halogen Free		
UC3551L-AG6-R	UC3551G-AG6-R	SOT-26	Tape Reel

<p>UC3551L-AG6-R</p> <p>(1) Packing Type (2) Package Type (3) Lead Free</p>	<p>(1) R: Tape Reel (2) AG6: SOT-26 (3) G: Halogen Free, L: Lead Free</p>
---	---

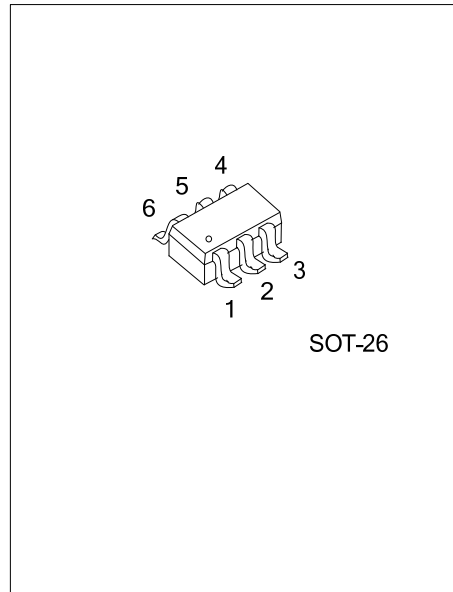

■ MARKING INFORMATION

PACKAGE	VOLTAGE CODE	MARKING
SOT-26	AD:ADJ	

■ PIN CONFIGURATION

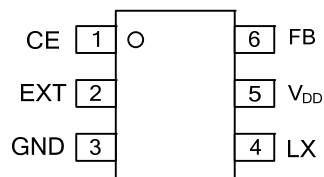

■ PIN DESCRIPTION

PIN NO.	PIN NAME	DESCRIPTION
1	CE	Chip enable UC3551 gets into shutdown mode when CE pin set to low.
2	EXT	Output pin for driving external NMOS
3	GND	Ground
4	LX	Pin for switching
5	V _{DD}	Input positive power pin of UC3551
6	FB	Feedback input pin Internal reference voltage for the error amplifier is 1.25V.

■ BLOCK DIAGRAM

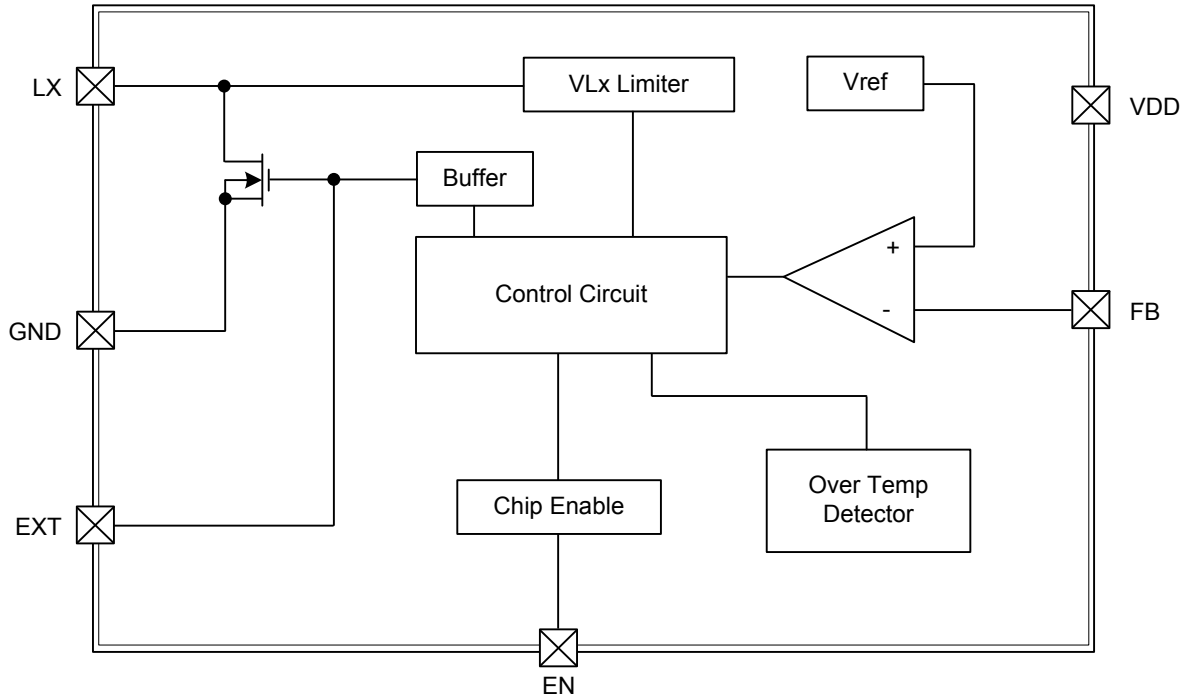

■ ABSOLUTE MAXIMUM RATING

PARAMETER	SYMBOL	RATINGS	UNIT
Supply Voltage	V_{IN}	- 0.3 ~ 7	V
LX Pin Switch Voltage	V_{LX}	- 0.3 ~ ($V_{DD} + 0.8$)	V
Other I/O Pin Voltages		- 0.3 ~ ($V_{DD} + 0.3$)	V
LX Pin Switch Current	I_{LX}	2.5	A
EXT Pin Driver Current	I_{EXT}	200	mA
Operating Junction Temperature	T_{OPR}	125	°C
Storage Temperature	T_{STG}	-65~+150	°C

Notes: Absolute maximum ratings are those values beyond which the device could be permanently damaged.
Absolute maximum ratings are stress ratings only and functional device operation is not implied.

■ THERMAL DATA

PARAMETER	SYMBOL	RATINGS	UNIT
Junction to Case	θ_{JC}	145	°C/W

■ ELECTRICAL CHARACTERISTICS

($T_A = 25^\circ\text{C}$, $V_{IN} = 1.5\text{V}$, $V_{DD} = 3.3\text{V}$, Load Current = 0, unless otherwise specified)

PARAMETER	SYMBOL	CONDITIONS	MIN	TYP	MAX	UNIT
Start-UP Voltage	V_{ST}	$I_L = 1\text{mA}$		0.98	1.05	V
Operating VDD Range	V_{DD}	V_{DD} pin voltage	2		6.5 (Note)	V
No Load Current I (V_{IN})	I_{NO_LOAD}	$V_{IN} = 1.5\text{V}$, $V_{OUT} = 3.3\text{V}$		75		μA
Switch-off Current I (V_{DD})	I_{SWITCH_OFF}	$V_{IN} = 6\text{V}$		17		μA
Shutdown Current I (V_{IN})	I_{OFF}	CE Pin = 0V, $V_{IN} = 4.5\text{V}$		0.01	1	μA
Feedback Reference Voltage	V_{REF}	Close Loop, $V_{DD} = 3.3\text{V}$	1.225	1.25	1.275	V
Switching Frequency	F_S	$V_{DD} = 3.3\text{V}$		450		KHz
Maximum Duty	D_{MAX}	$V_{DD} = 3.3\text{V}$		95		%
LX ON Resistance		$V_{DD} = 3.3\text{V}$		0.3		Ω
Current Limit Setting	I_{LIMIT}	$V_{DD} = 3.3\text{V}$		2		A
EXT ON Resistance to V_{DD}		$V_{DD} = 3.3\text{V}$		5		Ω
EXT ON Resistance to GND		$V_{DD} = 3.3\text{V}$		5		Ω
Line Regulation	ΔV_{LINE}	$V_{IN} = 1.5 \sim 2.5\text{V}$, $I_L = 1\text{mA}$		10		mV/V
Load Regulation	ΔV_{LOAD}	$V_{IN} = 2.5\text{V}$, $I_L = 1 \sim 100\text{mA}$		0.25		mV/mA
CE Pin Trip Level		$V_{DD} = 3.3\text{V}$	0.4	0.8	1.2	V
Temperature Stability for Vout	T_s			50		ppm/°C
Thermal Shutdown	T_{SD}			165		°C
Thermal Shutdown Hysterises	ΔT_{SD}			10		°C

Note: The CE pin shall be tied to V_{DD} pin and inhibit to act the ON/OFF state whenever the V_{DD} pin voltage may reach to 5.5V or above.

■ TEST CIRCUIT

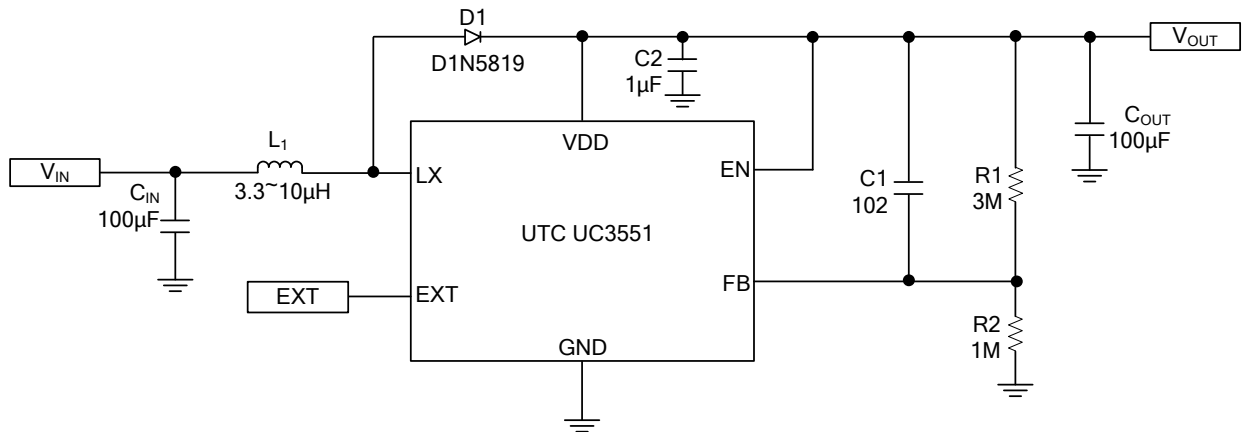

■ TYPICAL APPLICATION CIRCUIT

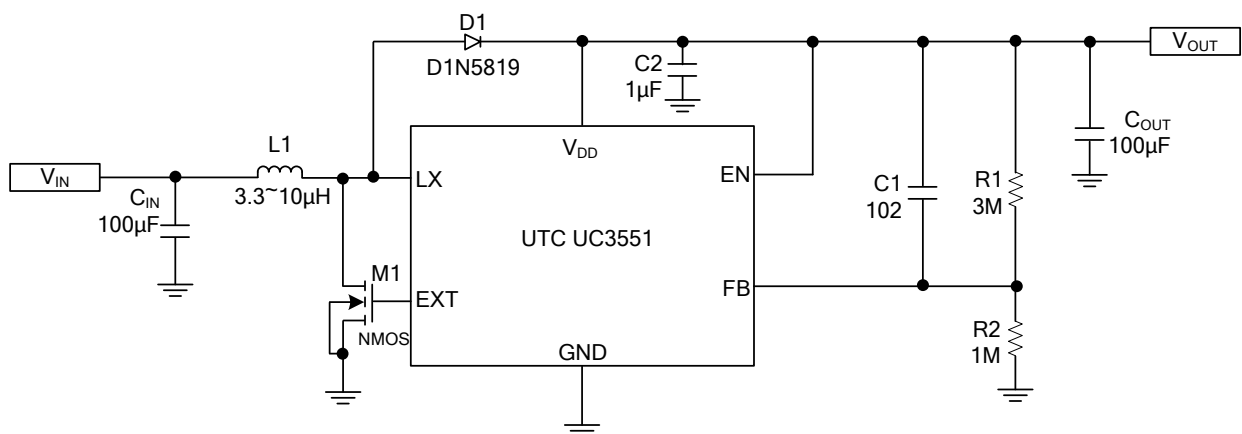
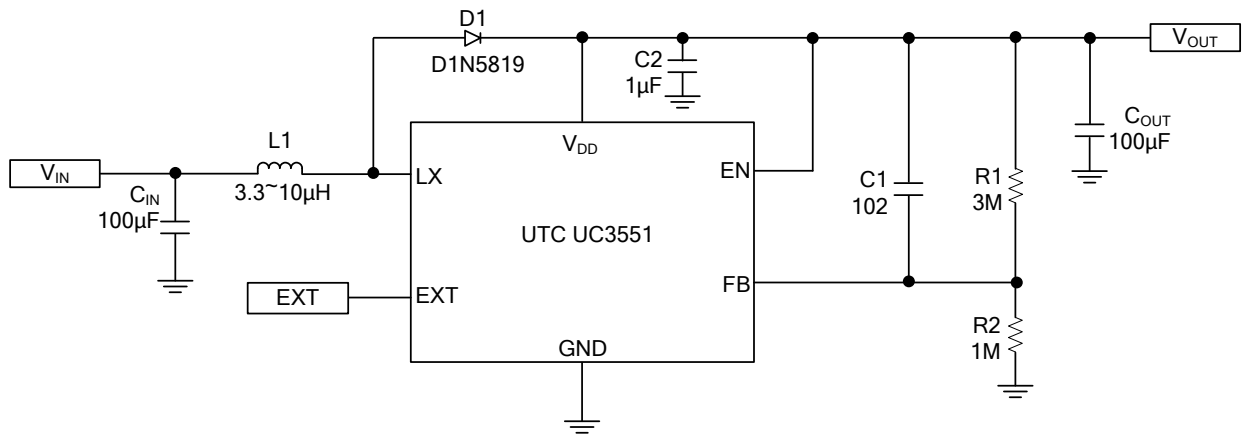

UTC assumes no responsibility for equipment failures that result from using products at values that exceed, even momentarily, rated values (such as maximum ratings, operating condition ranges, or other parameters) listed in products specifications of any and all UTC products described or contained herein. UTC products are not designed for use in life support appliances, devices or systems where malfunction of these products can be reasonably expected to result in personal injury. Reproduction in whole or in part is prohibited without the prior written consent of the copyright owner. The information presented in this document does not form part of any quotation or contract, is believed to be accurate and reliable and may be changed without notice.