



P1886

LINEAR INTEGRATED CIRCUIT

PWM CONTROL 3A STEP-DOWN CONVERTER

DESCRIPTION

UTC **P1886** consists of 3A step-down switching regulator control which includes a reference voltage source, oscillation circuit, error amplifier, internal PMOS and etc with PWM.

UTC **P1886** can provide low-ripple power, high efficiency, and excellent transient characteristics and an enable function, an over current protect function and a short circuit protect function are built inside, so the operation frequency will be reduced from 300KHz to 30KHz when OCP or SCP happens. And the PWM control circuit can vary the duty ratio linearly from 100 down to 0%. This converter also includes an error amplifier circuit as well as a soft-start circuit that prevents overshoot at startup. Also, to minimum external component count an internal compensation block is built in.

UTC **P1886** can work as step-down switching regulators with the addition of an internal P-channel Power MOS, a coil, capacitors, and a diode connected externally. It provides such outstanding features: low current consumption. It is also suitable for the operation via an AC adapter because this converter can accommodate an input voltage up to 23V.

FEATURES

- * Soft-start, Current Limit, Enable function
- * Thermal Shutdown function
- * Built-in internal SW P-channel MOS
- * Input voltage: 4V to 23V.
- * Output voltage: 0.8V to V_{CC} .
- * Duty ratio: 0% to 100% PWM control
- * Oscillation frequency: 300KHz typ.

ORDERING INFORMATION

Ordering Number		Package	Packing
Lead Free	Halogen Free		
P1886L-S08-R	P1886G-S08-R	SOP-8	Tape Reel

<p>P1886L-S08-R</p> <p>(1)Packing Type (2)Package Type (3)Lead Plating</p>	<p>(1) R: Tape Reel (2) S08: SOP-8 (3) G: Halogen Free, L: Lead Free</p>
--	--

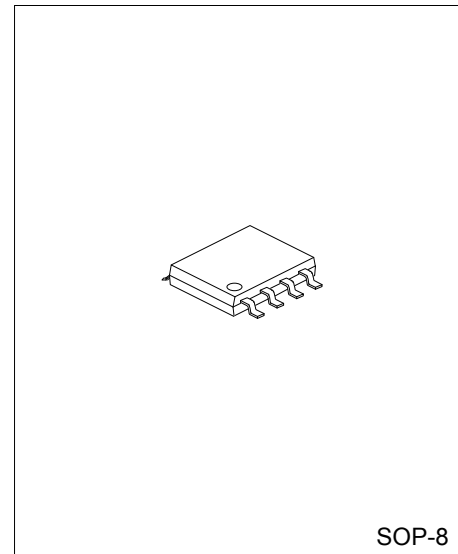

SOP-8

■ PIN CONNECTIONS

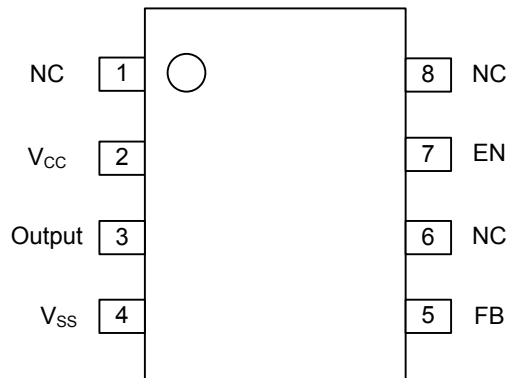

■ PIN DESCRIPTIONS

PIN NO	NAME	DESCRIPTION
2	V _{CC}	IC power supply pin
3	Output	Switch Pin. Connect external inductor/diode here. Minimize trace area at this pin to reduce EMI.
4	V _{SS}	GND
5	FB	Feedback pin.
7	EN	Power-off pin H: Normal operation (Step-down operation) L: Step-down operation stopped (All circuits deactivated)

■ BLOCK DIAGRAM

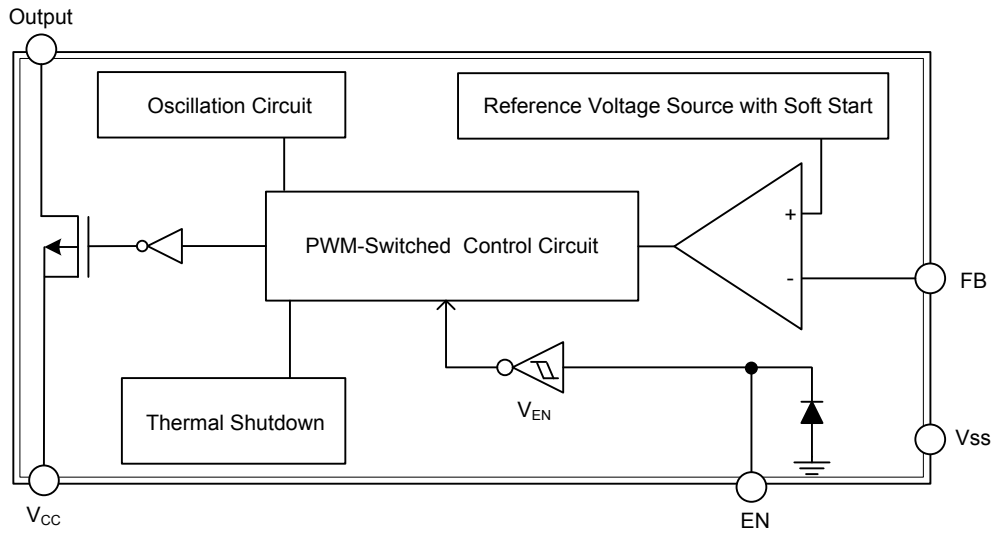

■ ABSOLUTE MAXIMUM RATINGS

PARAMETER	SYMBOL	RATING	UNIT
V _{CC} Pin Voltage	V _{CC}	V _{SS} -0.3 ~ V _{SS} +25	V
Feedback Pin Voltage	V _{FB}	V _{SS} -0.3 ~ V _{CC}	V
EN Pin Voltage	V _{EN}	V _{SS} -0.3 ~ V _{IN} +0.3	V
Switch Pin Voltage	V _{OUTPUT}	V _{SS} -0.3 ~ V _{IN} +0.3	V
Power Dissipation	P _D	Internally limited	mW
Operating Ambient Temperature	T _a	-20 ~ +85	°C
Operating Temperature	T _{OPR}	-20 ~ +125	°C
Storage Temperature	T _{STG}	-40 ~ +150	°C

Note: Absolute maximum ratings are those values beyond which the device could be permanently damaged.

Absolute maximum ratings are stress ratings only and functional device operation is not implied.

■ THERMAL DATA

PARAMETER	SYMBOL	MIN	TYP	MAX	UNIT
Junction to Ambient	θ _{JA}			134	°C/W
Junction to Case	θ _{JC}			22	°C/W

■ ELECTRICAL CHARACTERISTICS (T_a=25°C, V_{IN}=12V, unless otherwise specified)

PARAMETER	SYMBOL	CONDITIONS	MIN.	TYP.	MAX.	UNIT
Input Voltage	V _{IN}		4		23	V
Feedback Voltage	V _{FB}	I _{OUT} =0.1A	0.784	0.8	0.816	V
Feedback Bias Current	I _{FB(BIAS)}	I _{OUT} =0.1A		0.1	0.5	μA
Switch Current	I _{SW}		3.5			A
Standby Current	I _{STN-BY}	V _{EN} =0V		10		μA
Line Regulation	$\frac{\Delta V_{OUT}}{V_{OUT}}$	V _{IN} =5V~23V, I _{OUT} =0.2A		1	2	%
Load Regulation	$\frac{\Delta V_{OUT}}{V_{OUT}}$	I _{OUT} =0.1~3A		0.2	0.5	%
Oscillation Frequency	f _{OSC}	Measure waveform at SW pin	240	300	360	KHz
Frequency of Current Limit or Short Circuit Protect	f _{OSC1}	Measure waveform at SW pin	10			KHz
EN Pin Input Voltage	V _{SH}	Evaluate oscillation at SW pin		0.79		V
	V _{SL}	Evaluate oscillation stop at SW pin		0.72		V
EN Pin Input Leakage Current	I _{SH}			20		μA
	I _{SL}			-10		μA
Soft-Start Time	T _{SS}		0.3	2	5	ms
Internal MOSFET R _{DS(ON)}	R _{DS(ON)}	V _{IN} =5V, V _{FB} =0V		110	150	mΩ
		V _{IN} =12V, V _{FB} =0V		70	100	mΩ
Efficiency	η	V _{IN} =12V, V _{OUT} =5V, I _{OUT} =3A		88		%

■ FUNCTION DESCRIPTION

PWM Control

The UTC **P1886** consists of DC/DC converters which employ a PWM system. In this DC/DC converter, the pulse width varies in a range from 0 to 100% which is according to the load current. Cause the switching frequency remains constant the ripple voltage which produced by the switching can be removed easily through a filter. Therefore, these converters provide a low-ripple power over broad ranges of input voltage and load current.

TEST CIRCUITS

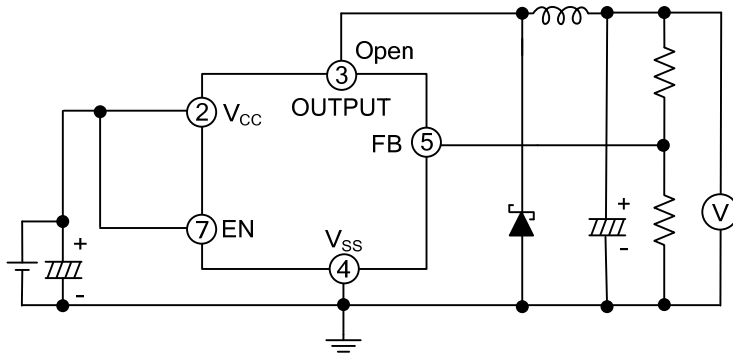
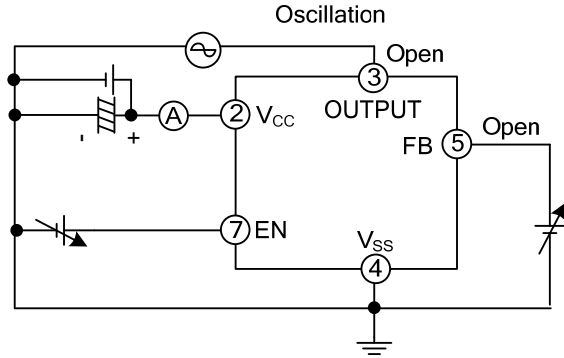
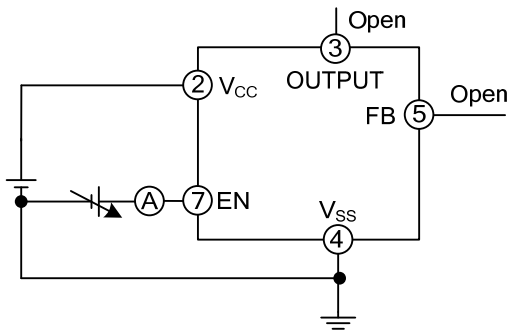

TYPICAL APPLICATION CIRCUIT

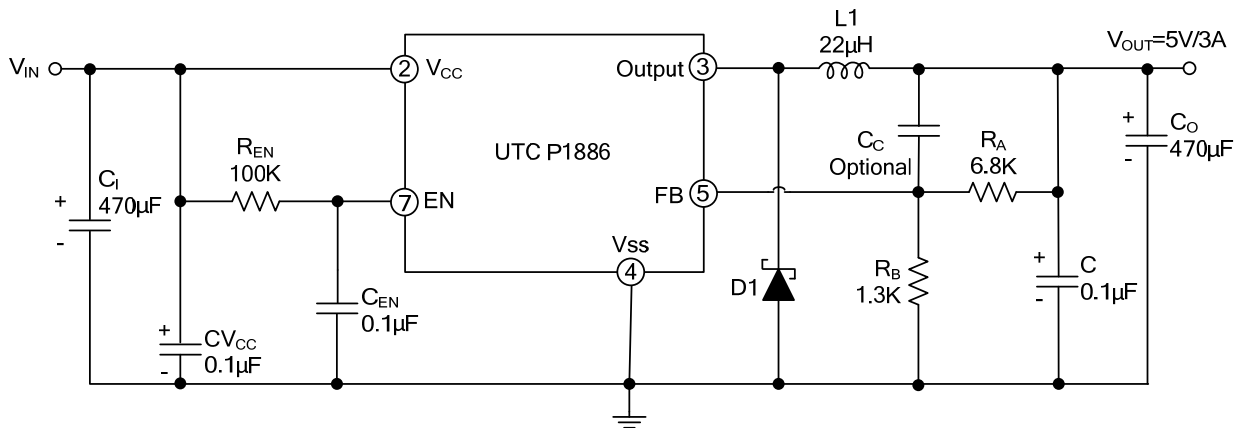

Note: $V_{OUT} = V_{FB} \times (1 + R_A/R_B)$, $R_B = 0.7K \sim 5K \text{ ohm}$

$V_{IN} = 12V, I_{MAX} = 3A$			
V_{OUT}	2.5V	3.3V	5V
L_1 Value	15µH	18µH	22µH

■ TYPICAL CHARACTERISTICS

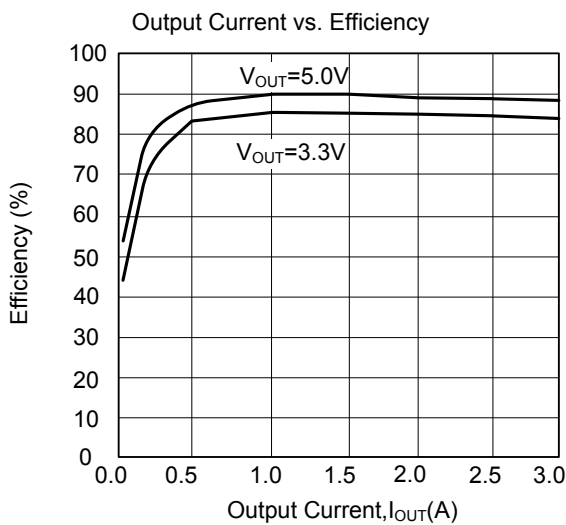
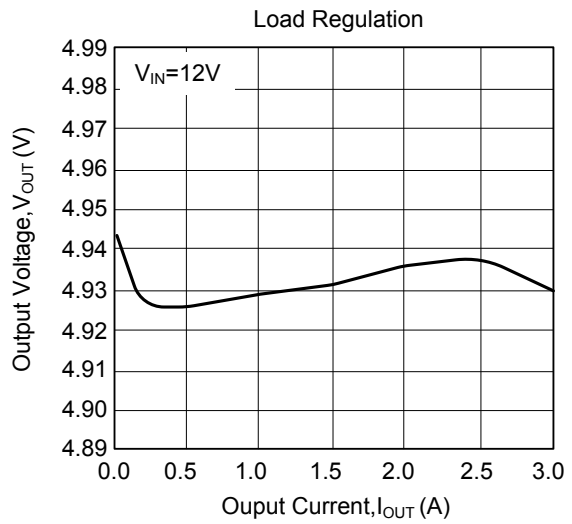
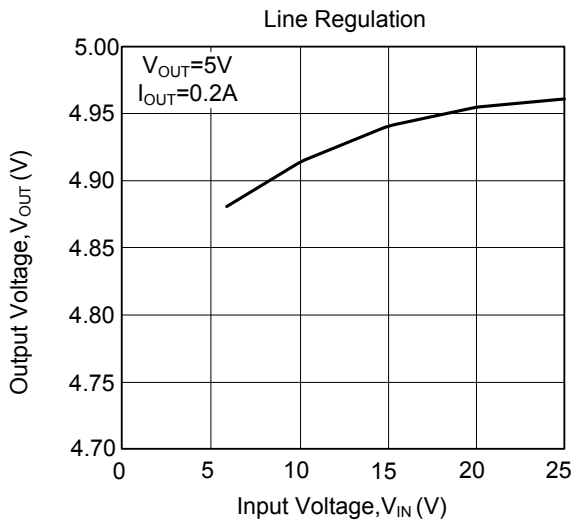
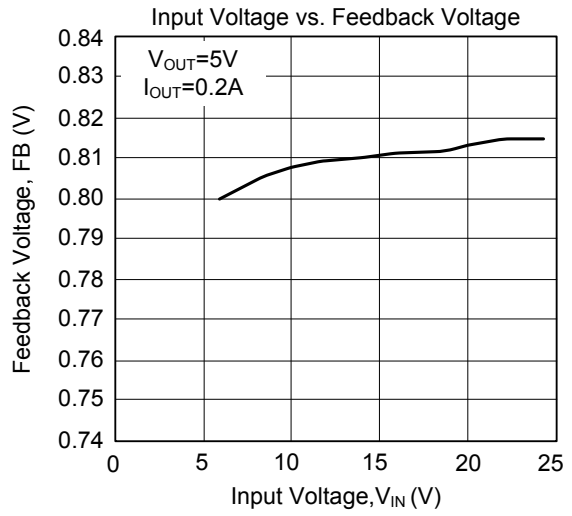
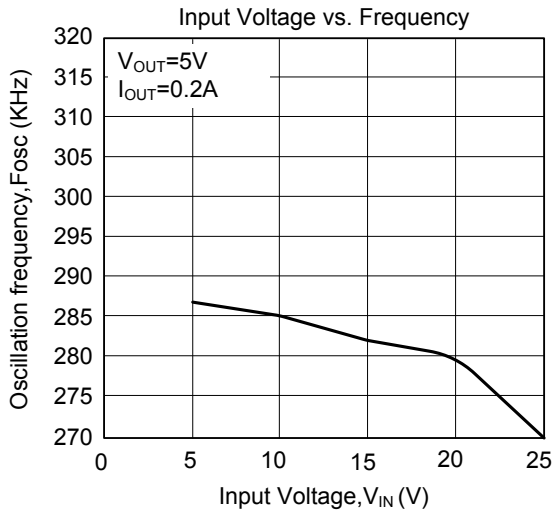

UTC assumes no responsibility for equipment failures that result from using products at values that exceed, even momentarily, rated values (such as maximum ratings, operating condition ranges, or other parameters) listed in products specifications of any and all UTC products described or contained herein. UTC products are not designed for use in life support appliances, devices or systems where malfunction of these products can be reasonably expected to result in personal injury. Reproduction in whole or in part is prohibited without the prior written consent of the copyright owner. The information presented in this document does not form part of any quotation or contract, is believed to be accurate and reliable and may be changed without notice.