



TL432C

LINEAR INTEGRATED CIRCUIT

1.24V PRECISION ADJUSTABLE SHUNT REFERENCE REGULATORS

DESCRIPTION

The UTC **TL432C** is a three-terminal adjustable shunt regulator highly accurate 1.24V band gap reference with 1%, 2% tolerance. The device offers thermal stability, wide operating current (50mA) and an extended temperature range of 0°C to 85°C for operation in power supply applications. The UTC **TL432C** offers a wide operating voltage range of up to 12V and is an excellent choice for voltage reference requirements in an isolated feedback circuit for 3.0V ~ 3.3V switching mode power supplies. The tight tolerance guarantees a lower design cost for the power supply manufacturer by virtually eliminating the need for an extra power supply manufacturing process of the power supply.

FEATURES

- *Temperature-Compensated: 50ppm/°C
- *Internal Amplifier with 50mA Capability
- *Nominal Temperature Range Extended to 85°C
- *Low Frequency Dynamic Output Impedance:<150mΩ
- *Low Output Noise

ORDERING INFORMATION

Ordering Number		Package	Pin Assignment								Packing
Lead Free	Halogen Free		1	2	3	4	5	6	7	8	
TL432CL-AB3-R	TL432CG-AB3-R	SOT-89	R	A	K	-	-	-	-	-	Tape Reel
TL432CL-AE3-R	TL432CG-AE3-R	SOT-23	K	R	A	-	-	-	-	-	Tape Reel
TL432CL-AF5-R	TL432CG-AF5-R	SOT-25	X	X	K	R	A	-	-	-	Tape Reel
TL432CL-T92-B	TL432CG-T92-B	TO-92	R	A	K	-	-	-	-	-	Tape Box
TL432CL-T92-K	TL432CG-T92-K	TO-92	R	A	K	-	-	-	-	-	Bulk
TL432CL-T92-R	TL432CG-T92-R	TO-92	R	A	K	-	-	-	-	-	Tape Reel
TL432CL-S08-R	TL432CG-S08-R	SOP-8	K	A	A	X	X	A	A	R	Tape Reel
TL432CL-S08-T	TL432CG-S08-T	SOP-8	K	A	A	X	X	A	A	R	Tube

Note: Pin Code: C: Cathode A: Anode R: Reference X: No Connection

<p>TL432CL-AB3-R</p> <p>(1)Packing Type (2)Package Type (3)Lead Free</p>	<p>(1) B: Tape Box, K: Bulk, R: Tape Reel (2) AB3: SOT-89, AE3: SOT-23, AF5: SOT-25, S08:SOP-8, T92: TO-92 (3) G: Halogen Free, L: Lead Free</p>
--	--

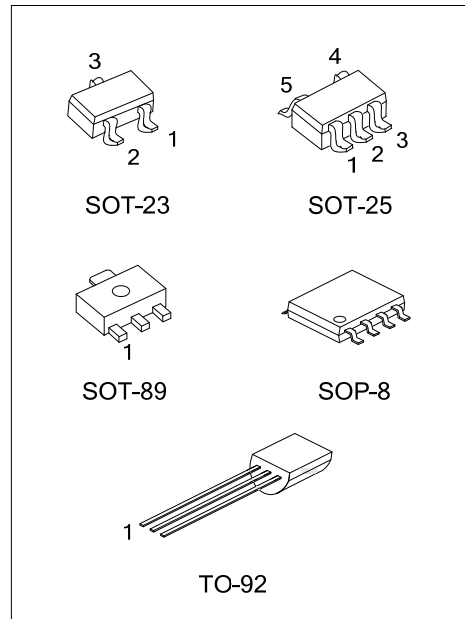

MARKING INFORMATION

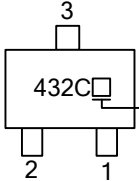
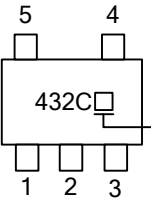
PACKAGE	MARKING
SOT-23	 <p>3 432C□ 2 1</p> <p>L: Lead Free G: Halogen Free</p>
SOT-25	 <p>5 4 432C□ 1 2 3</p> <p>L: Lead Free G: Halogen Free</p>

BLOCK DIAGRAM

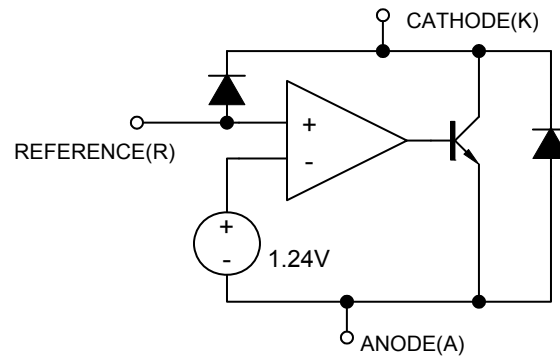

■ ABSOLUTE MAXIMUM RATINGS

PARAMETER	SYMBOL	RATINGS	UNIT
Cathode-Anode Reverse Breakdown	V_{KA}	15	V
Anode-Cathode Forward Current	I_{AK}	1	A
Operating Cathode Current	I_{KA}	50	mA
Reference Input Current	I_{REF}	1	mA
Junction Temperature	T_J	125	°C
Operating Temperature	T_{OPR}	-40 ~ +85	°C
Storage Temperature	T_{STG}	-40 ~ +150	°C

Note: Absolute maximum ratings are those values beyond which the device could be permanently damaged. Absolute maximum ratings are stress ratings only and functional device operation is not implied.

■ RECOMMENDED OPERATING CONDITIONS

PARAMETER	SYMBOL	RATINGS	UNIT
Cathode Voltage	V_{KA}	$V_{REF} \sim 15$	V
Cathode Current	I_K	5 ~ 10	mA

■ THERMAL DATA

PARAMETER	SYMBOL	RATING	UNIT	
Junction to Ambient	θ_{JA}	SOT-23/SOT-25	350	°C/W
		TO-92	100	°C/W
		SOP-8	150	°C/W
		SOT-89	220	°C/W

■ ELECTRICAL CHARACTERISTICS ($T_J=25^\circ\text{C}$, $V_{KA}=V_{REF}$, $I_K=10\text{mA}$, unless otherwise specified.)

PARAMETER	SYMBOL	TEST CONDITIONS	MIN	TYP	MAX	UNIT	
Reference Input Voltage	V_{REF}	$I_K=10\text{mA}$, $V_K=V_{REF}$	TL432C-A	1.234	1.24	1.246	V
			TL432C-1	1.228	1.24	1.252	
			TL432C-2	1.252		1.265	
			TL432C-3	1.215		1.228	
Line Regulation	ΔV_{REF}	$V_K=1.24 \sim 15\text{V}$		10	26	mV	
Load Regulation	ΔV_{REF}	$I_K=5 \sim 50\text{mA}$		6	15	mV	
Temperature Deviation	ΔV_{REF}	$-40 < T_J < 85^\circ\text{C}$		2	6	mV	
Reference Input Current	I_{REF}			3	6	μA	
Reference Input Current Temperature Coefficient	ΔI_{REF}	$-40 < T_J < 85^\circ\text{C}$		0.3	0.6	μA	
Minimum Cathode Current for Regulation	$I_{K(MIN)}$			0.6	1	mA	
Off State Leakage	$I_{KA(OFF)}$	$V_{REF}=0\text{V}$, $V_{KA}=15\text{V}$			500	nA	

UTC assumes no responsibility for equipment failures that result from using products at values that exceed, even momentarily, rated values (such as maximum ratings, operating condition ranges, or other parameters) listed in products specifications of any and all UTC products described or contained herein. UTC products are not designed for use in life support appliances, devices or systems where malfunction of these products can be reasonably expected to result in personal injury. Reproduction in whole or in part is prohibited without the prior written consent of the copyright owner. The information presented in this document does not form part of any quotation or contract, is believed to be accurate and reliable and may be changed without notice.