



UR5517

LINEAR INTEGRATED CIRCUIT

3A DDR BUS TERMINATION REGULATOR

DESCRIPTION

The UR5517 is a linear regulator which provides up to 3 Amp bi-directional sourcing and sinking capability for DDR1/2/3 SDRAM bus terminator applications. It only requires 20uF of ceramic output capacitance by a integrated operational amplifier which provides fast load transient response.

The UR5517 also includes two control pins, S3 & S5. If S3 were set in low level, V_{TT} will be turned off and left Hi-Z(sleep-state mode).If setting S5 were set in low level, both V_{TT} and V_{TTREF} will be turned off and discharged to ground(soft-off mode).

FEATURES

- * Input Voltage Range:3~5.5V
- * V_{LDOIN} Voltage Range:1.2V~3.6V
- * DDR1/2/3 Termination Voltage Applications
- * Sourcing and Sinking Current up to 3A
- * ±20mV Accuracy for V_{TT} and V_{TTREF}
- * 10mA Buffered Reference(V_{TTREF})
- * Supports High-Z in S3(STR) and Soft-off in S5(Shutdown)
- * Integrated Divider Tracks 1/2 V_{DDQSN3} for Both V_{TT}&V_{TTREF}
- * Built-In Soft-Start
- * Current Limiting Protection
- * Thermal Shutdown Protection

ORDERING INFORMATION

Ordering Number		Package	Packing
Lead Free	Halogen Free		
UR5517L-SM2-T	UR5517G-SM2-T	MSOP-10	Tube
UR5517L-SM2-R	UR5517G-SM2-R	MSOP-10	Tape Reel
UR5517L-SM1H-T	UR5517G-SM1H-T	HMSOP-8	Tube
UR5517L-SM1H-R	UR5517G-SM1H-R	HMSOP-8	Tape Reel

<p>UR5517L-SM1H-T</p> <p>(1)Packing Type</p> <p>(2)Package Type</p> <p>(3)Lead Free</p>	<p>(1) T: Tube, R: Tape Reel</p> <p>(2) SM1H: HMSOP-8, SM2: MSOP-10</p> <p>(3) L: Lead Free, G: Halogen Free</p>
---	--

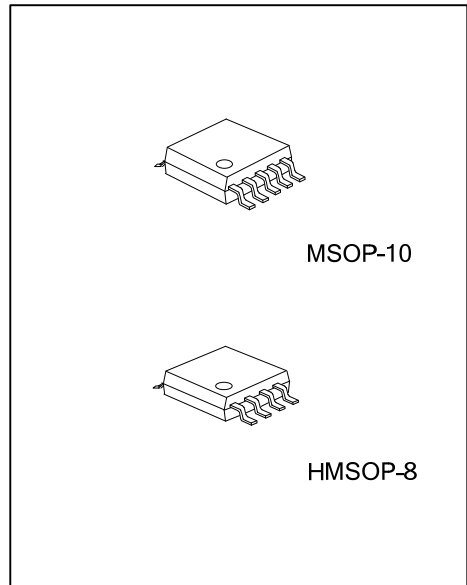

■ PIN CONFIGURATIONS

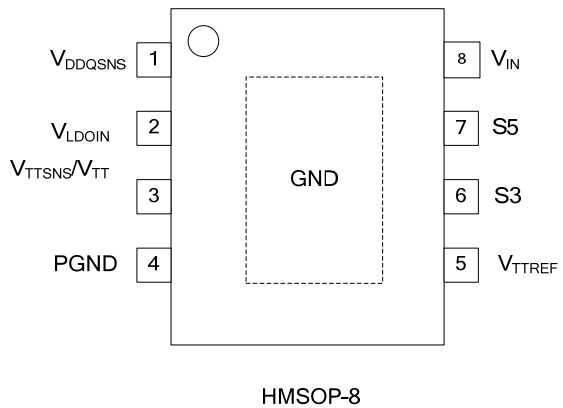
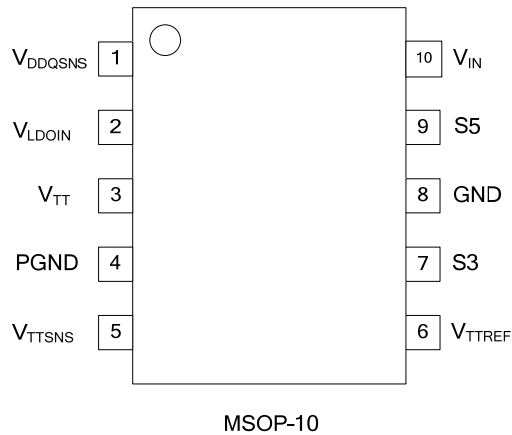

■ PIN DESCRIPTION (Note)

PIN No.		PIN NAME	PIN TYPE	PIN DESCRIPTION
HMSOP-8	MSOP-10			
1	1	V_{DDQSNS}	I	V_{DDQ} sense input
2	2	V_{LDOIN}	I	Power supply for the V_{TT} & V_{TTREF} output stage
3	3	V_{TT}	O	Output voltage for connection to termination resistors, equal to $V_{DDQSNS}/2$
4	4	PGND	O	Power ground output for the V_{TT} output
3	5	V_{TTSNS}	I	Voltage sense input for the V_{TT} . Connect to plus terminal of the output capacitor
5	6	V_{TTREF}	O	Buffered output that is a reference output, equal to $V_{DDQSNS}/2$
6	7	S3	I	Active low suspend to RAM mode control pin, V_{TT} is turned off and left Hi-Z
-	8	GND	I	Ground
7	9	S5	I	Active low shutdown control pin, both V_{TT} & V_{TTREF} are turned off and discharged to ground
8	10	V_{IN}	I	Analog input pin

Note: Recommend connecting the Thermal Pad to the GND for the excellent power dissipation.

■ BLOCK DIAGRAM

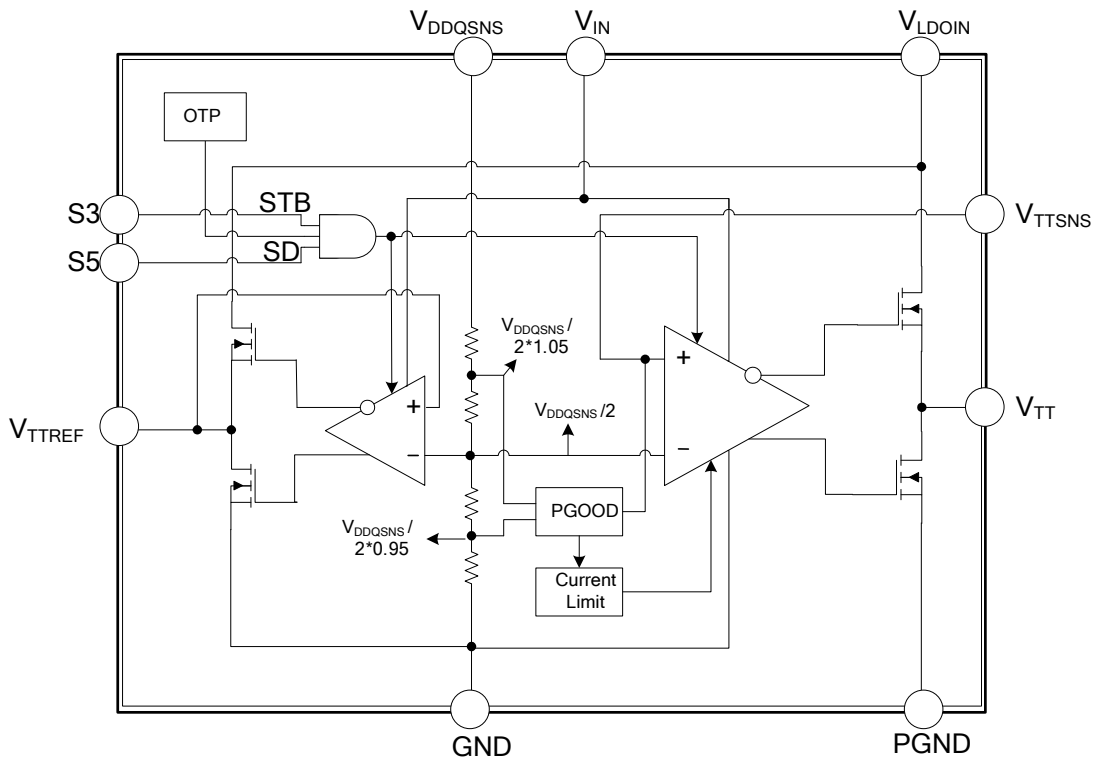

■ ABSOLUTE MAXIMUM RATING (unless otherwise specified)

PARAMETER	SYMBOL	RATINGS	UNIT
Supply Voltage($V_{IN}, V_{LDOIN}, V_{DDQSNS}, S3, S5$)		-0.3~6	V
Power Ground Output for the V_{TT} Output	P_{GND}	-0.3~0.3	V
Output Voltage(V_{TT}, V_{TTREF})	V_{TT}, V_{TTREF}	-0.3~ $V_{LDOIN}+0.3$	V
Junction Temperature	T_J	160	°C
Storage Temperature	T_{STG}	-55 ~ +160	°C

Note: Absolute maximum ratings are those values beyond which the device could be permanently damaged.
Absolute maximum ratings are stress ratings only and functional device operation is not implied.

■ RECOMMENDED OPERATING CONDITIONS (Note1, 2)

PARAMETER	SYMBOL	MIN	TYP	MAX	UNIT
Input Voltage	V_{IN}	3		5.5	V
STR and Shutdown Voltage	$S3, S5$	-0.1		5.5	V
V_{DDQ} Sense Input	V_{DDQSNS}	1.3		3.6	V
Power Supply for the V_{TT} and V_{TTREF} Output Stage	V_{LDOIN}	1.2		3.6	V
Power Ground Output for the V_{TT} Output	P_{GND}	-0.1		0.1	V
Operating Temperature	T_A	-40		85	°C

Note: 1. All voltage values are with respect to the network ground terminal unless otherwise noted.

2. Please always keep $V_{LDOIN}, V_{TTSNS}, V_{DDQSNS}, S3, S5$ lower than V_{IN} on operation.

■ ELECTRICAL CHARACTERISTICS

($V_{IN}=5V, V_{LDOIN}=V_{DDQSNS}=2.5V, T_A=25^\circ C$. Unless otherwise specified)

PARAMETER	SYMBOL	TEST CONDITIONS	MIN	TYP	MAX	UNIT
Current of V_{IN}	I_{VIN}	$S5=Hi, S3=Hi$, no load(Normal)	0.5	0.8	2	mA
	I_{VINSTB}	$S5=Hi, S3=Lo$, no load(Standby)		110	200	uA
	$I_{VINSNDN}$	$S5=Lo, S3=Lo$, no load(Shutdown)			1	uA
Current of V_{LDOIN}	I_{VLDOIN}	$S5=Hi, S3=Hi$, no load(Normal)		0.03	2	mA
	$I_{VLDOINSTB}$	$S5=Hi, S3=Lo$, no load(Standby)		0.1	10	uA
	$I_{VLDOINSDN}$	$S5=Lo, S3=Lo$, no load(Shutdown)		0.1	1	uA
Input Impedance of V_{DDQSNS}	$Z_{VDDQSNS}$	$S5=Hi, S3=Hi$		200		kΩ
Input Current of V_{TTSNS}	I_{VTTSNS}	$S5=Hi, S3=Hi$		0.3	1	uA
Output Voltage of V_{TT}	V_{TT}	DDR1($V_{LDOIN}=V_{DDQSNS}=2.5V$)		1.25		V
		DDR2($V_{LDOIN}=V_{DDQSNS}=1.8V$)		0.9		
		DDR3($V_{LDOIN}=V_{DDQSNS}=1.5V$)		0.75		
Load Regulation of V_{TT} ($V_{TTREF}-V_{TT}$)	$V_{OS}V_{TT}$	$I_{VTT}=0$	-20		20	mV
		$ I_{VTT} < 1.5A$	-30		30	
		$ I_{VTT} < 3A$	-40		40	
Source Current Limit of V_{TT}	$I_{VTTCLSRC}$	$V_{TT}=V_{DDQSNS}/2*0.95, PGOOD=HI$	3	4		A
		$V_{TT}=0$	1.5	2		
Sink Current Limit of V_{TT}	$I_{VTTCLSNK}$	$V_{TT}=V_{DDQSNS}/2*1.05, PGOOD=HI$	3	4		A
		$V_{TT}=V_{DDQSNS}$	1.5	2		
Leakage Current of V_{TT}	I_{VTTLK}	$S5=Hi, S3=Lo$		0.01		uA
Discharge Current of V_{TT}	I_{VTTDIS}	$S5=Lo, V_{DDQSNS}=0V, V_{TT}=0.5V$	10	20		mA
Output Voltage of V_{TTREF}	V_{TTREF}	DDR1($V_{LDOIN}=V_{DDQSNS}=2.5V$)		1.25		V
		DDR2($V_{LDOIN}=V_{DDQSNS}=1.8V$)		0.9		
		DDR3($V_{LDOIN}=V_{DDQSNS}=1.5V$)		0.75		
Load Regulation of V_{TTREF}	ΔV_{TTREF}	$ I_{VTTREF} < 10mA$	-20		20	mV
High Level Input Voltage	V_{IH}	$S3 \& S5$ pin	1.6			V
Low Level Input Voltage	V_{IL}	$S3 \& S5$ pin			1	
Logic Input Leakage Current	I_{ILEAK}	$S3 \& S5$ pin	-1		1	uA
Thermal Shutdown Temperature	T_{SD}	$V_{IN}=3V\sim 5.5V$		160		°C
Thermal Shutdown Hysteresis	ΔT_{SD}	$V_{IN}=3V\sim 5.5V$		20		

■ TYPICAL APPLICATIONS CIRCUIT

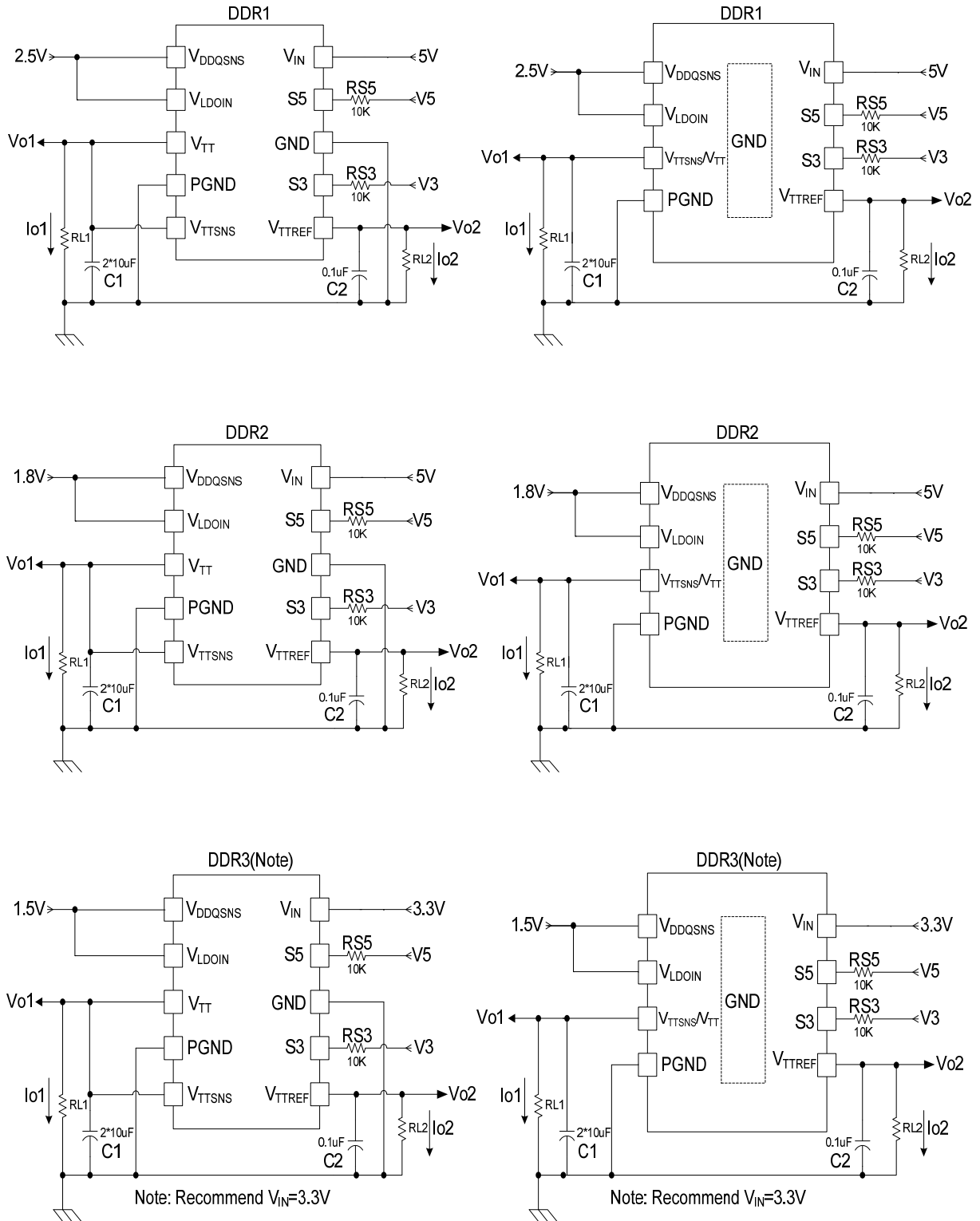

■ TYPICAL CHARACTERISTICS

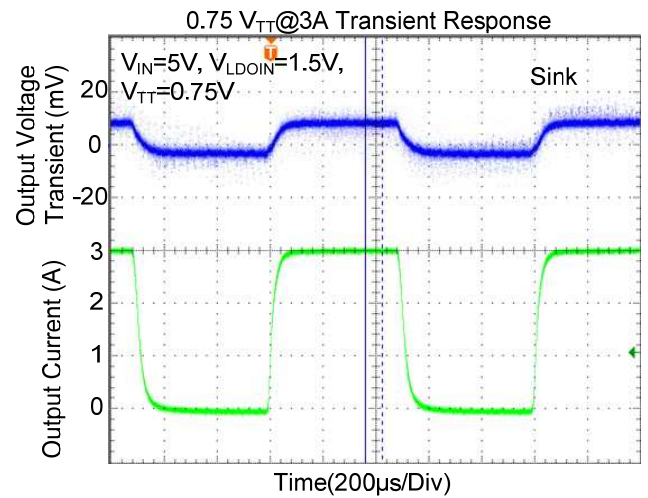
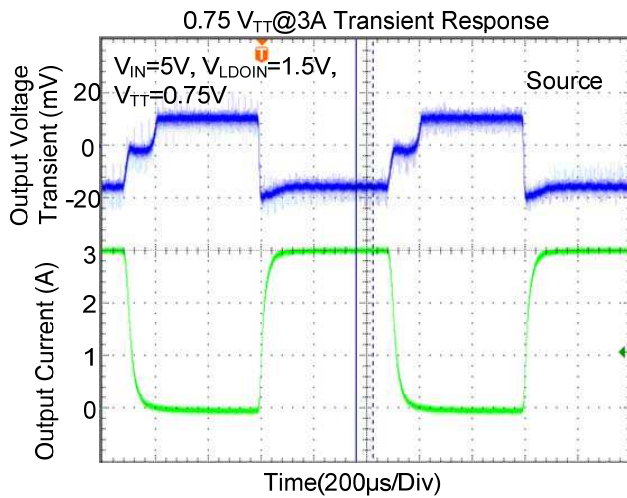
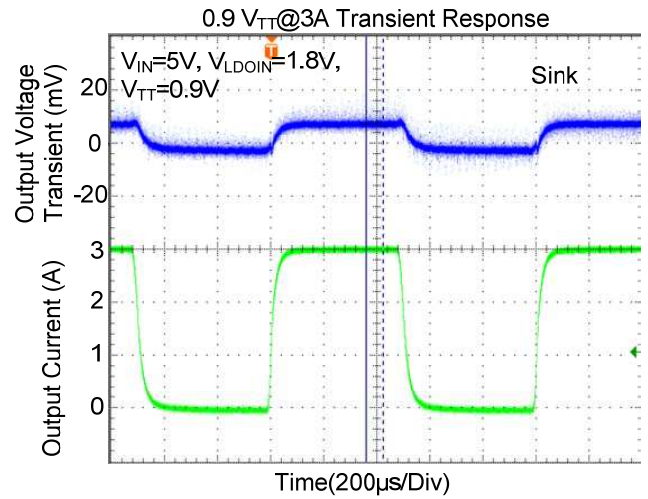
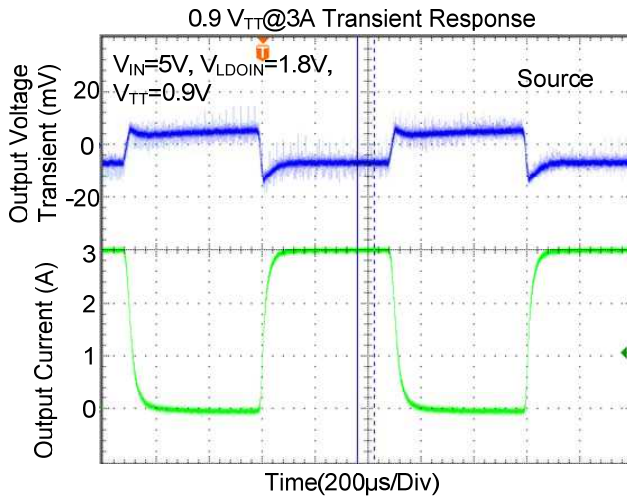
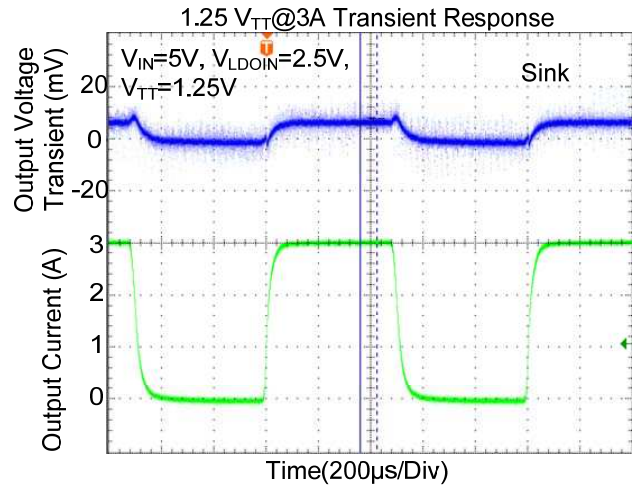
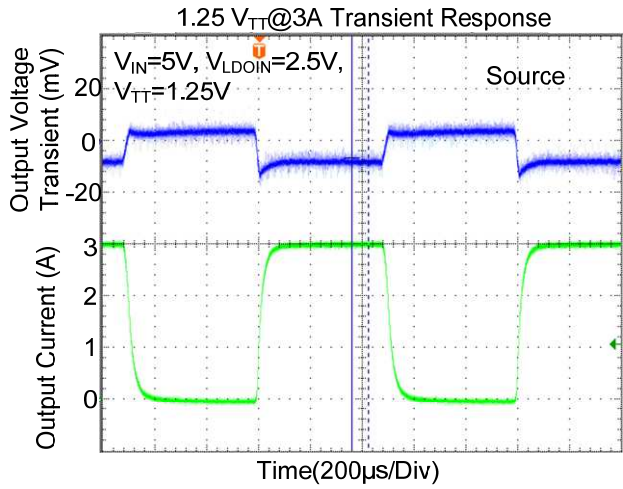

■ TYPICAL CHARACTERISTICS(Cont.)

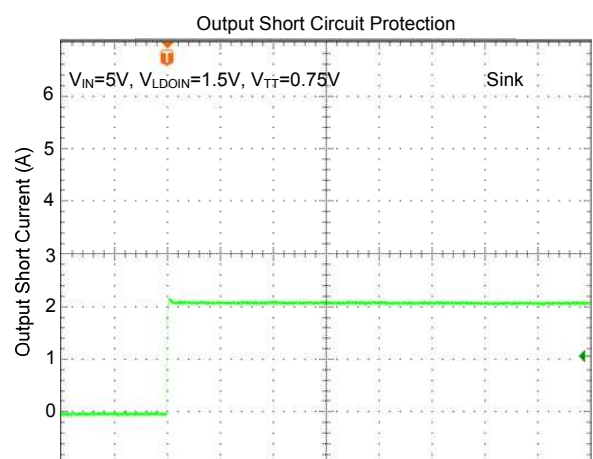
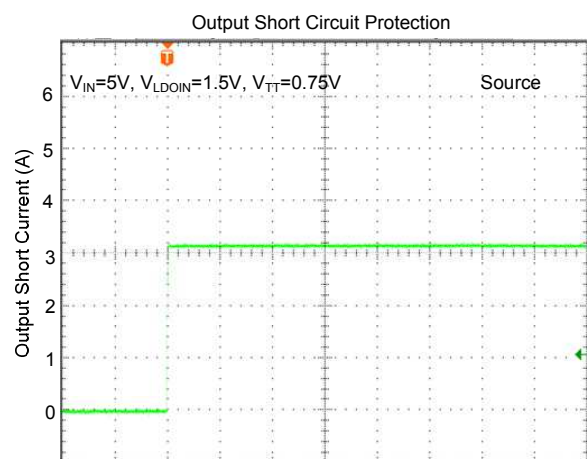
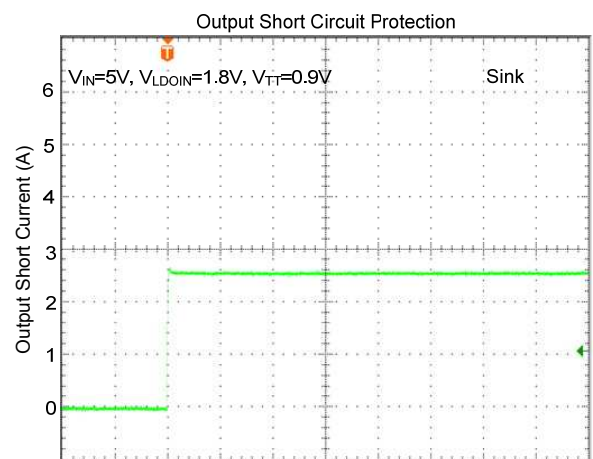
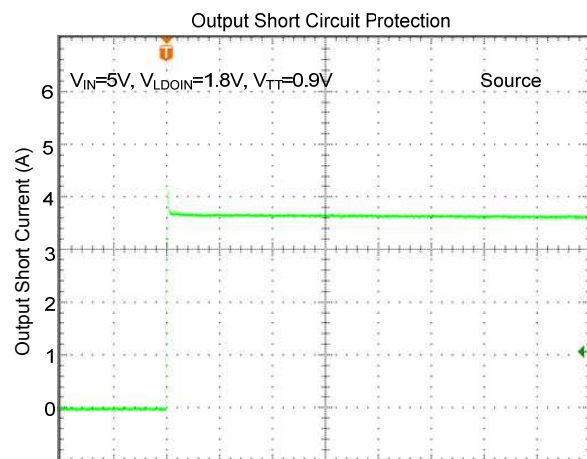
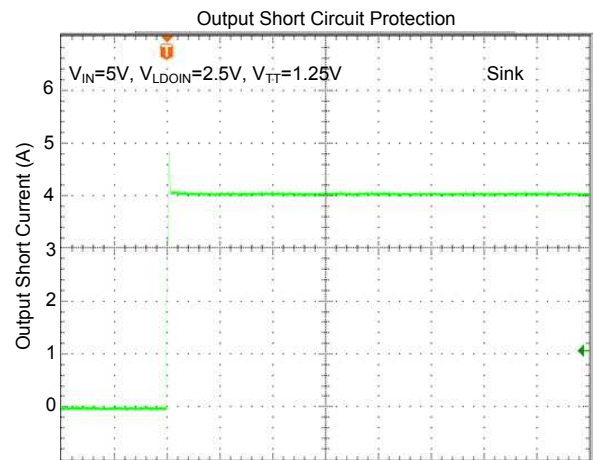
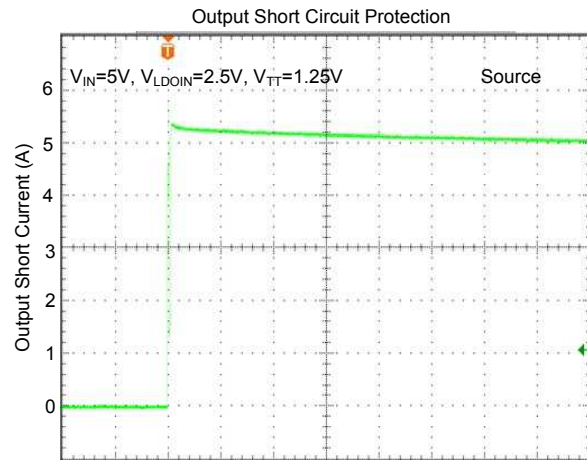

■ TYPICAL CHARACTERISTICS(Cont.)

Start Up Waveforms S5 Low to High

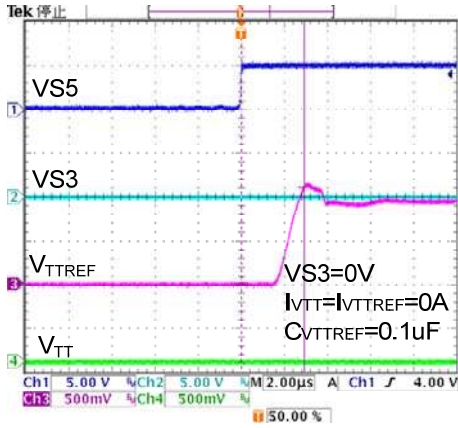

Start Up Waveforms S5 Low to High

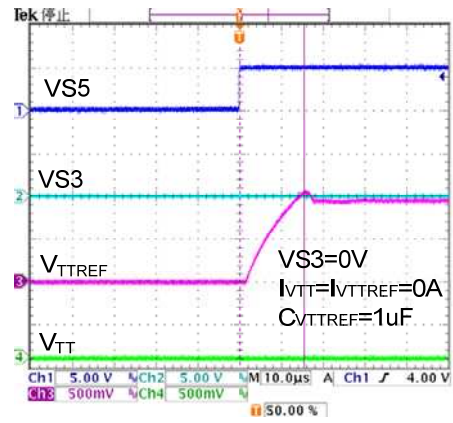

Start Up Waveforms S3 Low to High

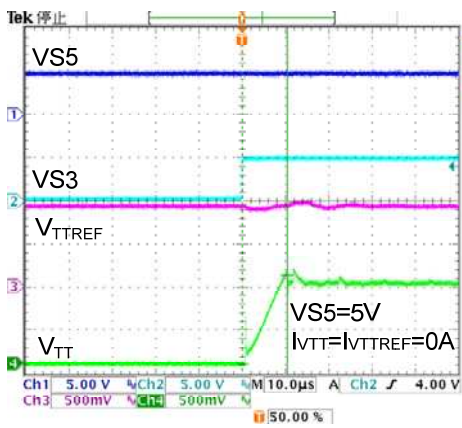

Shutdown Waveforms S3 High to Low

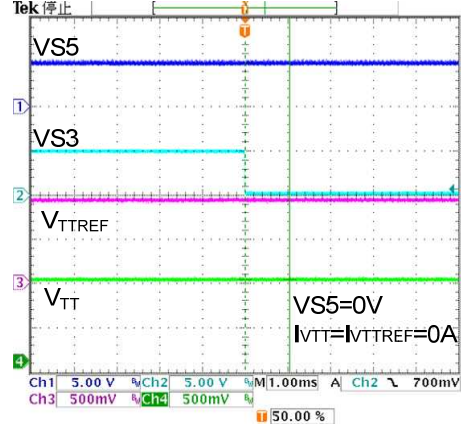

Shutdown Waveforms S3&S5 High to Low

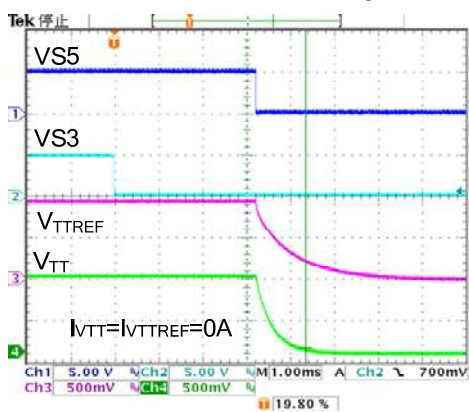

UTC assumes no responsibility for equipment failures that result from using products at values that exceed, even momentarily, rated values (such as maximum ratings, operating condition ranges, or other parameters) listed in products specifications of any and all UTC products described or contained herein. UTC products are not designed for use in life support appliances, devices or systems where malfunction of these products can be reasonably expected to result in personal injury. Reproduction in whole or in part is prohibited without the prior written consent of the copyright owner. The information presented in this document does not form part of any quotation or contract, is believed to be accurate and reliable and may be changed without notice.