



3513

CMOS IC

PC POWER SUPPLY SUPERVISOR

DESCRIPTION

The UTC 3513 is designed to provide protection circuits, power good output (PGO) indicator, fault protection output (FPOB) and a PSONB control for PC switching power supply systems.

The protection circuits include over voltage protection (OVP), under voltage protection (UVP) and over current protection(OCP) monitoring for 3.3V, 5V and two 12V.

When 3.3V, 5V or 12V voltage is decreasing to 2.68V, 4.3V and 9.9V respectively, the under voltage protection (UVP) function will be enabled. FPO will be set to high to turn off the PWM controller IC. Toggling the PSONB from low to high will reset the fault protection latch.

The voltage difference across external current shunt is used for OCP functions. An external resistor can be used to adjust protection threshold.

The power supply is turned on after 38mS delay time when PSONB signal is set from high to low. To turn off power supply, PSONB signal is set from low to high with the delay time 38mS. The PGI circuitry provides a power-down warning signal for PGO. When PGI input is lower than the internal 1.20V reference voltage, PGO signal is pulled low.

The device is available in two versions: UTC 3513E/3513F. Specially, fan control function is available in OTP/FC pin of UTC 3513F.

FEATURES

- * OVP/UVP monitors 3.3V, 5V, 12V input voltage level.
- * OCP monitors I_{S33} , I_{S5} , I_{S12} input current sense.
- * Fault protection output (FPOB) with Open Drain Output stage.
- * Power good output (PGO) with Open Drain Output stage.
- * 38ms de-bounce time for PSONB input signal.
- * 300ms time delay from PGI to PGO.
- * 2.4ms time delay for PSONB to turn off FPOB.

ORDERING INFORMATION

| Ordering Number | | Package | Packing |
|-----------------|--------------|---------|-----------|
| Lead Free | Halogen Free | | |
| 3513EL-D16-T | 3513EG-D16-T | DIP-16 | Tube |
| 3513EL-S16-R | 3513EG-S16-R | SOP-16 | Tape Reel |
| 3513EL-S16-T | 3513EG-S16-T | SOP-16 | Tube |
| 3513FL-D16-T | 3513FG-D16-T | DIP-16 | Tube |
| 3513FL-S16-R | 3513FG-S16-R | SOP-16 | Tape Reel |
| 3513FL-S16-T | 3513FG-S16-T | SOP-16 | Tube |

| | |
|---|---|
| <p>3513EL-D16-T</p> <p>(1)Packing Type (2)Package Type (3)Lead Free</p> | <p>(1) R: Tape Reel, T: Tube (2) D16: DIP-16, S16: SOP-16 (3) G: Halogen Free, L: Lead Free</p> |
|---|---|

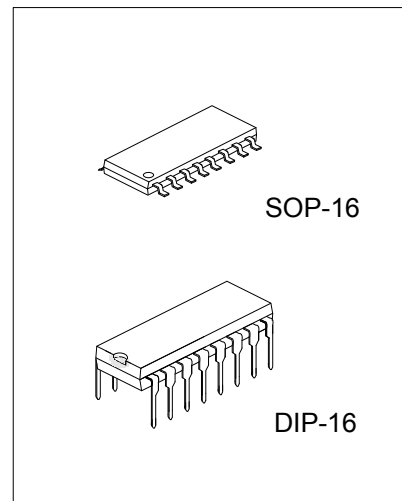

■ PIN ASSIGNMENT

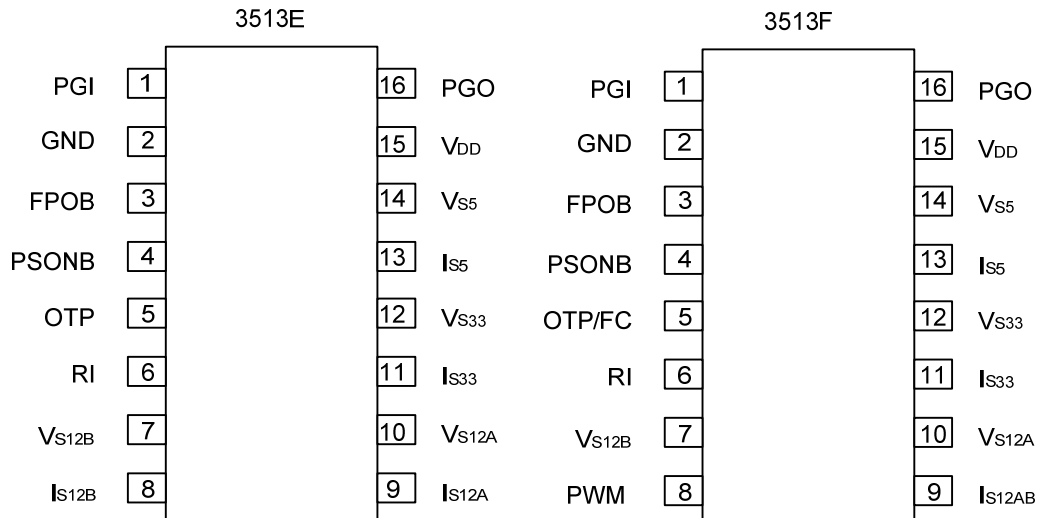

■ PIN DESCRIPTIONS

| PIN NO | PIN NAME | TYPE | DESCRIPTION |
|--------|------------------|--------|--|
| 1 | PGI | Input | Power Good Input. For ATX SMPS, it detects AC line voltage through the main transformer. |
| 2 | GND | Supply | Ground |
| 3 | FPOB | Output | Fault Protection Output. Output signal to control the primary PWM IC through an opto-coupler. When FPOB is low, the PWM IC is enabled. |
| 4 | PSONB | Input | Remote On/Off logic input from CPU or main-board. The power supply will be turned on/off after 38mS delay. |
| 5 | OTP/FC | Input | Over temperature protection/Fan speed control |
| 6 | RI | Input | Reference setting. One external resistor Ri connected between RI and GND pin will determine a reference current, $I_{REF} = 1.20/R_i$, for OCP programming. |
| 7 | V_{S12B} | Input | 12V over/under voltage protection. |
| 8 | I_{S12B}^* | Input | 12V over current protection. |
| 8 | PWM** | Output | Pulse width modulation. |
| 9 | I_{S12A}^* | Input | 12V over current protection. |
| 9 | I_{S12AB}^{**} | Input | 12V over current protection. |
| 10 | V_{S12A} | Input | 12V over/under voltage protection. |
| 11 | I_{S33} | Input | 3.3V over current protection |
| 12 | V_{S33} | Input | 3.3V over/under voltage protection |
| 13 | I_{S5} | Input | 5V over current protection. |
| 14 | V_{S5} | Input | 5V over/under voltage protection. |
| 15 | V_{DD} | Supply | Power supply. |
| 16 | PGO | Output | Power good logic output, 0 or 1(open-drain). Power good=1 means that the power supply is good for operation. The power good delay is 300mS. |

* 3513E only

** 3513F only

■ FUNCTION DESCRIPTION(1)

| ORDERING | OTP low level | OTP high level | FC/PWM | T(PSONB ON)/ T(PSONB OFF) | tg2 |
|----------|---------------|----------------|--------|------------------------------|------|
| 3513E | 2.45V | 3.25V | X | 38ms | 73μs |
| 3513F | 2.45V | 3.25V | ○ | 38ms | 73μs |

■ FUNCTION DESCRIPTION(2)

| PGI | PSONB | UV&OC Protection | OV Protection | FPOB | PGO |
|----------|-------|------------------|---------------|------|-----|
| PGI<1.2V | L | No | No | L | L |
| PGI<1.2V | L | No | Yes | H | L |
| PGI<1.2V | L | Yes | No | L | L |
| PGI<1.2V | L | Yes | Yes | H | L |
| PGI>1.2V | L | No | No | L | H |
| PGI>1.2V | L | No | Yes | H | L |
| PGI>1.2V | L | Yes | No | H | L |
| PGI>1.2V | L | Yes | Yes | H | L |
| X | H | X | X | H | L |

Note: FPOB=L means: fault is not latched. FPOB=H means: fault is latched

PGO=L means: fault. PGO=H means: No fault

X=do not care

■ BLOCK DIAGRAM

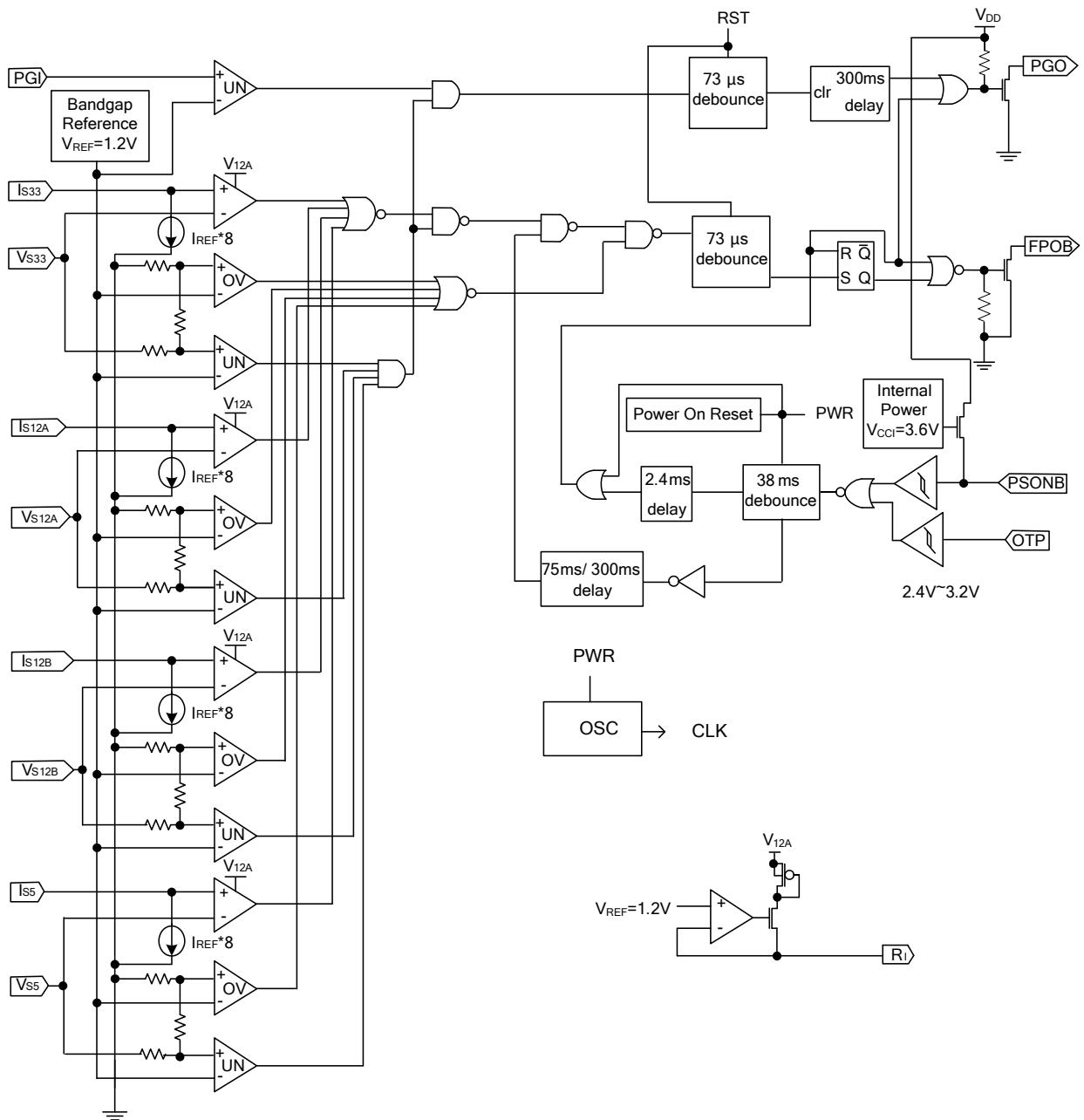

Fig. 1 3513E

■ BLOCK DIAGRAM(Cont.)

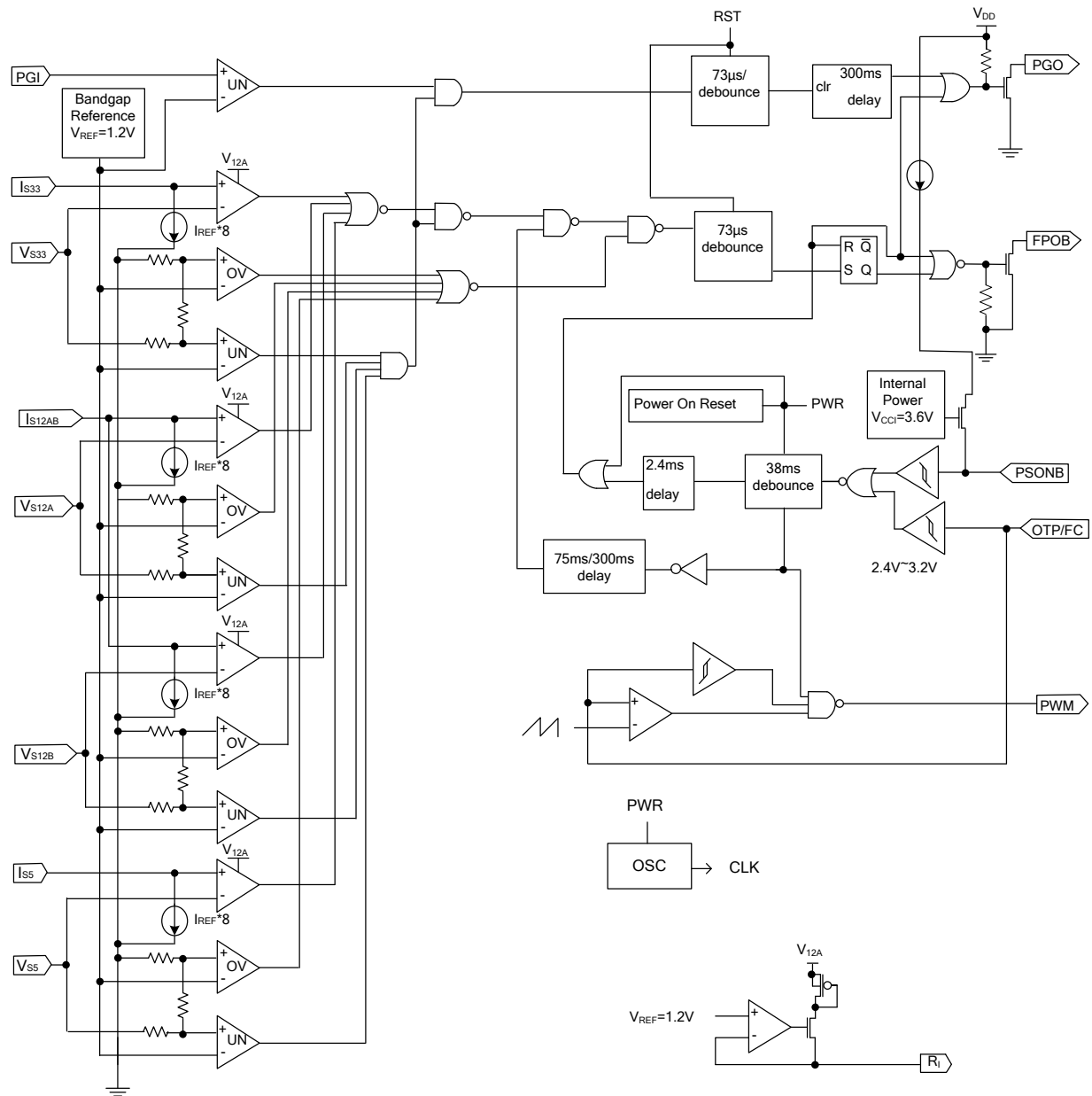

Fig. 2 3513F

■ ABSOLUTE MAXIMUM RATINGS

| PARAMETER | | SYMBOL | RATINGS | UNIT |
|-----------------------|---------------------------------------|-----------|----------------------|------|
| Supply Voltage | | V_{DD} | -0.3 ~ 16 | V |
| Input Voltage | V_{S5}, V_{S33} | V_{IN} | -0.3 ~ 7 | V |
| | V_{S12A}, V_{S12B} | | -0.3 ~ 16 | V |
| | $I_{S12A}, I_{S12B}, I_{S5}, I_{S33}$ | | -0.3 ~ $V_{12A}+0.3$ | V |
| | PSONB, PGI, OTP | | -0.3 ~ 7 | V |
| Output Voltage | FPOB | V_{OUT} | -0.3 ~ $V_{DD}+0.3$ | V |
| | PGO | | -0.3 ~ $V_{DD}+0.3$ | V |
| Operating Temperature | | T_{OPR} | -40 ~ +125 | °C |
| Storage Temperature | | T_{STG} | -55 ~ +150 | °C |

Note 1. Absolute maximum ratings are those values beyond which the device could be permanently damaged.

Absolute maximum ratings are stress ratings only and functional device operation is not implied.

2. Stress above those listed may cause permanent damage to the devices.

■ RECOMMENDED OPERATING CONDITIONS

| PARAMETER | | SYMBOL | MIN | TYP | MAX | UNIT |
|---|---------------------------------------|---------------|-----|-----|-----|------|
| Supply Voltage | | V_{DD} | 4 | 12 | 15 | V |
| Input Voltage | V_{S5}, V_{S33} | V_{IN} | | | 7 | V |
| | V_{S12A}, V_{S12B} | | | | 15 | V |
| | $I_{S12A}, I_{S12B}, I_{S5}, I_{S33}$ | | | | 15 | V |
| | PSONB, PGI, OTP | | | | 7 | V |
| Output Voltage | FPOB | V_{OUT} | | | 7 | V |
| | PGO | | | | 7 | V |
| Output Sink Current | FPOB | $I_{O(SINK)}$ | | | 30 | mA |
| | PGO | | | | 10 | mA |
| RI Output Current | | $I_{O(RI)}$ | 10 | | 65 | uA |
| Supply Voltage Rising Time (V_{DD}) | | t_R | 1 | | | ms |

■ ELECTRICAL CHARACTERISTICS ($T_A=25^{\circ}\text{C}$, $V_{DD}=5\text{V}$, $V_{12A}=12\text{V}$)

| PARAMETER | SYMBOL | TEST CONDITIONS | MIN | TYP | MAX | UNIT |
|---------------------------------|--------------------|--------------------------|------|------|------|------|
| OVER VOLTAGE DETECTION | | | | | | |
| Over Voltage Threshold | V_{12A}, V_{12B} | | 13.2 | 13.8 | 14.4 | V |
| | V_5 | | 5.7 | 5.95 | 6.2 | V |
| | V_{33} | | 3.7 | 3.9 | 4.1 | V |
| Low Level Output Voltage (FPOB) | V_{OL} | @ $I_{SINK}=10\text{mA}$ | | | 0.3 | V |
| | | @ $I_{SINK}=30\text{mA}$ | | | 0.7 | |
| Output Leakage Current (FPOB) | I_{LEAK} | @ $V_{(FPOB)}=5\text{V}$ | | | 5 | uA |
| PSONB | | | | | | |
| High-Level Input Voltage | V_{IH} | | 2 | | | V |
| Low-Level Input Voltage | V_{IL} | | | | 0.8 | V |
| Input Pull-up Current | I_{IN} | @ PSONB=0V | | 100 | | uA |

■ ELECTRICAL CHARACTERISTICS (Cont.)

| PARAMETER | SYMBOL | TEST CONDITIONS | MIN | TYP | MAX | UNIT |
|-------------------------------------|--------------------|-------------------------|---------------|------|------|---------|
| PGI AND PGO | | | | | | |
| Under Voltage Threshold | V_{12A}, V_{12B} | | 9.5 | 9.90 | 10.5 | V |
| | V_5 | | 4.15 | 4.30 | 4.45 | V |
| | V_{33} | | 2.54 | 2.68 | 2.82 | V |
| Input Threshold Voltage (PGI) | $V_{I(THD)}$ | | 1.16 | 1.20 | 1.24 | V |
| Low Level Output Voltage (PGO) | V_{OL} | @ $I_{SINK}=10mA$ | | | 0.4 | V |
| Output Leakage current (PGO) | I_{LEAK} | @ PGO=5V | | | 5 | μA |
| OTP/FC | | | | | | |
| High-Level Input Voltage (OTP) | V_{IH} | 3513E/3513F | 3.10 | 3.25 | 3.40 | V |
| Low-Level Input Voltage (OTP) | V_{IL} | | 2.30 | 2.45 | 2.60 | V |
| Start-up Voltage (FC) | | | 0.7 | 0.8 | 0.9 | V |
| Stop Voltage (FC) | | | 0.55 | 0.65 | 0.75 | V |
| PWM | | | | | | |
| High Level Output Voltage | V_{OH} | @ $I_{SOURCE}=4.5mA$ | $V_{12A}-0.4$ | | | V |
| Low Level Output Voltage | V_{OL} | @ $I_{SINK}=4.5mA$ | | | 0.4 | V |
| Output Leakage Current | I_{LEAK} | | | | 5 | μA |
| PWM Frequency | f_{PWM} | | 28 | 35 | 42 | KHz |
| SWITCHING CHARACTERISTICS | | | | | | |
| PSONB ON (PSONB Low to FPOB Low) | $T_{(PSONB ON)}$ | @ $V_{DD}=5V$ | 32 | 38 | 62 | ms |
| PSONB OFF (PSONB Hi to PGO Low) | $T_{(PSONB OFF)}$ | @ $V_{DD}=5V$ | 32 | 38 | 62 | ms |
| PGI to PGO Delay Time | T_{PG} | @ $V_{DD}=5V$ | 200 | 300 | 490 | ms |
| Timing PGO Low to FPO high | T_{PSOFF} | @ $V_{DD}=5V$ | 2.0 | 2.4 | 4 | ms |
| UVD/OCD turn on delay Time | T_{UVP1} | @ FPOB=Low & PGI > 1.2V | 65 | 75 | 122 | ms |
| | T_{UVP2} | @ FPOB=Low & PGI < 1.2V | 260 | 300 | 488 | ms |
| Noise Deglitch Time | t_{G1} | | 63 | 75 | 120 | μs |
| Noise Deglitch Time for Latch | t_{G2} | | 63 | 75 | 120 | μs |
| TOTAL DEVICE | | | | | | |
| Low Voltage | V_{DD} | | | 3.6 | | V |
| Supply Current | I_{DD} | @ PSONB=5V | | | 1 | mA |

APPLICATION CIRCUIT

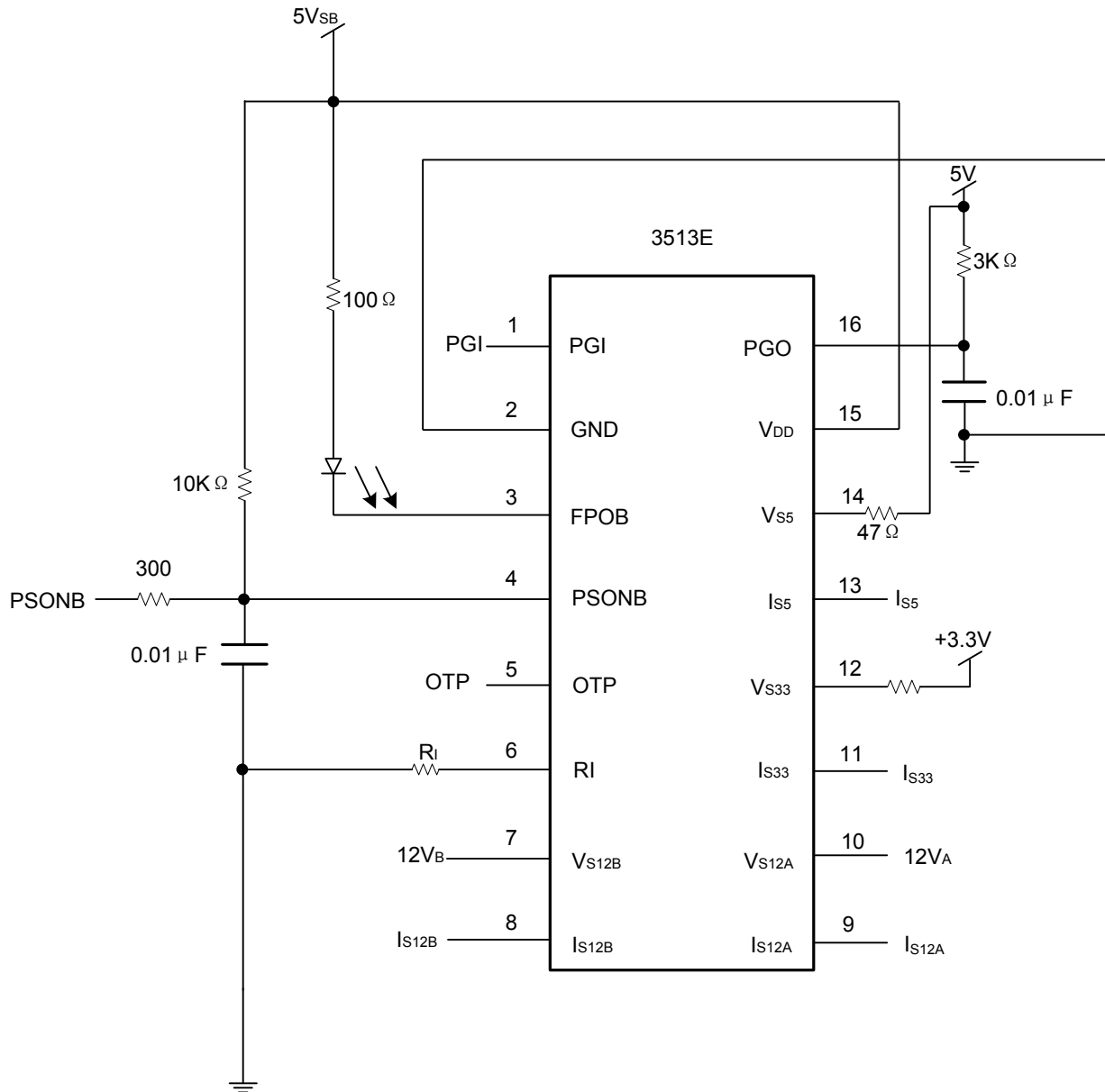

■ APPLICATION CIRCUIT(Cont.)

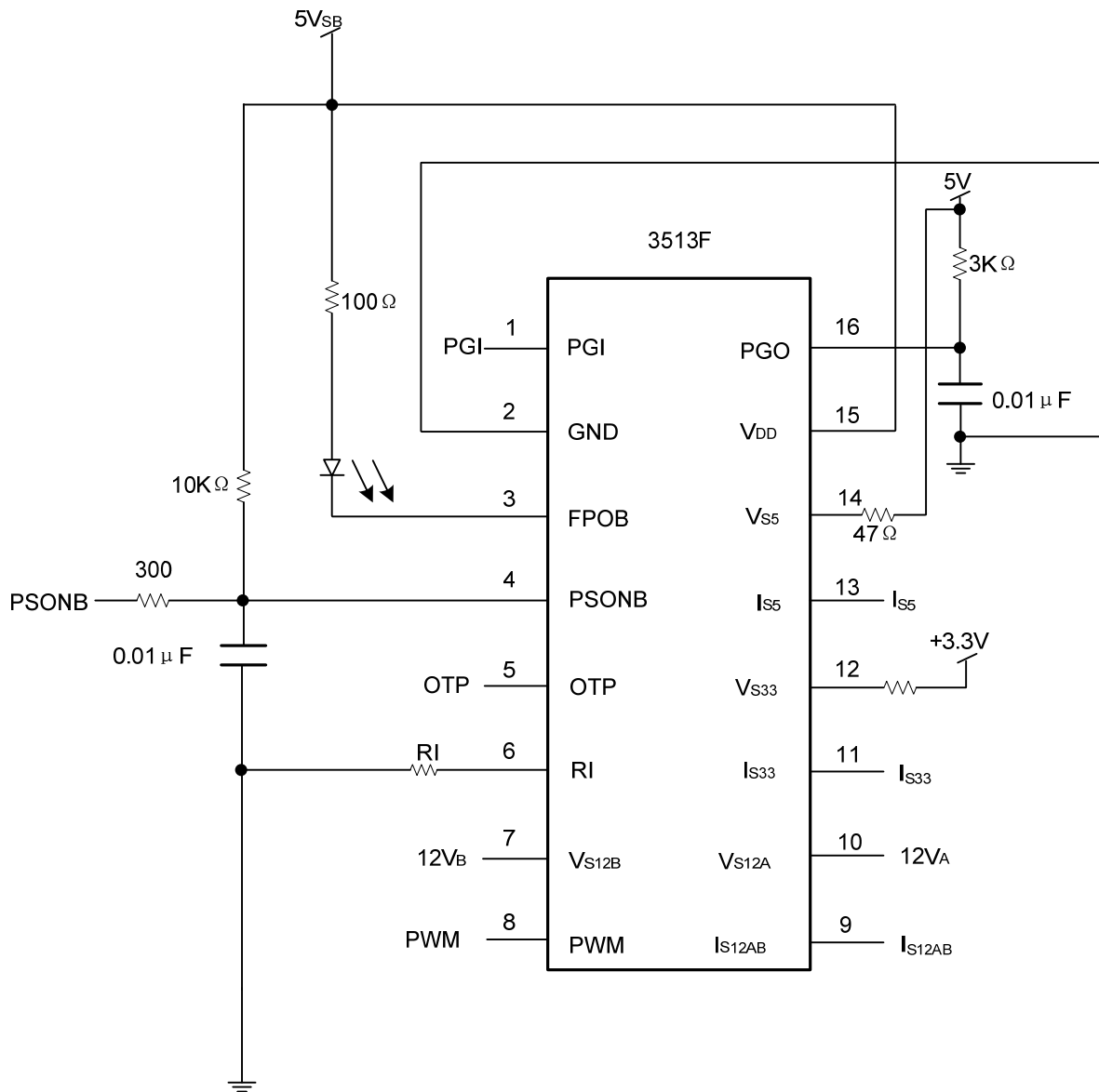

■ TYPICAL TIMMING DIAGRAM

1) PGI (UNDER-VOLTAGE):

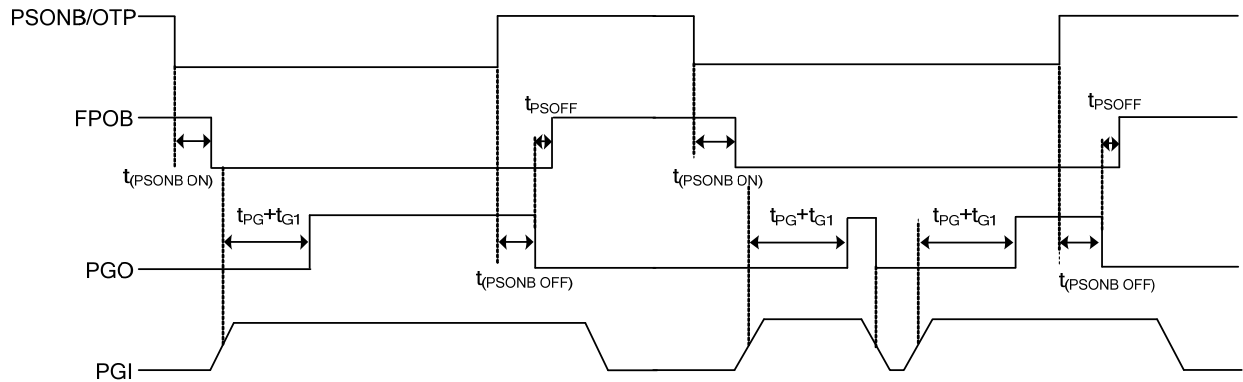

2) V_{33} , V_5 , V_{12A} , V_{12B} (UNDER-VOLTAGE) or I_{S33} , I_{S5} , I_{S12A} , I_{S12B} (OVER-CURRENT):

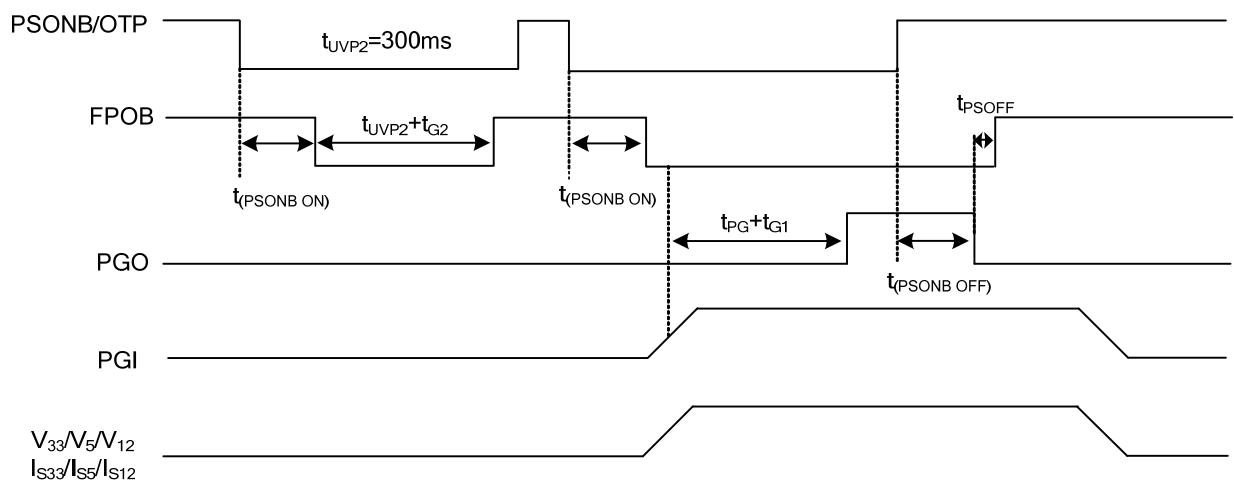
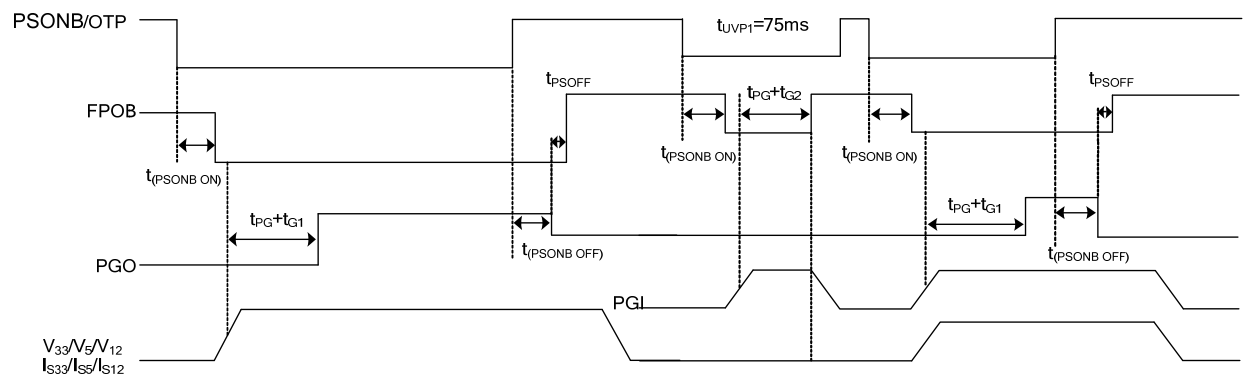

■ TYPICAL TIMMING DIAGRAM

3) V_{33} , V_5 , V_{12A} , V_{12B} (OVER-VOLTAGE).

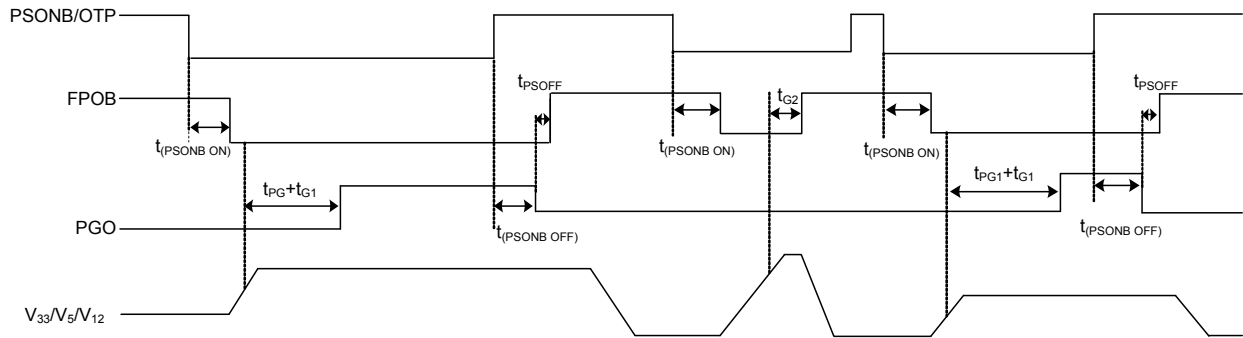

4) OTP/FC, PWM, FPOB:

(at $V_{DD}=5V$, $PSONB=0V$, V_{12A} , $V_{12B} =12V$, $V_5=5V$, $V_{33}=3.3V$)

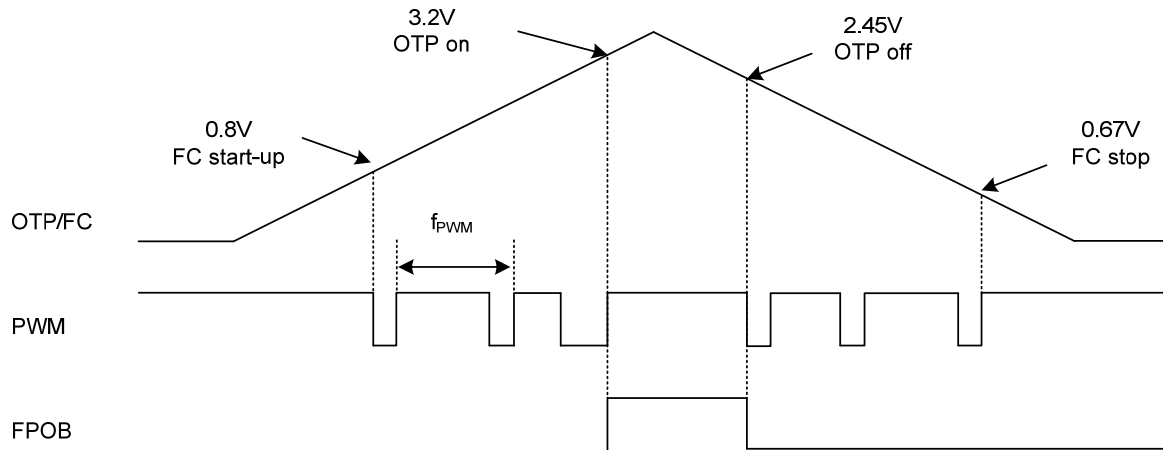

UTC assumes no responsibility for equipment failures that result from using products at values that exceed, even momentarily, rated values (such as maximum ratings, operating condition ranges, or other parameters) listed in products specifications of any and all UTC products described or contained herein. UTC products are not designed for use in life support appliances, devices or systems where malfunction of these products can be reasonably expected to result in personal injury. Reproduction in whole or in part is prohibited without the prior written consent of the copyright owner. The information presented in this document does not form part of any quotation or contract, is believed to be accurate and reliable and may be changed without notice.