



3510

CMOS IC

PC POWER SUPPLY SUPERVISORS

DESCRIPTION

The UTC 3510 is designed to provide protection circuits, power good output (PGO) indicator, fault protection output (FPO) and a PSON control for PC switching power supply systems.

The protection circuits include over voltage protection (OVP) monitoring for 3.3V, 5V and 12V (12V via V_{DD} pin) and under voltage protection(UVP) monitoring for 3.3V and 5V. When an OV or UV event arose and is detected, the power good output (PGO) goes low and the FPO will be set to high. The protection latch can be reset by setting PSON to high. UVP function is enabled 75ms after PSON is set low and de-bounced. Besides, there is a 2.3ms delay with 38ms de-bounce at turn off but no delay during turn on.

When OVP and UVP detected the right voltage level, a PGO signal will be issued.

FEATURES

- * Over Voltage Protection and Lock Out for 3V, 5V and 12V.
- * Under Voltage Protection and Lock Out for 3.3V and 5V.
- * Open Drain Output for PGO and FPO pin.
- * 300ms delay for PGO.
- * 75ms delay for 3.3V and 5V short-circuit turn-on protection.
- * 2.3ms PSON control to FPO turn-off delay.
- * 38ms PSON control de-bounce.
- * 73us width noise deglitches.
- * Wide supply voltage range from 4V ~15V.

ORDERING INFORMATION

Ordering Number		Package	Packing
Lead Free	Halogen Free		
3510L-D08-T	3510G-D08-T	DIP-8	Tube
3510L-S08-R	3510G-S08-R	SOP-8	Tape Reel
3510L-S08-T	3510G-S08-T	SOP-8	Tube

<p>3510L-D08-T</p> <p>(1)Packing Type (2)Package Type (3)Lead Free</p>	<p>(1) R: Tape Reel, T: Tube (2) D08: DIP-8, S08: SOP-8 (3) G: Halogen Free, L: Lead Free</p>
--------------------------------------------------------------------------------	-------------------------------------------------------------------------------------------------------

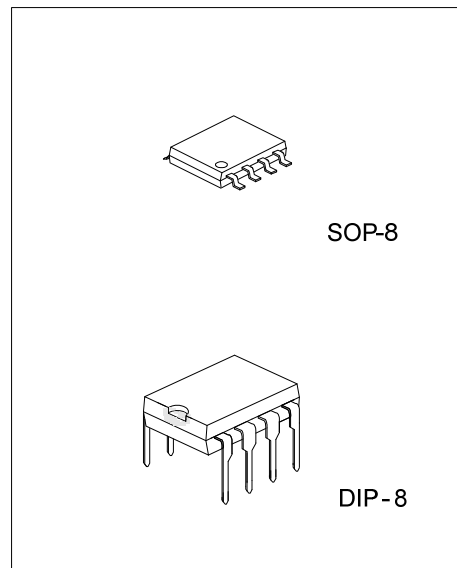

■ PIN CONFIGURATION

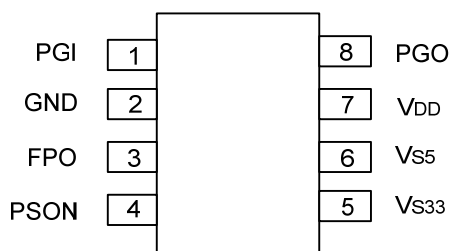

■ PIN DESCRIPTION

PIN No.	PIN NAME	TYPE	DESCRIPTION
1	PGI	I	Power good input
2	GND		Ground
3	FPO	O	Fault protection output(invert), open drain output stage
4	PSON	I	ON/OFF control
5	V _{S33}	I	3.3V over/under-voltage protection
6	V _{S5}	I	5V over/under-voltage protection
7	V _{DD}	I	Supply voltage/12V over-voltage protection input pin
8	PGO	O	Power good output, open drain output stage

■ BLOCK DIAGRAM

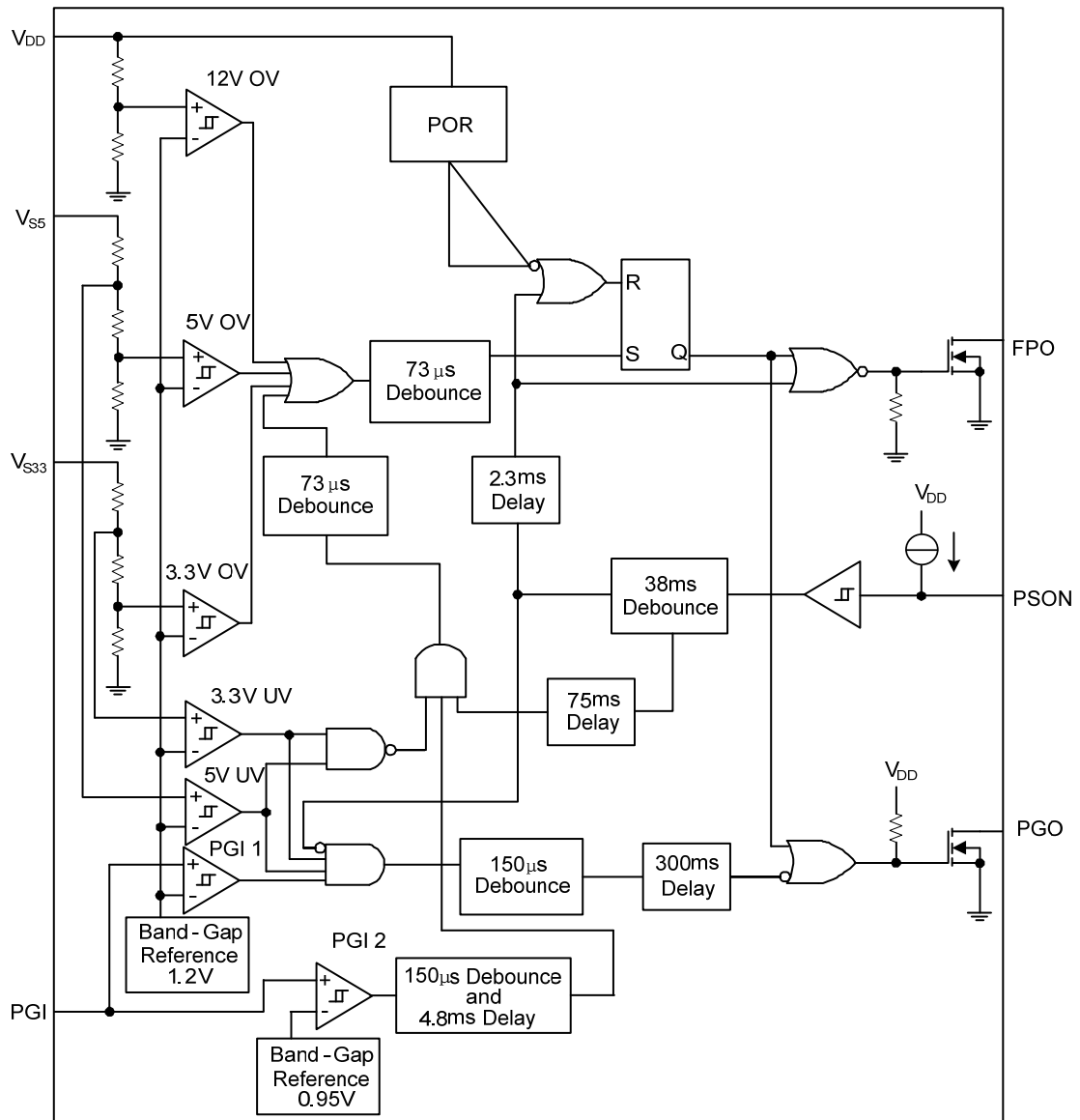

■ ABSOLUTE MAXIMUM RATINGS

PARAMETER		SYMBOL	RATINGS	UNIT
Supply Voltage		V_{DD}	16	V
Output Voltage	FPO	V_{OUT}	16	V
	PGO		8	
All Other Pins			-0.3 ~ 16	V
Power Dissipation ($T_A \leq 25^\circ\text{C}$)	DIP-8	P_D	1092	mW
	SOP-8		730	
Operating Temperature		T_{OPR}	-20 ~ +85	$^\circ\text{C}$
Storage Temperature		T_{STG}	-40 ~ +150	$^\circ\text{C}$

Note: 1. Absolute maximum ratings are stress ratings only and functional device operation is not implied. The device could be damaged beyond Absolute maximum ratings.

2. The device is guaranteed to meet performance specifications within $0^\circ\text{C} \sim +70^\circ\text{C}$ operating temperature range and assured by design from $-20^\circ\text{C} \sim +85^\circ\text{C}$.

■ RECOMMENDED OPERATING CONDITIONS

PARAMETER		SYMBOL	MIN	TYP	MAX	UNIT
Supply Voltage		V_{DD}	4		15	V
Input Voltage	PSON, VS5, VS33	V_{IN}			7	V
	PGI		$V_{DD}+0.3V$	7		
Output Voltage	FPO	V_{OUT}			15	V
	PGO				7	
Output Sink Current	FPO	$I_{O(SINK)}$			20	mA
	PGO				10	
Supply Voltage Rising Time (See Note)			1			ms

Note: V_{DD} rising and falling slew rate must be less than 14V/ms.

■ ELECTRICAL CHARACTERISTICS ($T_A=25^\circ\text{C}$, unless otherwise specified.)

PARAMETER		SYMBOL	TEST CONDITIONS	MIN	TYP	MAX	UNIT
OVER-VOLTAGE PROTECTION							
Over Voltage Threshold		V_{S33}		3.7	3.9	4.1	V
		V_{S5}		5.7	6.1	6.5	
		V_{DD}		13.0	13.8	14.4	
Low-level Output Voltage (FPO)		V_{OL}	$V_{DD} = 5V, I_{O(SINK)} = 20mA$			0.7	V
Leakage Current (FPO)		I_{LEAK}	$V_{(FPO)} = 5V$			5	μA
Noise Deglitch Time OVP			$V_{DD} = 5V$	35	73	110	μS
PGI AND PGO							
Input threshold Voltage	PGI	V_{PG1}		1.1	1.15	1.2	V
		V_{PG2}		0.9	0.95	1	
Under Voltage Threshold	V_{S33}	V_{IT}		2	2.2	2.4	V
	V_{S5}			3.3	3.5	3.7	
Low-level Output Voltage (PGO)		V_{OL}	$V_{DD} = 4V, I_{O(SINK)} = 10mA$			0.4	V
Leakage Current (PGO)		I_{LEAK}	$PGO = 5V$			5	μA
Short-Circuit Protection Delay			3.3V, 5V	49	75	114	ms
Transient Delay time	PGI to PGO	t_{DLY1}	$V_{DD} = 5V$	200	300	450	ms
	PGI to FPO			3.2	4.8	7.2	
Noise Deglitch Time	PGI to PGO		$V_{DD} = 5V$	88	150	225	μs
	PGI to FPO			180	296	445	
	UVP to FPO			82	146	220	

■ ELECTRICAL CHARACTERISTICS(Cont.)

PARAMETER	SYMBOL	TEST CONDITIONS	MIN	TYP	MAX	UNIT
PSON CONTROL						
Input Voltage	High-level	V_{IH}		2.4		V
	Low-level	V_{IL}			1.2	V
Input Pullup Current	I_{IN}	PSON = 0 V		120		μ A
Debounce Time (PSON)	t_B	$V_{DD} = 5$ V	24	38	57	ms
Transient Delay Time (PSON to FPO)	t_{DLY2}	$V_{DD} = 5$ V	$t_B+1.1$	$t_B+2.3$	t_B+4	ms
TOTAL DEVICE						
Supply Current	I_{DD}	PSON =5V			1	mA

■ TIMING DIAGRAM

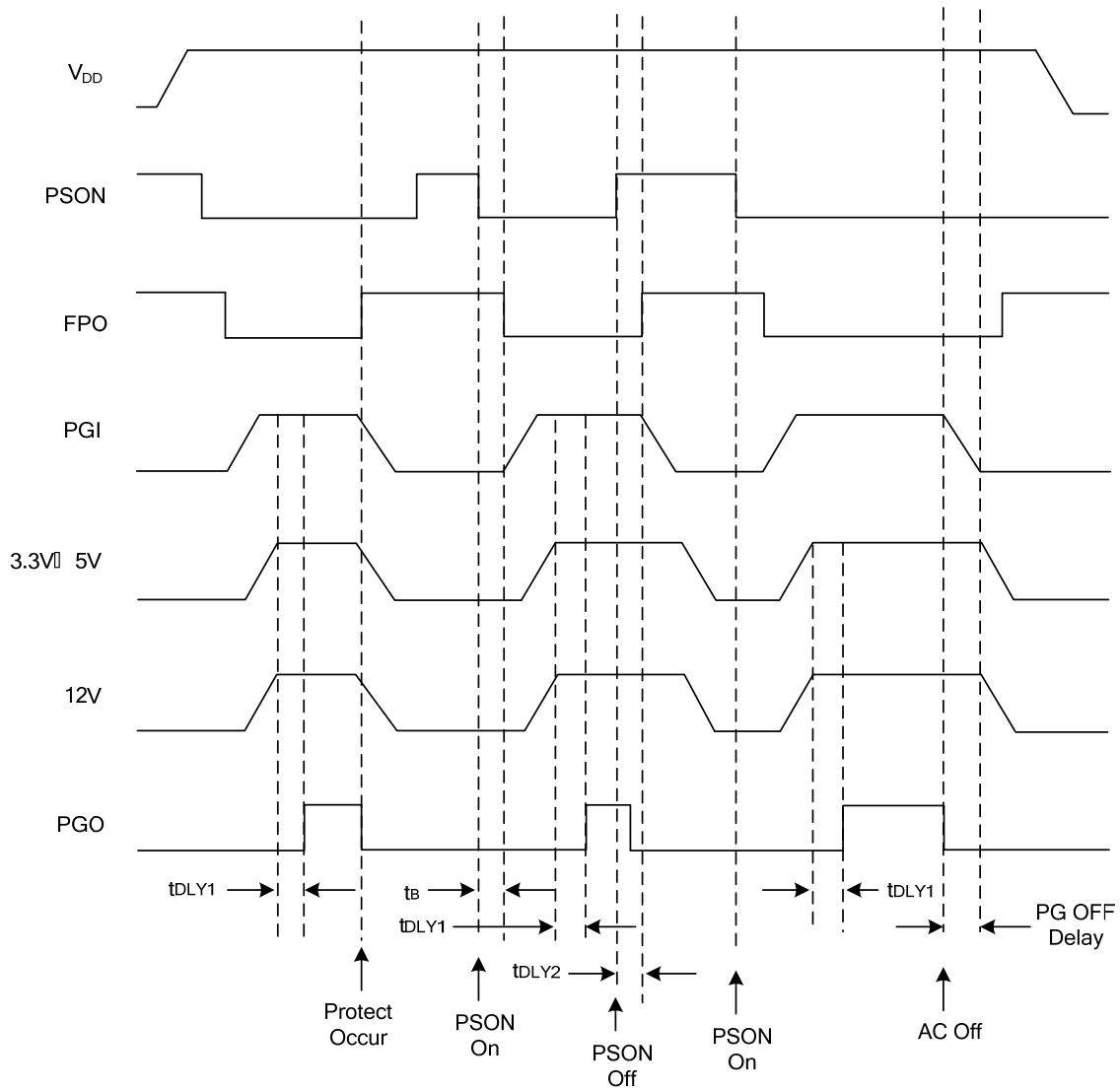

■ TYPICAL APPLICATION

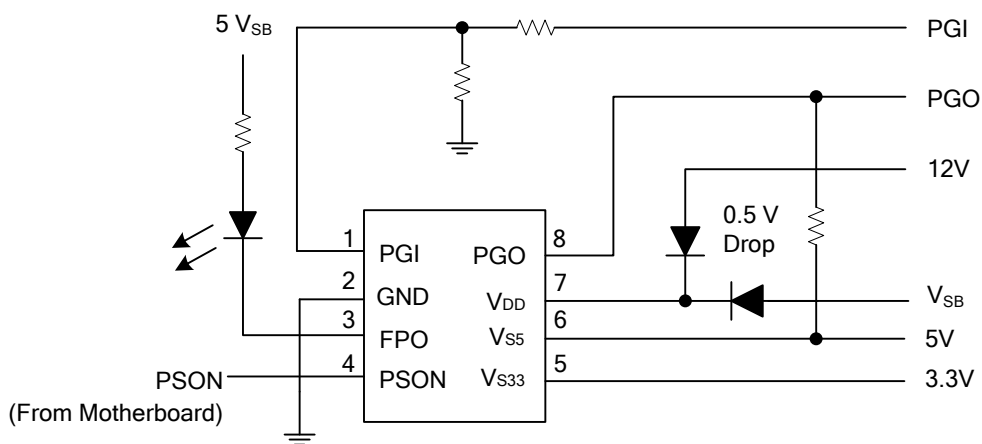

■ TYPICAL CHARACTERISTICS

SUPPLY CURRENT vs SUPPLY VOLTAGE

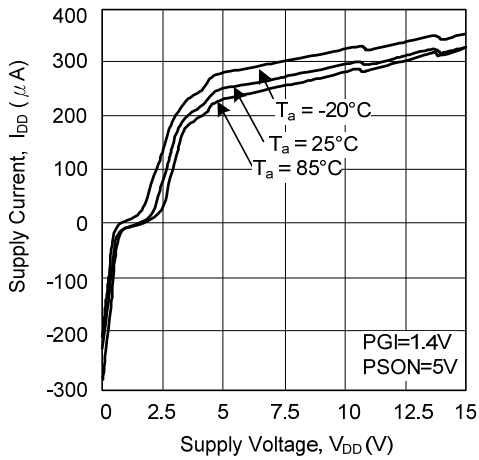

INPUT CURRENT (\overline{PSON}) vs INPUT VOLTAGE (\overline{PSON})

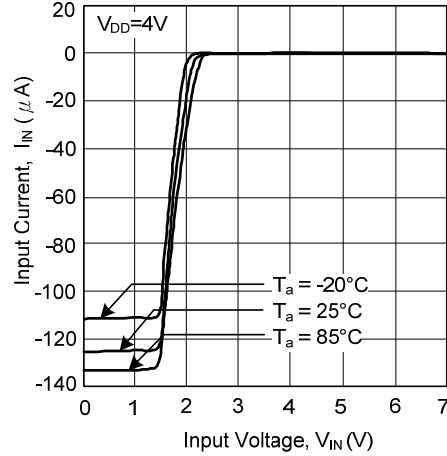

LOW-LEVEL OUTPUT VOLTAGE (\overline{FPO}) vs LOW-LEVEL OUTPUT CURRENT (\overline{FPO})

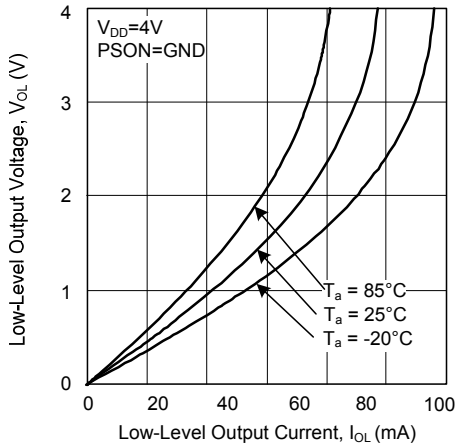

LOW-LEVEL OUTPUT VOLTAGE (\overline{FPO}) vs LOW-LEVEL OUTPUT CURRENT (\overline{FPO})

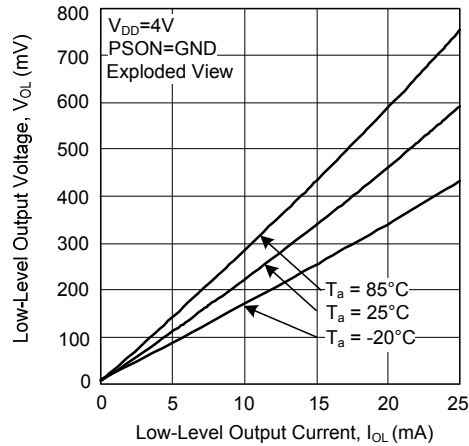

LOW-LEVEL OUTPUT VOLTAGE (PGO) vs LOW-LEVEL OUTPUT CURRENT (PGO)

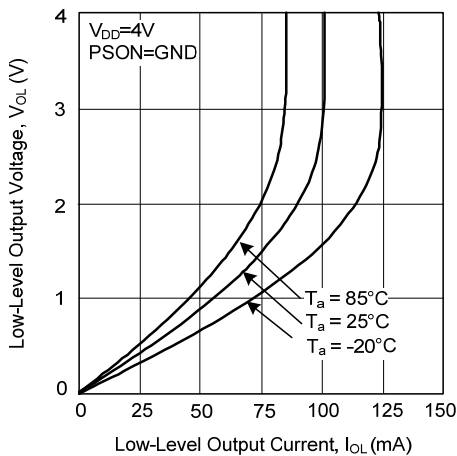

LOW-LEVEL OUTPUT VOLTAGE (PGO) vs LOW-LEVEL OUTPUT CURRENT (PGO)

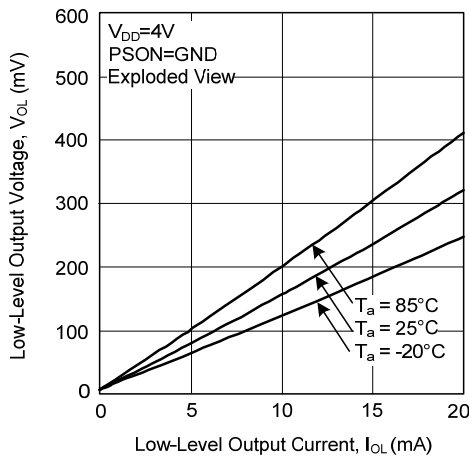

UTC assumes no responsibility for equipment failures that result from using products at values that exceed, even momentarily, rated values (such as maximum ratings, operating condition ranges, or other parameters) listed in products specifications of any and all UTC products described or contained herein. UTC products are not designed for use in life support appliances, devices or systems where malfunction of these products can be reasonably expected to result in personal injury. Reproduction in whole or in part is prohibited without the prior written consent of the copyright owner. The information presented in this document does not form part of any quotation or contract, is believed to be accurate and reliable and may be changed without notice.