



L5030

LINEAR INTEGRATED CIRCUIT

BOOST-UP VOLTAGE CONVERTER FOR LED DRIVER

DESCRIPTION

The **L5030** is a high efficiency boost converter operating in current loop, based on a PFM mode to drive LEDs. The current mode regulation allows the uniform brightness of LEDs. The wide application of **L5030** makes it suitable for many types of battery applications such as Li-ions, Alkaline, or Sealed Lead Acid battery. The combination of few external components and small package size keeps the converter board area to a minimum in space-restricted applications.

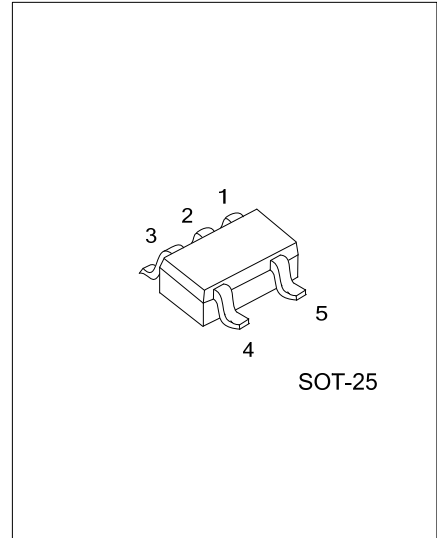

FEATURES

- * Inductor based converter brings up to 92% efficiency
- * +0.8V to +8.0V input voltage range
- * 0.92V guaranteed start up input voltage
- * Boost up control using PFM
- * Constant output current regulation

ORDERING INFORMATION

Ordering Number		Package	Packing
Lead Free	Halogen Free		
L5030L-AF5-R	L5030G-AF5-R	SOT-25	Tape Reel

<p>L5030L-AF5-R</p> <p>(1)Packing Type</p> <p>(2)Package Type</p> <p>(3)Lead Free</p>	<p>(1) R: Tape Reel</p> <p>(2) AF5: SOT-25</p> <p>(3) G: Halogen Free, L: Lead Free</p>
---	---

MARKING

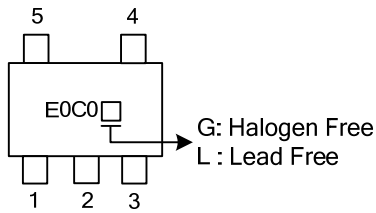

PIN DESCRIPTIONS

PIN NO.	SYMBOL	I/O	DESCRIPTION
1	V_{CC}		Supply voltage
2	GND		Ground
3	NC		No connection
4	I_{SENSE}	I	Current sense input
5	V_{DRIVE}	O	Output drive for external switching transistor. Connected to the base of external switching transistor.

BLOCK DIAGRAM

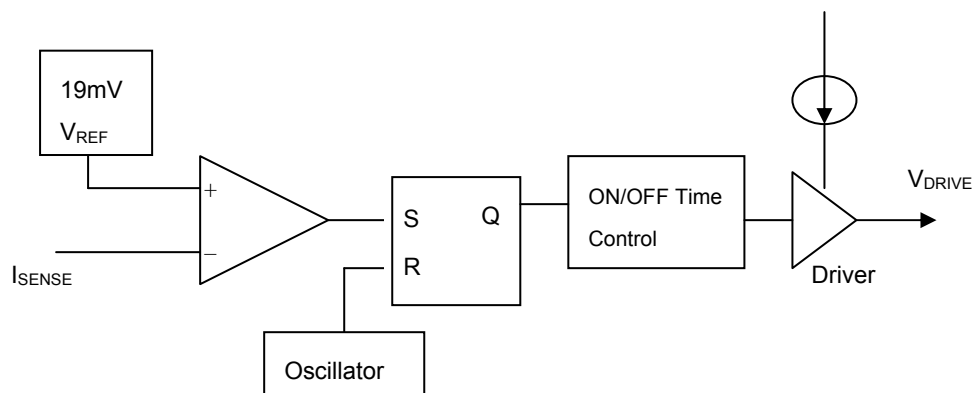

■ DEVICE DESCRIPTION

The UTC **L5030** is designed to supply a constant current to the external load, the circuit be powered a battery supply. An external transistor is required for LED application. The UTC **L5030** guarantees the start up voltage as low as 0.92V and remains operation down to 0.8V.

The basic structure of UTC **L5030** is a step-up DC/DC converter. It offers a Pulse Frequency Modulation (PFM) operation, which controls the constant OFF time (1.7 μ s typically) for external transistor at the 200KHz maximum frequency.

The external switching transistor is ON and kept on until the voltage across the current-sense resistor which is connected in series with the emitter of the switching transistor exceeds the I_{SENSE} input threshold (19mV). The transistor is shut OFF and the energy stored in inductor is discharged when I_{SENSE} input threshold exceeds 19mV. Once the discharge cycle is completed, the external transistor is ON again. This charging and discharging sequence will repeat and trigger the external transistor regardless the inductor current value.

■ **ABSOLUTE MAXIMUM RATINGS** ($T_A = 25^\circ\text{C}$, unless otherwise specified)

PARAMETER	SYMBOL	RATINGS	UNIT
Supply Voltage	V_{CC}	-0.3 ~ 10	V
Input Voltage		-0.3 ~ $V_{CC}+0.3$	V
Power Dissipation	P_D	450	mW
Operating Temperature	T_{OPR}	-40 ~ +85	$^\circ\text{C}$
Storage Temperature	T_{STG}	-55 ~ +125	$^\circ\text{C}$

Note: Absolute maximum ratings are those values beyond which the device could be permanently damaged.

Absolute maximum ratings are stress ratings only and functional device operation is not implied.

■ **ELECTRICAL CHARACTERISTICS** ($V_{CC}=1.5\text{V}$)

PARAMETER	SYMBOL	TEST CONDITIONS	MIN	TYP	MAX	UNITS
DC PARAMETERS ($T_A=25^\circ\text{C}$, unless otherwise specified.)						
Recommended Supply Voltage	V_{CC}		0.8		8	V
Minimum Startup Voltage	$V_{SU(MIN)}$	$I_{DRIVE}=-600\mu\text{A}$, $V_{DRIVE}=0.7\text{V}$		0.8	0.92	V
Drive Voltage	High	$V_{ISENSE} = 0\text{V}$, $I_{VDRIVE} = -0.5\text{mA}$	$V_{CC}-0.3$		V_{CC}	V
	Low	$V_{ISENSE} = 50\text{mV}$, $I_{VDRIVE} = 5\text{mA}$	0		0.25	V
I_{SENSE} Threshold Voltage	V_{ISENSE}		14	19	24	mV
Efficiency(Note 1)	η			88	92	%
Quiescent Current(Note 2)	I_Q			0.2		mA
V_{DRIVE} Output Current	I_{VDRIVE}	$V_{DRIVE} = 0.7\text{V}$, $V_{ISENSE} = 0\text{V}$	1.5		3.6	mA
Supply Current(Note 3)	I_{CC}	$V_{DRIVE} = 0.7\text{V}$, $V_{ISENSE} = 0\text{V}$	2		4	mA
I_{SENSE} Voltage Temp Co.(Note 2)	$T_{CVISENSE}$			0.4		$\%/^\circ\text{C}$
I_{SENSE} Input Current	I_{ISENSE}	$V_{ISENSE} = 0\text{V}$	0	-30	-65	μA
AC PARAMETERS (Note 2) ($T_A = 0 \sim 70^\circ\text{C}$, unless otherwise specified)						
Discharge Pulse Width	T_{DRV}		1.2	1.7	3.2	μs
PFM Operating Frequency (Note 4)	F_{OSC}				350	kHz

Note 1. The application dependent, please see reference designs.

2. These parameters are guaranteed by design.

3. See typical characteristics. The total supply current = $I_Q + I_{VDRIVE}$,

4. See applications section. Operating frequency is application circuit dependent.

■ TYPICAL APPLICATION CIRCUITS

The UTC **L5030** provides portable and multiple LEDs applications.

Solution for portable application

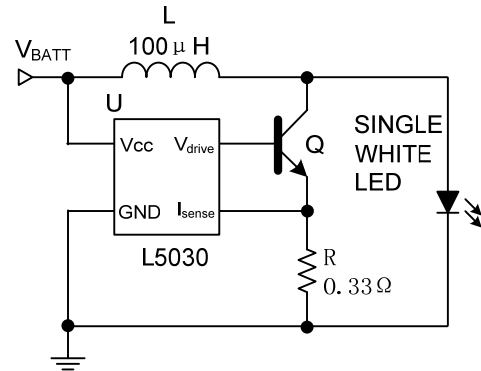
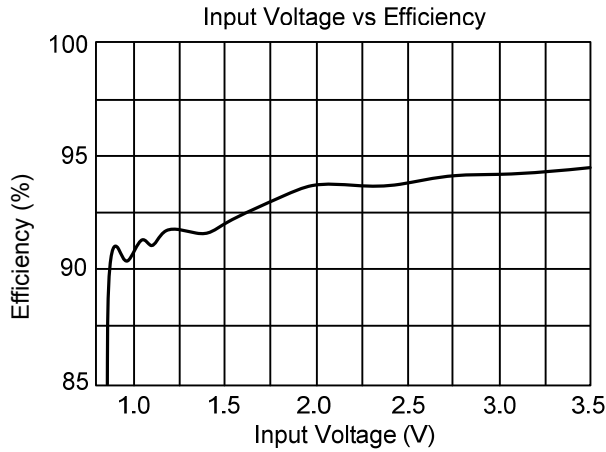

Solution for multiple LEDs application

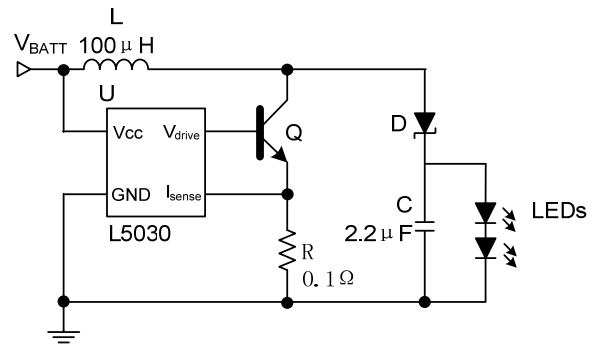
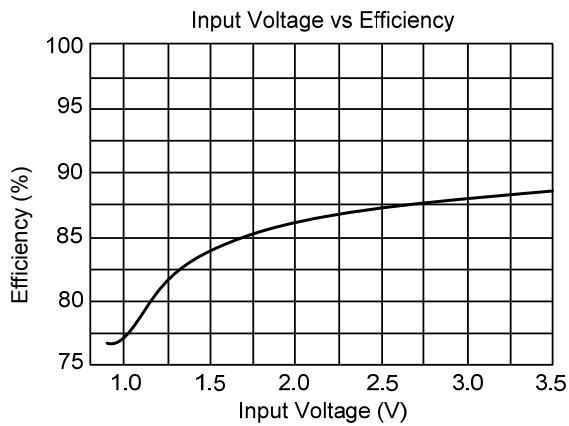

■ TYPICAL CHARACTERISTICS

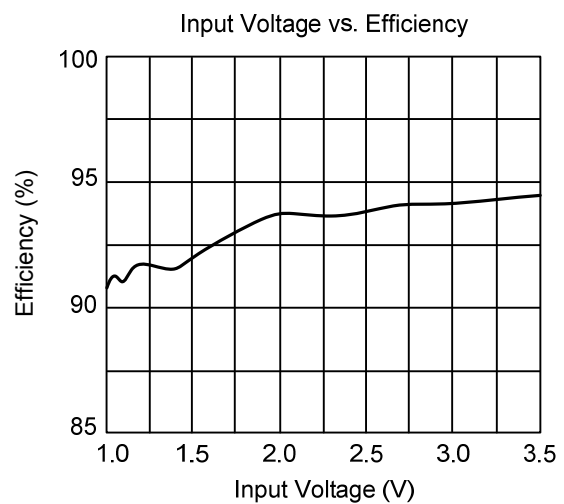
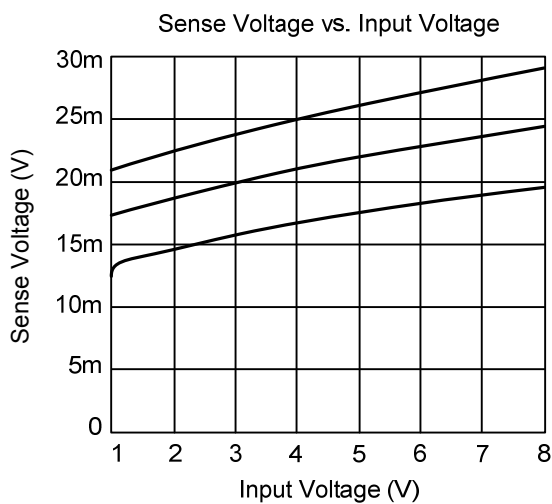
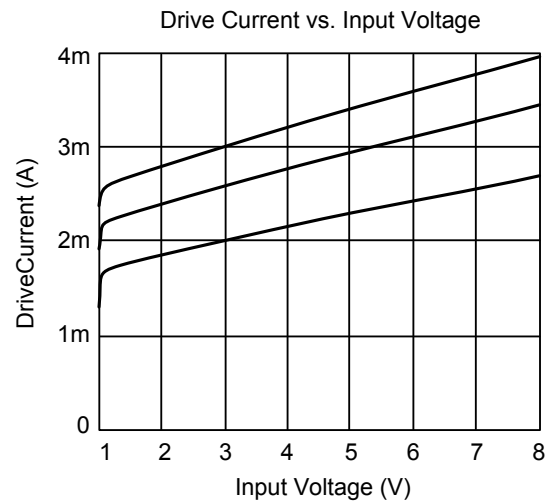
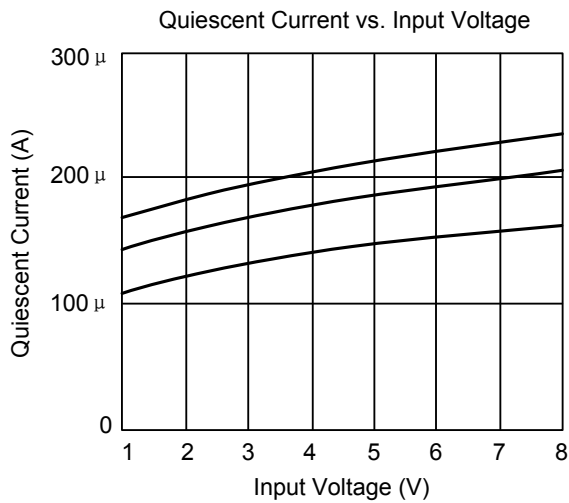

UTC assumes no responsibility for equipment failures that result from using products at values that exceed, even momentarily, rated values (such as maximum ratings, operating condition ranges, or other parameters) listed in products specifications of any and all UTC products described or contained herein. UTC products are not designed for use in life support appliances, devices or systems where malfunction of these products can be reasonably expected to result in personal injury. Reproduction in whole or in part is prohibited without the prior written consent of the copyright owner. The information presented in this document does not form part of any quotation or contract, is believed to be accurate and reliable and may be changed without notice.