



L2800

LINEAR INTEGRATED CIRCUIT

SWITCHING REGULATOR CONTROLLER(LOW VOLTAGE)

DESCRIPTION

The UTC L2800 which is incorporating a soft start function and short circuit detection function is a single-channel switching regulator control IC and is made for low voltage applications. Because the device has a low minimum operating voltage of 1.8V, so it is ideal for the power supply of battery-operated electronic equipment.

FEATURES

- *Wide supply voltage operating range: 1.8V~15V
- *Low current consumption: Typically 5.5mA in operation, 1µA or less in stand-by
- *High speed operation is possible: Maximum 1MHz
- *The error amplifier gain is set inside the IC, so peripheral components are minimized.
- *Incorporates a soft start circuit.
- *Incorporates a timer-latch type short circuit detection circuit (SCP).
- *Totem-pole type output with adjustable on/off current (for NPN transistors)
- *Incorporates a stand-by function.

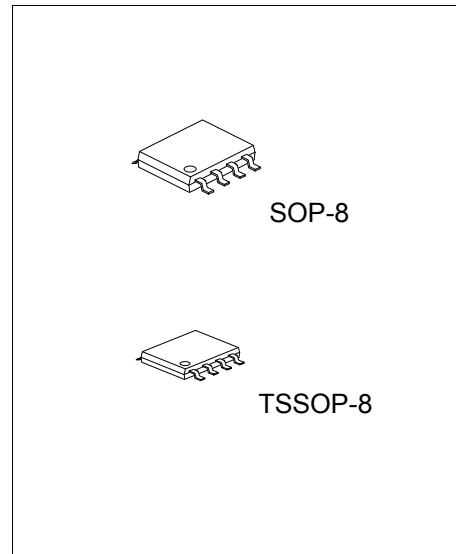

ORDERING INFORMATION

Ordering Number		Package	Packing
Lead Free	Halogen Free		
L2800L-S08-T	L2800G-S08-T	SOP-8	Tube
L2800L-S08-R	L2800G-S08-R	SOP-8	Tape Reel
L2800L-P08-T	L2800G-P08-T	TSSOP-8	Tube
L2800L-P08-R	L2800G-P08-R	TSSOP-8	Tape Reel

<p>L2800L-S08-T</p> <p>(1)Packing Type (2)Package Type (3)Lead Free</p>	<p>(1) T: Tube, R: Tape Reel (2) S08: SOP-8, P08: TSSOP-8 (3) L: Lead Free, G: Halogen Free</p>
---	---

PIN CONFIGURATION

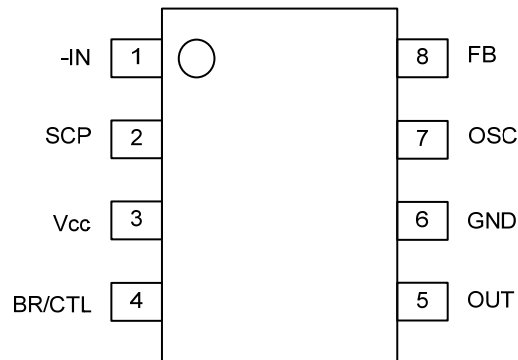

PIN DESCRIPTION

PIN NO.	SYMBOL	I/O	DESCRIPTION
1	-IN	I	Error amplifier inverting input pin
2	SCP	-	Soft start and SCP setting capacitor connection pin
3	VCC	-	Power supply pin
4	BR/CTL	I	Output current setting and control pin
5	OUT	O	Totem-pole type output pin
6	GND	-	Ground pin
7	OSC	-	Capacitor and resistor connection pin for setting the oscillation frequency
8	FB	O	Error amplifier output pin

BLOCK DIAGRAM

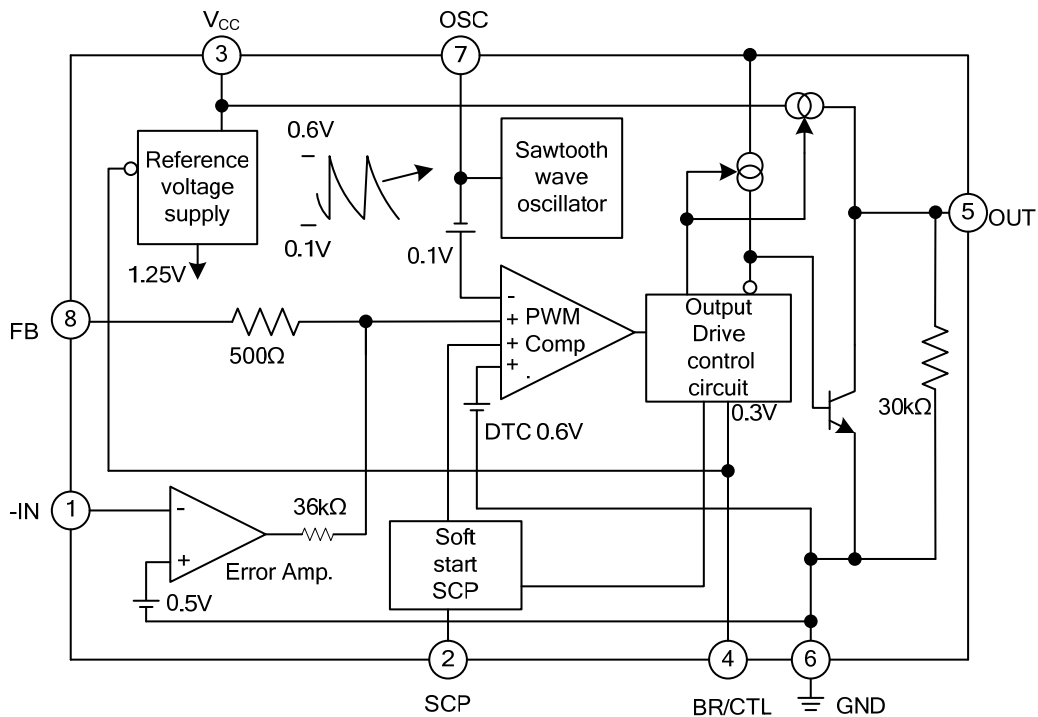

■ ABSOLUTE MAXIMUM RATINGS (T_A=25°C)

PARAMETER		SYMBOL	RATINGS	UNIT
Power Supply Voltage		V _{CC}	16	V
Output Source Current		I _O ⁺	-50	mA
Output Sink Current		I _O ⁻	50	mA
Power Dissipation (Note2)	SOP-8	P _D	570	mW
	TSSOP-8		580	
Storage Temperature		T _{STG}	-55 ~ +125	°C
Operating Temperature		T _{OPR}	-30 ~ +85	°C

Notes: 1. Absolute maximum ratings are those values beyond which the device could be permanently damaged.

Absolute maximum ratings are stress ratings only and functional device operation is not implied.

2. When mounted on a 10cm square double-sided epoxy board.

■ RECOMMENDED OPERATING CONDITIONS (T_A=25°C)

PARAMETER	SYMBOL	MIN	TYP	MAX	UNIT
Power Supply Voltage	V _{CC}	1.8		15	V
Error Amplifier Input Voltage	V _I	-0.2		1.0	V
BR/CTL Pin Input Voltage	V _{BR}	-0.2		V _{CC}	V
Output Source Current	I _O ⁺	-40			mA
Output Sink Current	I _O ⁻			40	mA
SCP Pin Capacitance	C _{PE}		0.1		μF
Phase Compensation Capacitance	C _P		0.1		μF
Output Current Setting Resistance	R _B	150	390	5000	Ω
Timing Resistance	R _T	1.0	3.0	10.0	kΩ
Timing Capacitance	C _T	100	270	10000	pF
Oscillation Frequency	f _{OSC}	10	500	1000	kHz
Operating Temperature	T _{OPR}	-30	+25	+85	°C

■ ELECTRICAL CHARACTERISTICS (T_A=25°C, V_{CC}=+2V)

PARAMETER	SYMBOL	TEST CONDITIONS	MIN	TYP	MAX	UNIT
CIRCUIT TO PREVENT MALFUNCTION AT LOW INPUT VOLTAGE (U.V.L.O)						
Reset Voltage	V _R				0.9	V
Threshold Voltage	V _{TH}		1.1	1.3	1.5	V
Soft Start						
Charging Current	I _{CS}	V _{SCP} =0V	-1.5	-1.0	-0.7	μA
Voltage at soft start completion	V _{TS}		0.7	0.8	0.9	V
Short Circuit Detection(S.C.P.)						
Charging Current	I _{CPC}	V _{SCP} =0V	-1.5	-1.0	-0.7	μA
Threshold Voltage	V _{TPC}		0.7	0.8	0.9	V
SAWTOOTH WAVE OSCILLATOR(OSC)						
Oscillation Frequency	f _{OSC}	R _T =3.0kΩ, C _T =270pF	400	500	600	kHz
Frequency Input Stability	f _{DV}	V _{CC} =2V ~ 15V		2	10	%
Frequency Variation With Temperature	f _{DT}	T _A =-30°C ~ +85°C		5		%
ERROR AMPLIFIER						
Input Threshold Voltage	V _T	V _{FB} =450mV	480	500	520	mV
V _T Input Stability	V _{TDV}	V _{CC} =2V ~ 15V		5	20	mV
V _T Variation With Temperature	V _{TDT}	T _A = -30°C ~ +85°C		1		%
Input Bias Current	I _B	V _{IN} =0V	-1.0	-0.2	1.0	μA
Voltage Gain	A _V		70	100	145	V/V
Frequency Bandwidth	BW	A _V =0dB		6		MHz
Maximum Output Voltage Range	V _{OM} ⁺		0.78	0.87		V
	V _{OM} ⁻			0.05	0.2	V
Output Source Current	I _{OM} ⁺	V _{FB} =0.45V		-40	-24	μA
Output Sink Current	I _{OM} ⁻		24	40		μA
IDLE PERIOD ADJUSTMENT SECTION						
Maximum Duty Cycle	t _{DUTY}	R _T =3.0kΩ, C _T =270pF, V _{FB} =0.8V	65	75	85	%
OUTPUT SECTION						
Output Voltage	V _{OH1}	R _B =390Ω, I _O =-15mA	1.0	1.2		V
	V _{OH2}	R _B =750Ω, V _{CC} =1.8V, I _O = -10mA	0.8	1.0		V
	V _{OL1}	R _B =390Ω, I _O =15mA		0.1	0.2	V
	V _{OL2}	R _B =750Ω, V _{CC} =1.8V, I _O =10mA		0.1	0.2	V
Output Source Current	I _O ⁺	R _B =390Ω, V _O =0.9V		-30	-20	mA
Output Sink Current	I _O ⁻	R _B =390Ω, V _O =0.3V	30	60		mA
Pull Down Resistance	R _O		20	30	40	kΩ
OUTPUT CURRENT SETTING SECTION/CONTROL SECTION						
Pin Voltage	V _{BR}	R _B =390Ω	0.2	0.3	0.4	V
Input Off Condition	I _{OFF}		-20		0	μA
Input On Condition	I _{ON}				-45	μA
Pin Current Range	I _{BR}		-1.8		-0.1	mA
ENTIRE DEVICE						
Stand-by Current	I _{CCS}	BR/CTL pin open or V _{CC}			1	μA
Average Supply Current	I _{CC}	R _B =390Ω		5.5	9.3	mA

■ DIAGRAM

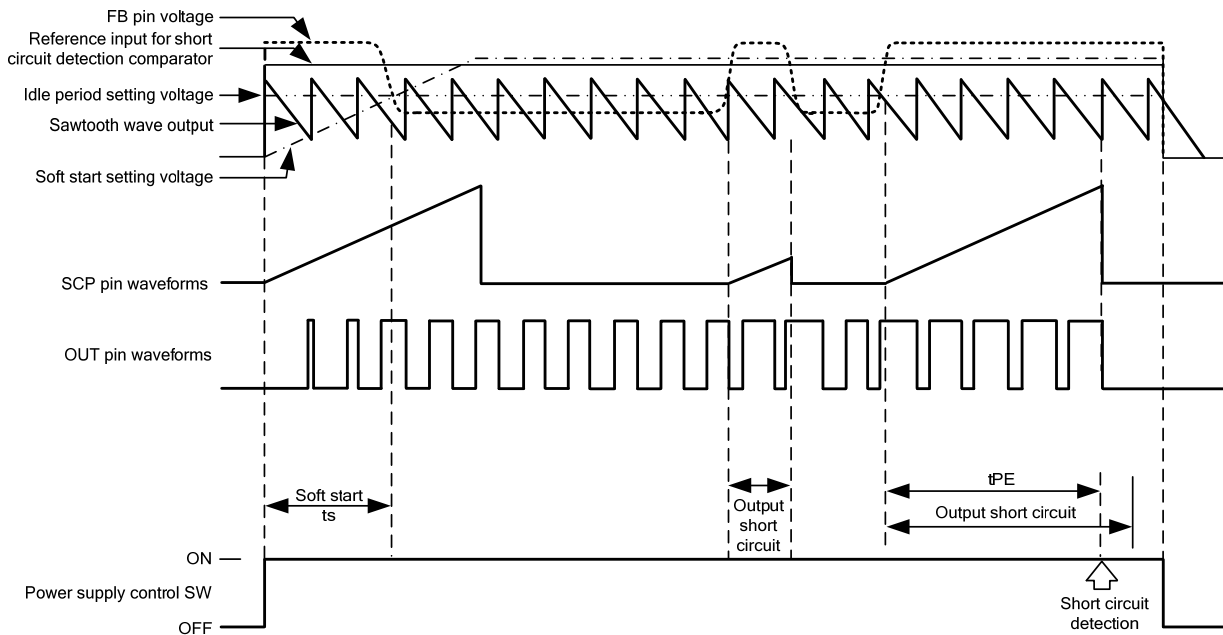

■ HOW TO SET THE TIME CONSTANT FOR SHORT CIRCUIT DETECTION AND SOFT START

1. SHORT CIRCUIT PROTECTION

The error amplifier output (FB pin) is fixed at V_{OM}^+ and capacitor C_{PE} starts charging if the switching regulator output suddenly drops due to load effect. The output pin is set low and the SCP pin stays low when the voltage at the SCP pin reaches approximately 0.8V.

As the protection circuit operates, by resetting the power supply the circuit will be restored.

•Short circuit detection time

$$t_{PE}[S] \approx 0.8 \times C_{PE}[\mu F]$$

2. SOFT START

Once power on, the capacitor C_{PE} which is connected to the SCP pin starts charging. The soft start setting voltage is compared by the PWM comparator as the voltage's proportion at the SCP pin with the sawtooth waveform. The comparison controls the OUT pin's ON duty, which is causing the soft start operation. During the time for completion of soft start operation, the SCP pin's voltage stays low, but the soft start setting voltage stays high, and the circuit then enters the output short circuit detection wait state.

Soft start time (until the output ON duty reaches approximately 50%)

$$t_s[S] \approx 0.35 \times C_{PE}[\mu F]$$

■ APPLICATION EXAMPLE

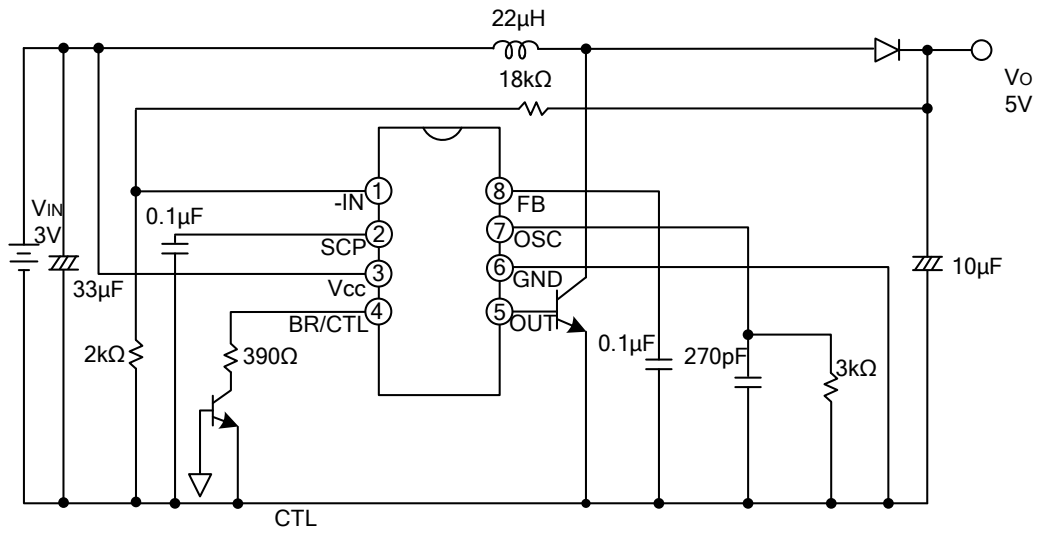

■ TYPICAL CHARACTERISTICS

OSC Pin Voltage vs. Output Pin Voltage

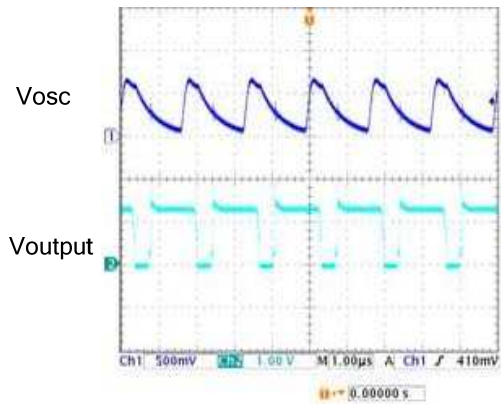

UTC assumes no responsibility for equipment failures that result from using products at values that exceed, even momentarily, rated values (such as maximum ratings, operating condition ranges, or other parameters) listed in products specifications of any and all UTC products described or contained herein. UTC products are not designed for use in life support appliances, devices or systems where malfunction of these products can be reasonably expected to result in personal injury. Reproduction in whole or in part is prohibited without the prior written consent of the copyright owner. The information presented in this document does not form part of any quotation or contract, is believed to be accurate and reliable and may be changed without notice.