



LR9200

CMOS IC

LOW NOISE 200mA LDO REGULATOR

DESCRIPTION

The UTC LR9200 is a typical LDO with the features of high output voltage accuracy, low supply current, low ON-resistance, and high ripple rejection.

During operation of the UTC LR9200, the dropout voltage is very low and the response of line transient and load transient are very well.

Internally, there're many functions of UTC LR9200 which can be seen in the block figure. There are a voltage reference unit, an error amplifier, resistor-net for voltage setting, a current limit circuit, and a chip enable circuit in each UTC LR9200.

The UTC LR9200 can be used as an ideal of the power supply for hand-held communication equipment, such as: power source for portable communication equipment, power source for electrical appliances, for example, cameras, VCRs and camcorders and power source for battery-powered equipment.

FEATURES

- * Ultra Supply Current: 20µA (Typ.)
- * Standby Mode: 0.1µA (Typ.)
- * Very Low Dropout Voltage: 0.13V (Typ.)
@I_{OUT}=150mA, V_{OUT}=2.85V
- * Ripple Rejection: 75dB (Typ.)
@f=1kHz, V_{OUT}=2.85V
- * Temperature-Drift Coefficient of Output Voltage: ± 30ppm/°C (Typ.)
- * Well Line Regulation: 0.02% / V (Typ.)
- * Output Voltage Accuracy: ± 0.8% (Typ.)
- * Internal Fold Back Protection Circuit: 40mA (Typ.) @ short mode
- * C_{IN}=C_{OUT}=1µF or more (Ceramic capacitors) are recommended to be used with this IC

ORDERING INFORMATION

Ordering Number		Package	Pin Assignment					Packing
Lead Free	Halogen Free		1	2	3	4	5	
LR9200L-xx-AF5-R	LR9200G-xx-AF5-R	SOT-25	V _{IN}	G	CE	NC	O	Tape Reel
LR9200L-xx-AB3-C-R	LR9200G-xx-AB3-C-R	SOT-89	G	I	O	-	-	Tape Reel

Note: xx: Output Voltage, refer to Marking Information.

<p>LR9200L-xx-AF5-x-R</p>	<ul style="list-style-type: none"> (1) R: Tape Reel (2) refer to Pin Assignment (3) AF5: SOT-25, AB3: SOT-89 (4) xx: Refer to Marking Information (5) L: Lead Free, G: Halogen Free
---------------------------	----------------------------------------------------------------------------------------------------------------------------------------------------------------------------------------------------------------------------------------

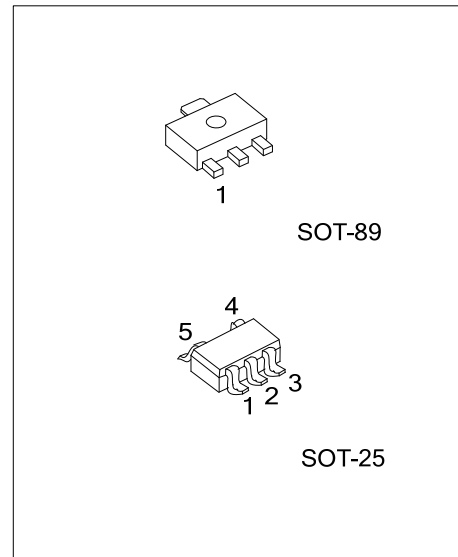

MARKING

PACKAGE	VOLTAGE CODE	MARKING
SOT-89	12: 1.2V 15: 1.5V 16: 1.6V 18: 1.8V 20: 2.0V	
SOT-25	25: 2.5V 2J: 2.85V 30: 3.0V 33: 3.3V 50: 5.0V	

PIN CONFIGURATION

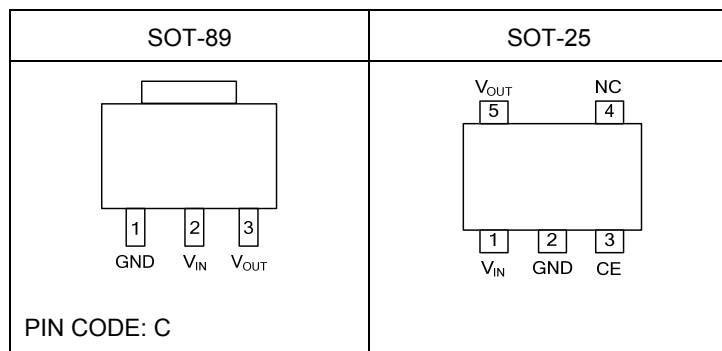

PIN DESCRIPTIONS

PIN NAME	DESCRIPTION
V_{IN}	Input Pin
GND	Ground Pin
CE	Chip Enable Pin. Active when this Pin is high.
NC	No Connection
V_{OUT}	Output Pin

BLOCK DIAGRAM

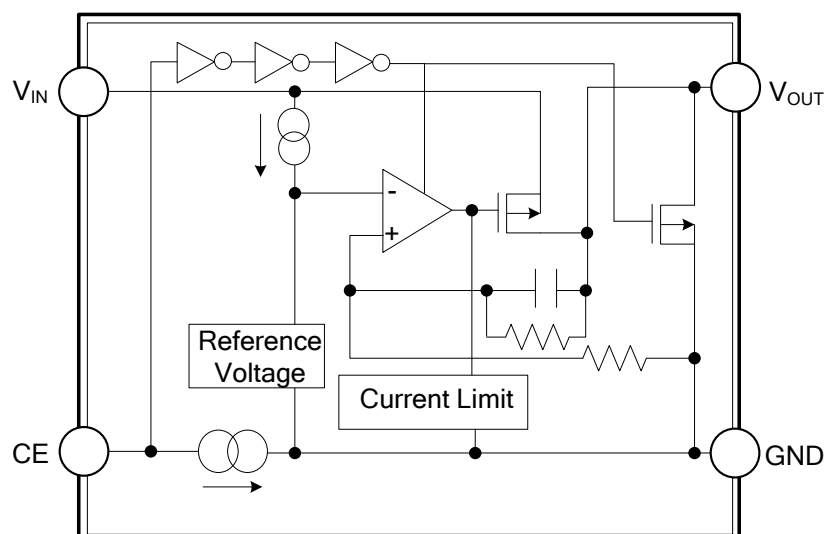

■ ABSOLUTE MAXIMUM RATING

PARAMETER	SYMBOL	RATINGS	UNIT
Input Voltage	V_{IN}	9	V
Input Voltage(CE Pin)	V_{CE}	8.5	V
Output Voltage	V_{OUT}	$-0.3 \sim V_{IN}+0.3$	V
Output Current	I_{OUT}	300	mA
Power Dissipation	SOT-25	P_D	mW
	SOT-89		
Junction Temperature	T_J	+125	°C
Operating Temperature	T_{OPR}	-40~+85	°C
Storage Temperature	T_{STG}	-55~+125	°C

Note: Absolute maximum ratings are those values beyond which the device could be permanently damaged.
 Absolute maximum ratings are stress ratings only and functional device operation is not implied.

■ ELECTRICAL CHARACTERISTICS

($T_A=25^\circ\text{C}$, $V_{IN}=\text{Set } V_{OUT}+1\text{V}$, $I_{OUT}=1\text{mA}$, $C_I=C_O=1\mu\text{F}$, unless otherwise specified)

PARAMETER	SYMBOL	TEST CONDITIONS	MIN	TYP	MAX	UNIT
Output Voltage	V_{OUT}	$V_{IN} = \text{Set } V_{OUT}+1\text{V}$	$V_{OUT} > 2.0\text{V}$	$\times 0.992$	$\times 1.008$	V
			$V_{OUT} \leq 2.0\text{V}$	-16	+16	mV
Input Voltage	V_{IN}				7.5	V
Load Regulation	ΔV_{OUT}	$1\text{mA} \leq I_{OUT} \leq 150\text{mA}$		20	40	mV
Output Current	I_{OUT}		200			mA
Supply Current	I_{SS}	$I_{OUT}=0\text{A}$		20	40	μA
Supply Current (Standby)	I_{ST-BY}	$V_{CE}=0\text{V}$		0.1	2	μA
Short Current Limit	I_{LIMIT}	$V_{OUT}=0\text{V}$		40		mA
CE Pull-down Current	I_{PD}			0.3		μA
CE Input Voltage	High	V_{CEH}	1.5			V
	Low	V_{CEL}			0.3	V
Output Noise	eN	$B_W=10\text{Hz to } 100\text{kHz}$, $I_{OUT}=30\text{mA}$		30		μVrms
Ripple Rejection	RR	$f=1\text{kHz}$, Ripple 0.2V_{P-P} $V_{IN}=\text{Set } V_{OUT}+1\text{V}$, $I_{OUT}=30\text{mA}$ (In case that $V_{OUT}=2.0\text{V}$, $V_{IN}=3\text{V}$)		75		dB
Dropout Voltage	V_D	$I_{OUT}=150\text{mA}$	$1.2\text{V} \leq V_{OUT} < 1.5\text{V}$	0.40	0.50	V
			$1.5\text{V} \leq V_{OUT} < 1.7\text{V}$	0.24	0.38	
			$1.7\text{V} \leq V_{OUT} < 2.0\text{V}$	0.21	0.34	
			$2.0\text{V} \leq V_{OUT} < 2.5\text{V}$	0.17	0.30	
			$2.5\text{V} \leq V_{OUT} < 2.8\text{V}$	0.14	0.25	
			$2.8\text{V} \leq V_{OUT} \leq 5.0\text{V}$	0.13	0.23	
Line Regulation	$\frac{\Delta V_{OUT}}{\Delta V_{IN}}$	$1.2\text{V} \leq V_{OUT} \leq 4.0\text{V}$, $V_{SET}+0.5\text{V} \leq V_{IN} \leq 5\text{V}$		0.02	0.10	%V
		$4.0\text{V} < V_{OUT} \leq 5.0\text{V}$, $V_{SET}+0.5\text{V} \leq V_{IN} \leq 6.5\text{V}$				
Output Voltage Temperature Coefficient	$\frac{\Delta V_{OUT}}{\Delta T}$	$-40^\circ\text{C} \leq T_{OPR} \leq 85^\circ\text{C}$		± 30		ppm/°C
Low Output Nch Tr. ON Resistance	R_{LOW}	$V_{IN}=4.0, V_{CE}=0\text{V}$		70		Ω

■ TEST CIRCUIT

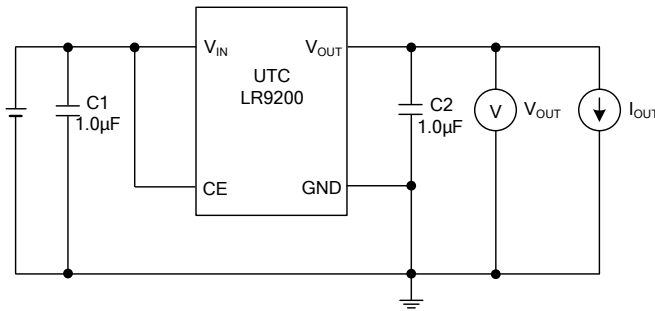

Basic Test Circuit

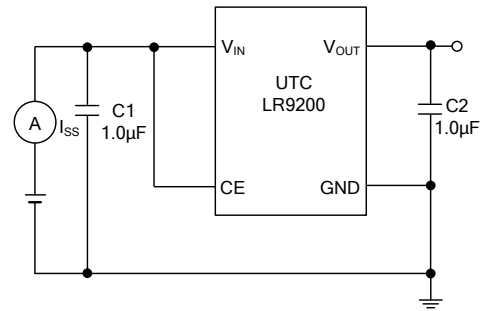

Test Circuit for Supply Current

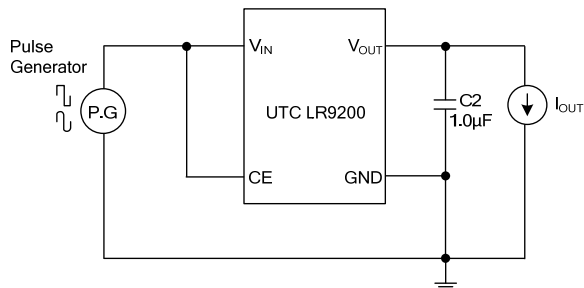

Test Circuit for Ripple Rejection

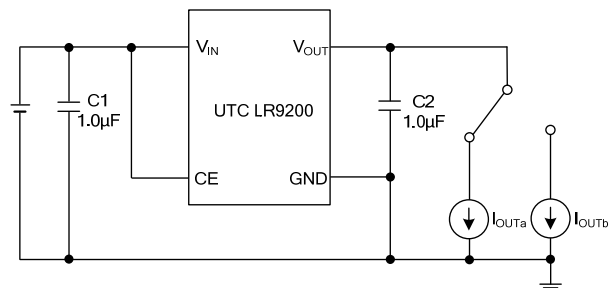

Test Circuit for Load Transient Response

■ TYPICAL APPLICATION CIRCUIT

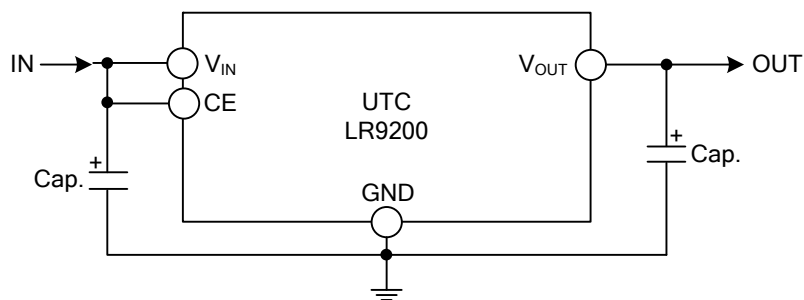

■ TYPICAL CHARACTERISTICS

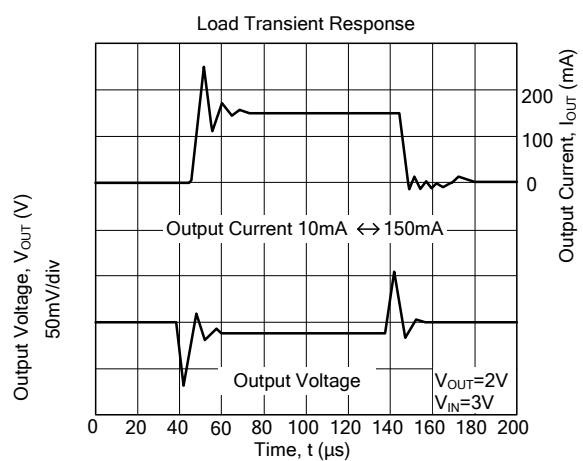
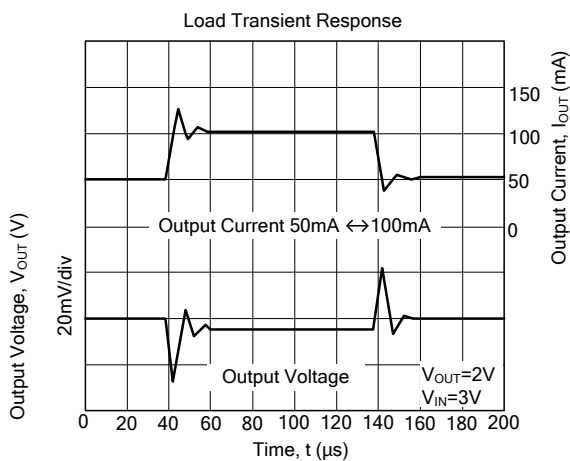
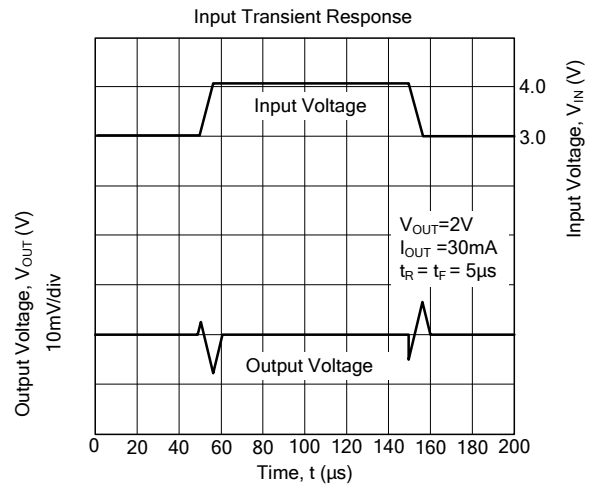
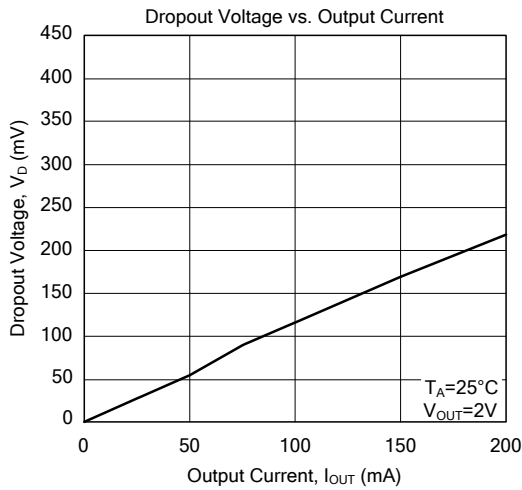
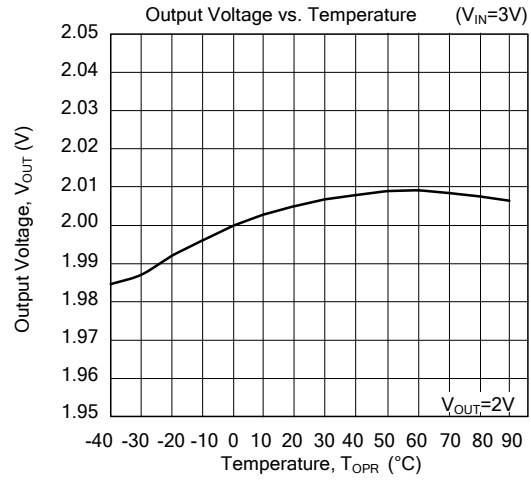
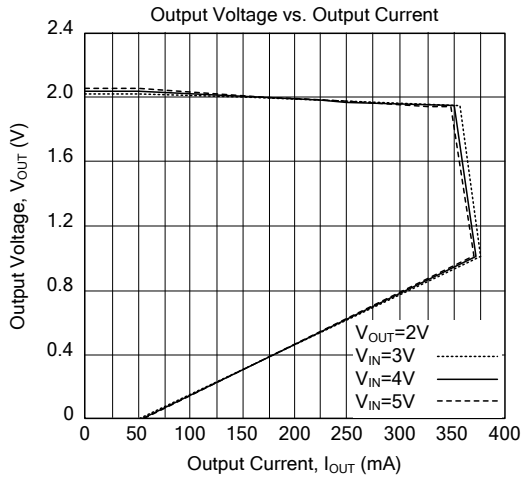

■ TYPICAL CHARACTERISTICS(Cont.)

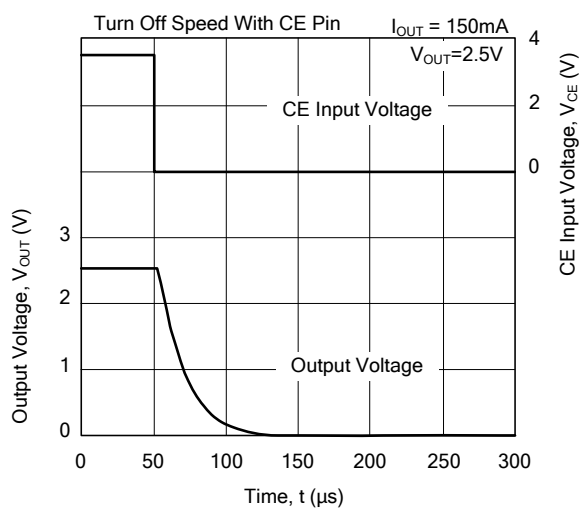
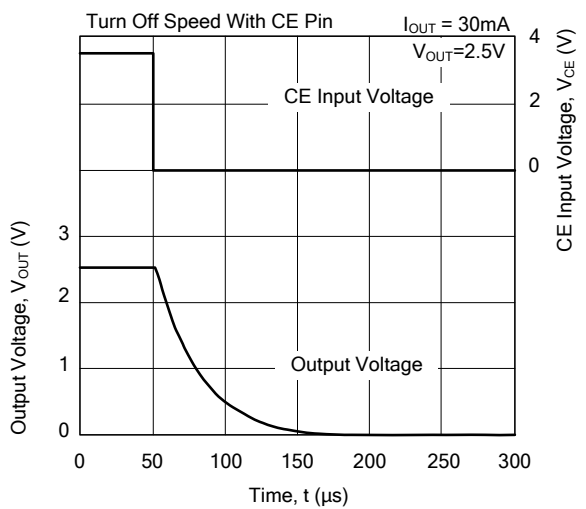
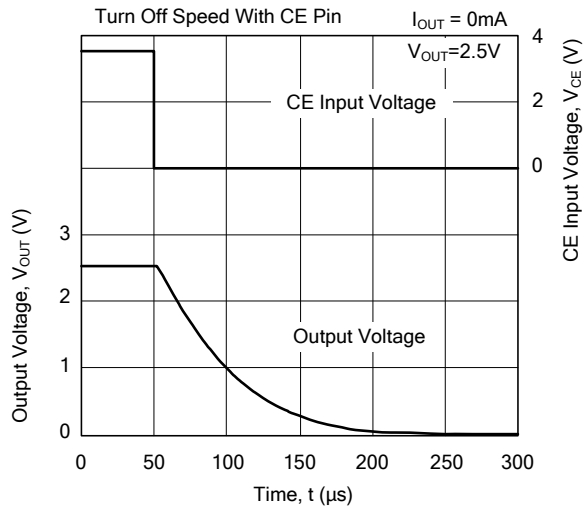
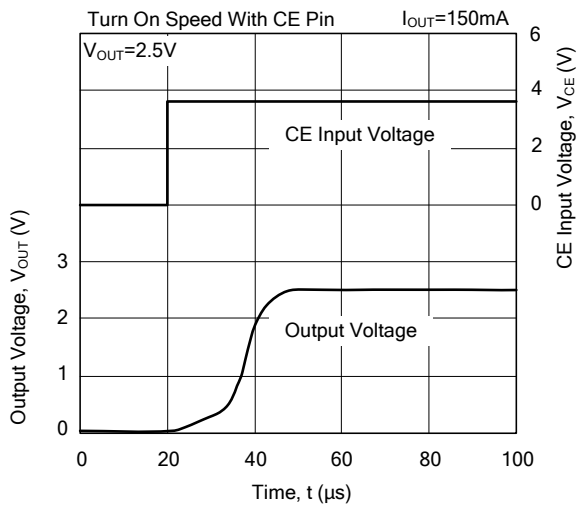
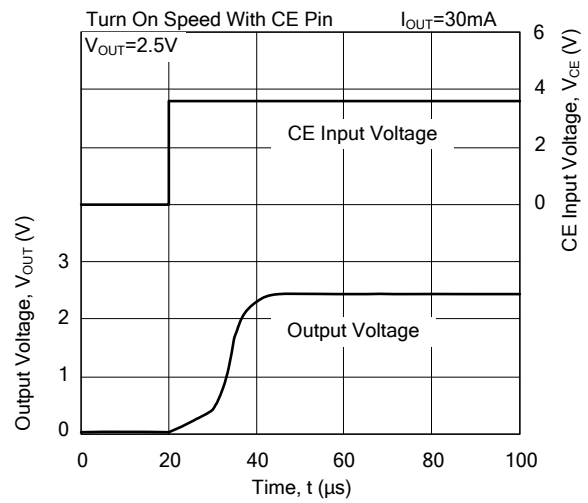
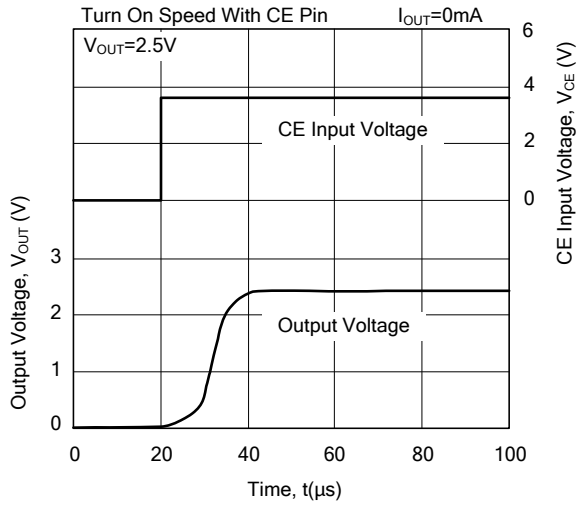

UTC assumes no responsibility for equipment failures that result from using products at values that exceed, even momentarily, rated values (such as maximum ratings, operating condition ranges, or other parameters) listed in products specifications of any and all UTC products described or contained herein. UTC products are not designed for use in life support appliances, devices or systems where malfunction of these products can be reasonably expected to result in personal injury. Reproduction in whole or in part is prohibited without the prior written consent of the copyright owner. The information presented in this document does not form part of any quotation or contract, is believed to be accurate and reliable and may be changed without notice.