



LOW VOLTAGE OPERATING 75Ω DRIVER

DESCRIPTION

The UTC **UM1671** is a low voltage operating 75Ω driver, operating supply voltage from 2.8V to 5.5V. Including a high-performance 4-order LPF, a available output gain built-in amp and a sag auxiliary circuit, etc.

The UTC **UM1671** is suitable for video signal output in devices ranging from portable equipment such as digital still cameras to stationary equipment such as DVD players.

FEATURES

- * Supports 3V and 5V systems
- * High-precision voltage gain
- * Including a high-performance 4-order LPF, a available output gain built-in amp and a sag auxiliary circuit

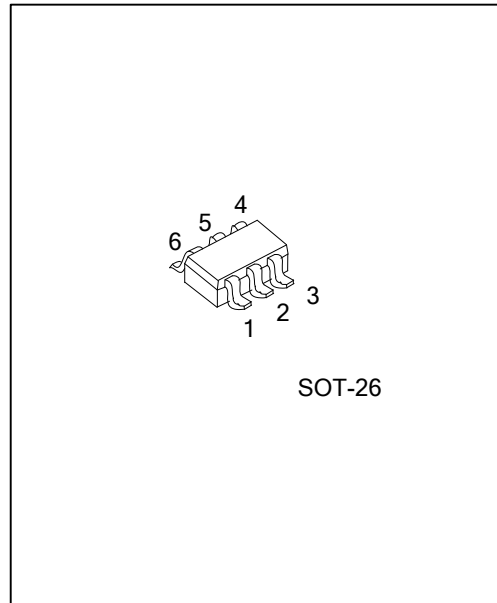

ORDERING INFORMATION

Ordering Number		Package	Packing
Lead Free	Halogen Free		
UM1671L-AG6-R	UM1671G-AG6-R	SOT-26	Tape Reel

Note: xx: Output Voltage, refer to Marking Information.

<p>UM1671G-AG6-R</p> <p>(1) Packing Type (2) Package Type (3) Halogen Free</p>	<p>(1) R: Tape Reel (2) AG6: SOT-26 (3) G: Halogen Free, L: Lead Free</p>
--	---

MARKING INFORMATION

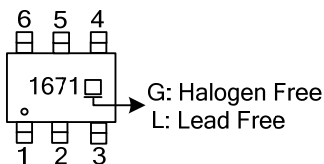

■ PIN CONFIGURATION

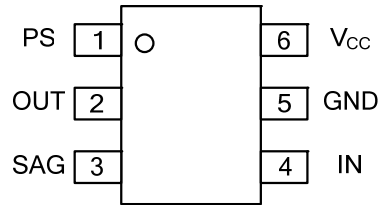

■ PIN DESCRIPTION

PIN NO.	PIN NAME	DESCRIPTION	INTERNAL EQUIVALENT CIRCUIT DIAGRAM
1	PS	Power Save	
2	OUT	Signal Output	
3	SAG	SAG Correction	
4	IN	Signal Input	
5	GND	GND	
6	V _{CC}	V _{CC}	

■ BLOCK DIAGRAM

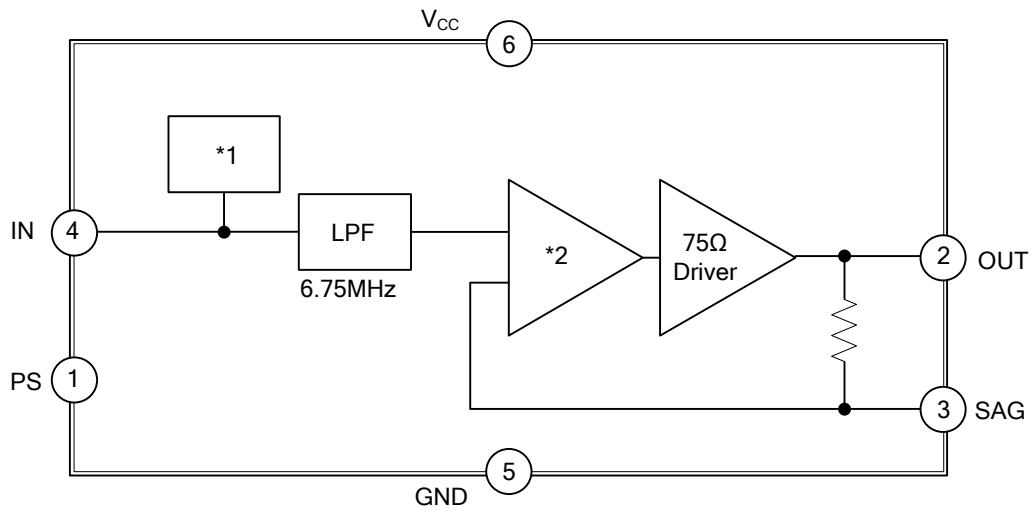

*1 INPUT CLAMP	*2 BUILT-IN AMPLIFIER
clamp	6dB(*2)

■ ABSOLUTE MAXIMUM RATING (T_A=25°C)

PARAMETER	SYMBOL	RATINGS	UNIT
Supply Voltage	V _{CC}	7 (MAX.)	V
Power Dissipation	P _D	200	mW
Storage Temperature	T _{STG}	-65~+150	°C
Operating Temperature	T _{OPR}	-40~+85	°C

Note: Absolute maximum ratings are those values beyond which the device could be permanently damaged.
 Absolute maximum ratings are stress ratings only and functional device operation is not implied.

■ RECOMMENDED OPERATING CONDITIONS

PARAMETER	SYMBOL	RATINGS	UNIT
Operating Voltage	V _{CCOP}	2.8~5.5	V
Operating Temperature	T _{OPR}	-40~+85	°C

■ ELECTRICAL CHARACTERISTICS (Except where noted otherwise, T_A=25°C, V_{CC}=3V)

PARAMETER	SYMBOL	TEST CONDITIONS	MIN	TYP	MAX	UNIT
Supply Current	I _{CC1}	No Signal		7	10	mA
Supply Current (At Power Save Mode)	I _{CC2}	No Signal, PS: ON			1	μA
Power Save Terminal Input Current	H	I _{PSH} 1PIN V _H =2.8V			360	μA
	L	I _{PSL} 1PIN V _L =0.2V			18	μA
Power Save Terminal Input Voltage	H	V _{PSH}	2.0		V _{CC}	V
	L	V _{PSL}			0.5	V
Input Terminal Voltage	V _{IN}	4PIN		1.2		V
Output Terminal Voltage	V _{OUT}	2PIN	0.15	0.3	0.45	V
Voltage Gain	G _V	SIN Wave: 1V, f=100kHz	5.7	6.0	6.3	dB
Frequency Characteristic 1	f _{C1}	SIN Wave: 1V, 6.75MHz/100kHz	-1.0	0	1.0	dB
Frequency Characteristic 2	f _{C2}	SIN Wave: 1V, 27MHz/100kHz		-40	-27	dB
Differential Gain	DG	Staircase Signal 1V		0.7	1.5	%
Differential Phase	DP	Staircase Signal 1V		0.7	1.5	°
Output Dynamic Range	DR	SIN Wave: 100kHz, THD=1.0%	2.2	2.4		V
S/N	SN	BW: 100k~6MHz		74		dB
Group Delay	t ₁	at 100kHz		50	80	ns
Group Delay	Δt ₁	to 3.58MHz		4	10	ns
		to 4.43MHz		6	10	ns
		to 6MHz		12	20	ns

■ SWITCH CONTROL TABLE

PS-PIN	POWER SAVE
H	OFF
L	ON
OPEN	ON

■ TEST CIRCUIT

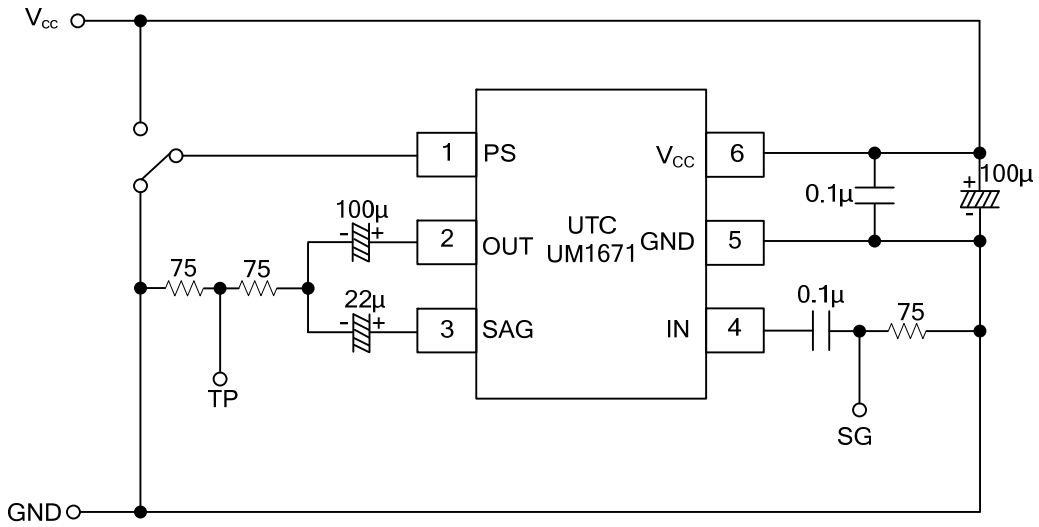

■ TYPICAL APPLICATION CIRCUIT

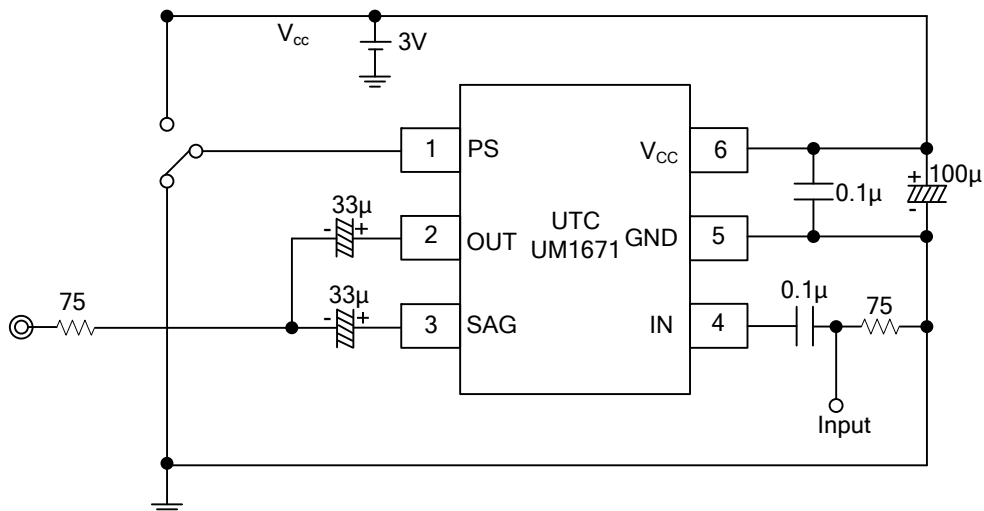
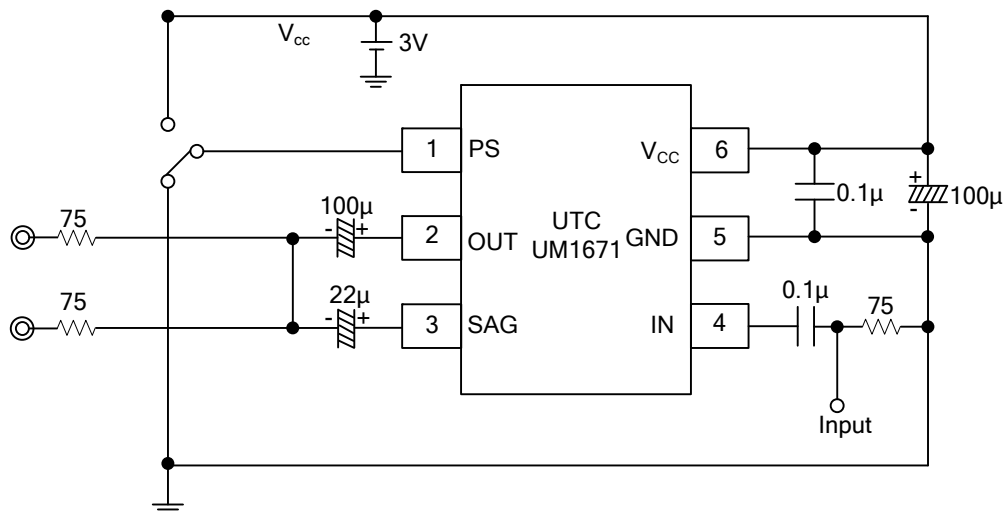

UTC assumes no responsibility for equipment failures that result from using products at values that exceed, even momentarily, rated values (such as maximum ratings, operating condition ranges, or other parameters) listed in products specifications of any and all UTC products described or contained herein. UTC products are not designed for use in life support appliances, devices or systems where malfunction of these products can be reasonably expected to result in personal injury. Reproduction in whole or in part is prohibited without the prior written consent of the copyright owner. The information presented in this document does not form part of any quotation or contract, is believed to be accurate and reliable and may be changed without notice.