

**LR3965****CMOS IC****1.5A LOW DROPOUT LINEAR REGULATOR****DESCRIPTION**

The UTC **LR3965** belonged to low-noise, low-dropout, linear regulators operate from 2.25V to 6V input and are guaranteed to deliver 1.5A. Wide range of preset output voltage options are available. Built-in low on-resistance transistor provides low dropout voltage and large output current. The UTC **LR3965** is designed and optimized for battery-powered systems to work with low noise.

The UTC **LR3965** consumes less than 0.01 $\mu$ A in shutdown mode. Other features include ultra low dropout voltage, current limiting protection, thermal shutdown protection and high ripple rejection ratio.

**FEATURES**

- \* 1.5A Guaranteed Output Current
- \* 0.01 $\mu$ A Shutdown Current
- \* 40mV Dropout at 150mA Load
- \* Low Temperature Coefficient
- \* Current Limiting Protection
- \* Thermal Shutdown Protection
- \* Excellent Line/Load Transient
- \* Sense Option Improves Load Regulation

**ORDERING INFORMATION**

Ordering Number		Package	Pin Assignment								Packing
Lead Free	Halogen Free		1	2	3	4	5	6	7	8	
LR3965L-xx-AB3-C-R	LR3965G-xx-AB3-C-R	SOT-89	G	I	O	-	-	-	-	-	Tape Reel
LR3965L-xx-AA3-A-R	LR3965G-xx-AA3-A-R	SOT-223	G	O	I	-	-	-	-	-	Tape Reel
LR3965L-xx-AA3-D-R	LR3965G-xx-AA3-D-R	SOT-223	I	G	O	-	-	-	-	-	Tape Reel
LR3965L-xx-TN3-A-R	LR3965G-xx-TN3-A-R	TO-252	G	O	I	-	-	-	-	-	Tape Reel
LR3965L-xx-TN3-A-T	LR3965G-xx-TN3-A-T	TO-252	G	O	I	-	-	-	-	-	Tube
LR3965L-xx-TN3-D-R	LR3965G-xx-TN3-D-R	TO-252	I	G	O	-	-	-	-	-	Tape Reel
LR3965L-xx-TN3-D-T	LR3965G-xx-TN3-D-T	TO-252	I	G	O	-	-	-	-	-	Tube
LR3965L-xx-TQ2-A-R	LR3965G-xx-TQ2-A-R	TO-263	G	O	I	-	-	-	-	-	Tape Reel
LR3965L-xx-TQ2-A-T	LR3965G-xx-TQ2-A-T	TO-263	G	O	I	-	-	-	-	-	Tube
LR3965L-xx-TQ2-D-R	LR3965G-xx-TQ2-D-R	TO-263	I	G	O	-	-	-	-	-	Tape Reel
LR3965L-xx-TQ2-D-T	LR3965G-xx-TQ2-D-T	TO-263	I	G	O	-	-	-	-	-	Tube
LR3965L-xx-TN4-R	LR3965G-xx-TN4-R	TO-252-4	S	I	G	O	A	-	-	-	Tape Reel
LR3965L-xx-TN4-T	LR3965G-xx-TN4-T	TO-252-4	S	I	G	O	A	-	-	-	Tube
LR3965L-xx-TN5-R	LR3965G-xx-TN5-R	TO-252-5	S	I	G	O	A	-	-	-	Tape Reel
LR3965L-xx-TN5-T	LR3965G-xx-TN5-T	TO-252-5	S	I	G	O	A	-	-	-	Tube
LR3965L-xx-TQ5-R	LR3965G-xx-TQ5-R	TO-263-5	S	I	G	O	A	-	-	-	Tape Reel
LR3965L-xx-TQ5-T	LR3965G-xx-TQ5-T	TO-263-5	S	I	G	O	A	-	-	-	Tube
LR3965L-xx-S08-R	LR3965G-xx-S08-R	SOP-8	S	I	O	A	G	G	G	G	Tape Reel
LR3965L-xx-S08-T	LR3965G-xx-S08-T	SOP-8	S	I	O	A	G	G	G	G	Tube

Note: Pin Assignment: I:V<sub>IN</sub> O:V<sub>OUT</sub> G:GND S: SHDN A: ADJ/SENSE/SS/POK

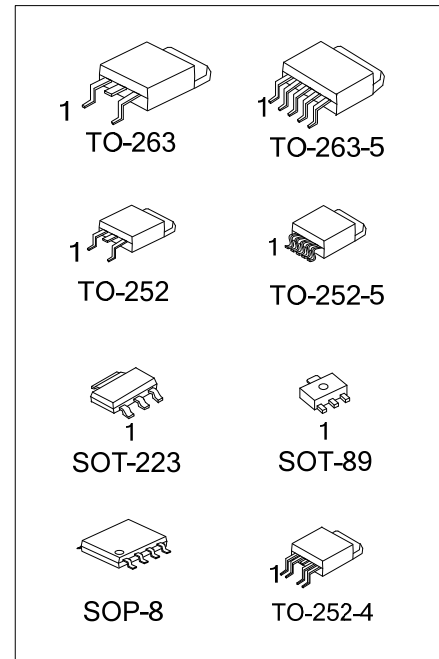

## ORDERING INFORMATION(Cont.)

<p>LR3965L-xx-AA3-D-R</p> <p>(1)Packing Type (2)Pin Assignment (3)Package Type (4)Output Voltage Code (5)Lead Free</p>	<p>(1) R: Tape Reel, T: Tube (2) refer to Pin Assignment (3) AA3: SOT-223, AB3: SOT-89, TN3: TO-252 TN4: TO-252-4, TN5: TO-252-5, TQ2: TO-263, TQ5-TO-263-5, S08: SOP-8 (4) xx: refer to Marking Information (5) G: Halogen Free, L: Lead Free</p>
--	--

## MARKING INFORMATION

PACKAGE	VOLTAGE CODE	MARKING
SOT-223		
SOT-89	12 :1.2V 15 :1.5V 18 :1.8V 25 :2.5V 33 :3.3V 50 :5.0V	
TO-252 TO-263		
TO-252-4 TO-252-5 TO-263-5	12 :1.2V 15 :1.5V 18 :1.8V 25 :2.5V 33 :3.3V 50 :5.0V	
SOP-8	12 :1.2V 15 :1.5V 18 :1.8V 25 :2.5V 33 :3.3V 50 :5.0V AD :ADJ	

## ■ PIN CONFIGURATION

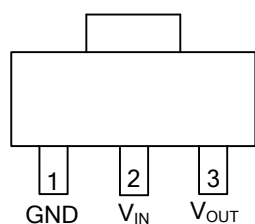

SOT-89

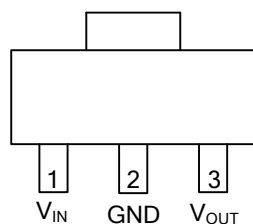

SOT-223

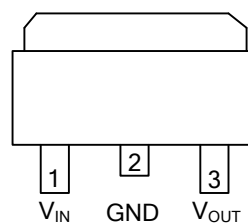

TO-252/TO-263

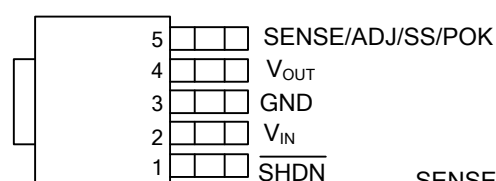

TO-252-4/TO-252-5/TO-263-5

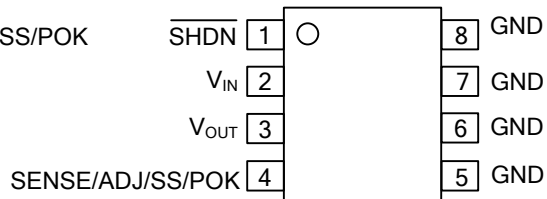

SOP-8

## ■ PIN DESCRIPTION

PIN NAME	DESCRIPTION
$V_{IN}$	Power Input Voltage. Supply voltage can range from 2.25V to 6V. Bypass with a 68 $\mu$ F capacitor to GND.
GND	Ground
$\overline{\text{SHDN}}$	Active-Low Shutdown Input. A logic low at $\overline{\text{SHDN}}$ reduces supply current to 0.01 $\mu$ A. In shutdown, the POK output is low. Connect $\overline{\text{SHDN}}$ to $V_{IN}$ for normal operation.
$V_{OUT}$	Output Voltage
ADJ	Voltage-adjust Input. Connect ADJ to GND for preset output. Connect an external resistive voltage-divider from $V_{OUT}$ to ADJ to set the output voltage between 0.8V and 6V. The ADJ regulation voltage is 800mV
SENSE	Remote sense pin.
SS	Soft start time setting. For adjustable soft start time version, connect a capacitor from SS to gnd to set the soft start time.
POK	Open-Drain, Active-Low Power-OK Output. POK remains low while the output voltage ( $V_{OUT}$ ) is below the POK threshold.

## ■ BLOCK DIAGRAM

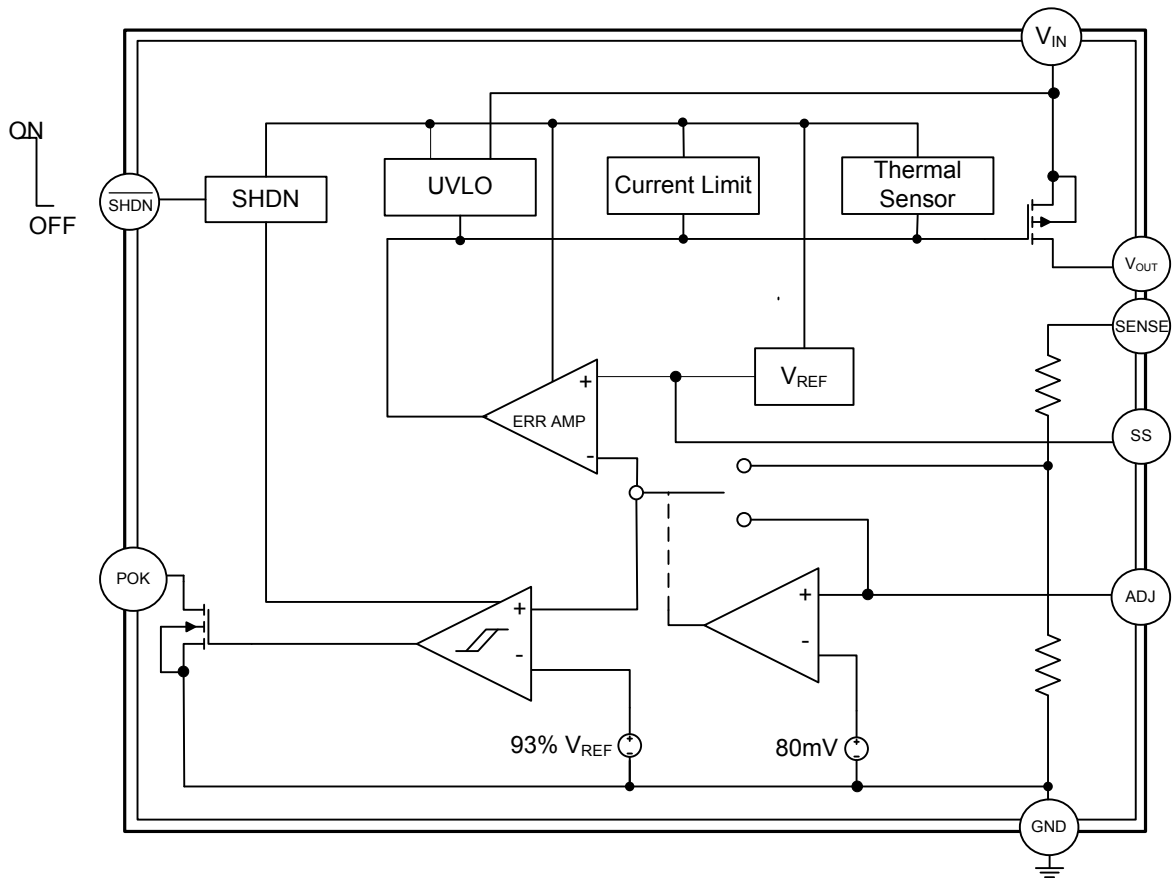

■ **ABSOLUTE MAXIMUM RATING** ( $T_A=25^{\circ}\text{C}$ , unless otherwise specified)

PARAMETER		SYMBOL	RATINGS	UNIT
Supply Voltage		$V_{IN}$	6.5	V
Power Dissipation	SOP-8	$P_D$	606	mW
	SOT-223		714	
	SOT-89		500	
	TO-252/TO-252-5/TO-252-4		952	
	TO-263/TO-263-5		1250	
Junction Temperature		$T_J$	+125	$^{\circ}\text{C}$
Operating Temperature		$T_{OPR}$	-40 ~ +85	$^{\circ}\text{C}$
Storage Temperature		$T_{STG}$	-65 ~ +150	$^{\circ}\text{C}$

Note: Absolute maximum ratings are those values beyond which the device could be permanently damaged.

Absolute maximum ratings are stress ratings only and functional device operation is not implied.

■ **THERMAL DATA**

PARAMETER		SYMBOL	RATINGS	UNIT
Junction to Ambient	SOP-8	$\theta_{JA}$	165	$^{\circ}\text{C/W}$
	SOT-223		150	
	SOT-89		180	
	TO-252/TO-252-5/TO-252-4		112	
	TO-263/TO-263-5		64	
Junction to Case	SOP-8	$\theta_{JC}$	20	$^{\circ}\text{C/W}$
	SOT-223		15	
	SOT-89		50	
	TO-252/TO-252-5/TO-252-4		12	
	TO-263/TO-263-5		4	

## ■ ELECTRICAL CHARACTERISTICS

( $T_A = 25^\circ\text{C}$ ,  $V_{IN} = V_{OUT} + 1\text{V}$  or  $V_{IN} = 2.25\text{V}$  whichever is greater,  $C_{IN} = 68\mu\text{F}$ ,  $C_{OUT} = 33\mu\text{F}$ , unless otherwise specified)

PARAMETER	SYMBOL	TEST CONDITIONS	MIN	TYP	MAX	UNIT
Input Voltage	$V_{IN}$		Note1		6	V
Output Voltage Accuracy (Preset Mode)	$V_{OUT}$	$T_A = 25^\circ\text{C}$ , $I_{OUT} = 1\text{mA} \sim 1.5\text{A}$	-2		2	%
		$T_A = 0 \sim 85^\circ\text{C}$ , $I_{OUT} = 1\text{mA} \sim 1.5\text{A}$	-3		3	%
Maximum Output Current	$I_{OUT}$			1.5		A
Short-Circuit Current Limit	$I_{LIMIT}$	$V_{OUT} = 0\text{V}$		2.5		A
Ground Pin Current	$I_{GND}$	$I_{OUT} = 0\text{mA}$		200		$\mu\text{A}$
		$I_{OUT} = 1\text{mA}$ to $1.5\text{A}$		250		$\mu\text{A}$
Dropout Voltage (Note 2)	$V_D$	$I_{OUT} = 1.5\text{A}$	$V_{OUT(NOM)} \leq 1.8\text{V}$	1000	1050	mV
			$1.8\text{V} < V_{OUT(NOM)}$		550	
Line Regulation (Note 3)	$\frac{\Delta V_{OUT}}{\Delta V_{IN} \times V_{OUT}}$	$V_{IN} = V_{OUT} + V_D \sim 6\text{V}$		0.08	0.55	%/V
Load Regulation (Note 3, 4)	$\Delta V_{OUT}$	$V_{IN} = V_{OUT} + V_D$ , $I_{OUT} = 10\text{mA} \sim 1.5\text{A}$		0.25	0.5	%
Output Voltage Noise	$e_N$	$f = 10\text{Hz}$ to $1\text{MHz}$ , $C_{OUT} = 33\mu\text{F}$		300		$\mu\text{V}_{RMS}$
Shutdown Supply Current	$I_{OFF}$	$\overline{\text{SHDN}} = \text{GND}$		0.01	5	$\mu\text{A}$
Shutdown Threshold	$V_{IH}$		1.6			V
	$V_{IL}$				0.6	V
Thermal Shutdown Temperature	$T_{SHDN}$			170		$^\circ\text{C}$
Thermal Shutdown Hysteresis	$DT_{SHDN}$			20		$^\circ\text{C}$
ADJ Voltage	$V_{REF}$	Measured on ADJ, $I_{OUT} = 10\text{mA}$	0.774	0.8	0.826	V
ADJ Mode Threshold				80		mV
Adjustable Output Voltage			0.8		5	V
POK Output Low Voltage	$V_{OL}$	Sinking 2mA		5	50	mV
Operating Voltage Range for Valid POK Output		Sinking $100\mu\text{A}$	1.0		5.5	V
POK Output High Leakage Current		$V_{POK} = 5.5\text{V}$			100	nA
POK Threshold		Rising edge, referred to $V_{OUT(NOM)}$	90	93	96	%

Note 1: The minimum operating value for  $V_{IN}$  is equal to either  $[V_{OUT(NOM)} + V_D]$  or  $2.25\text{V}$ , whichever is greater

2: Dropout voltage is defined as the voltage from the input to output when output is 2% below the nominal value.

3: Output voltage line regulation is defined as the change in output voltage from the nominal value resulting from a change in the input line voltage. Output voltage load regulation is defined as the change in output voltage from the nominal value as the load current increases from no load to full load.

4: Regulation is measured at constant junction temperature by using a 20ms current pulse. Devices are tested for load regulation in the load range from 10mA to 1.5A

■ TYPICAL APPLICATION CIRCUIT

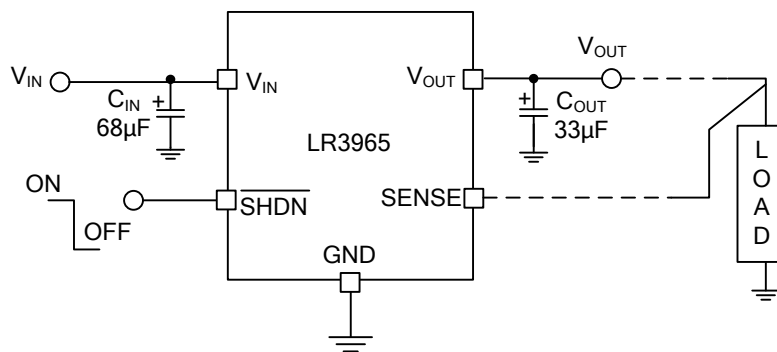
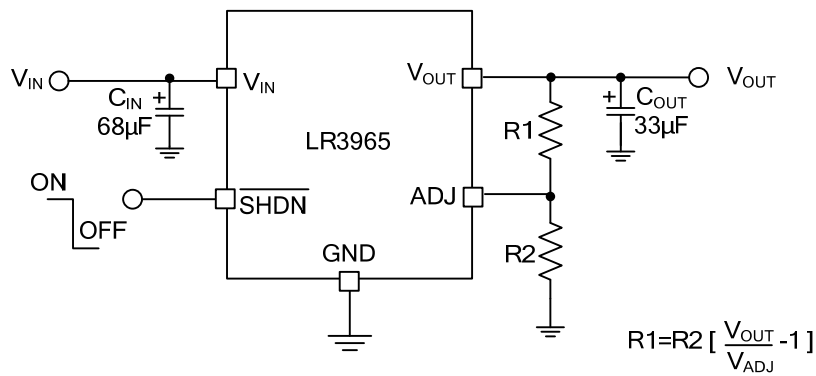
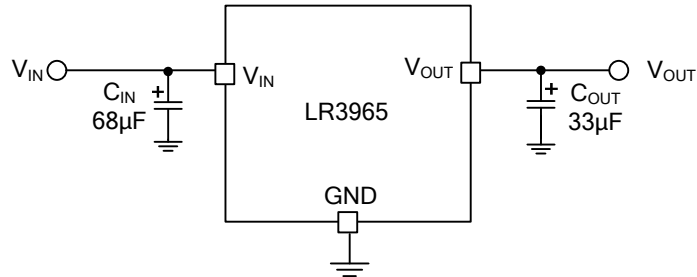

## ■ TYPICAL APPLICATION CIRCUIT (Cont.)

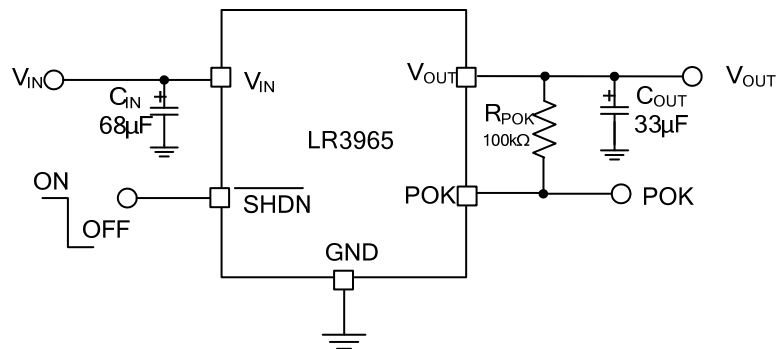
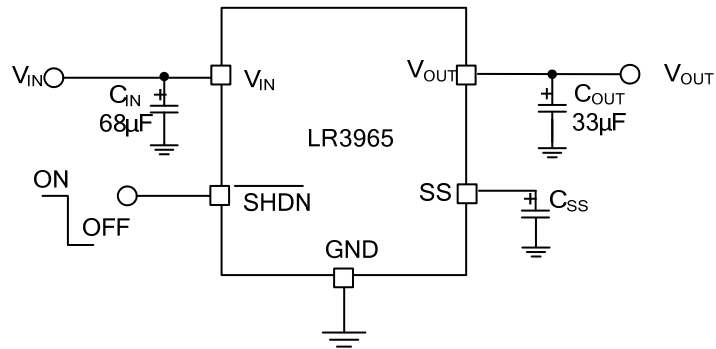

## TYPICAL CHARACTERISTICS

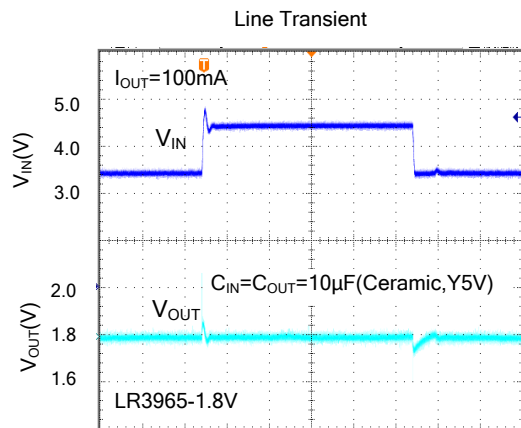
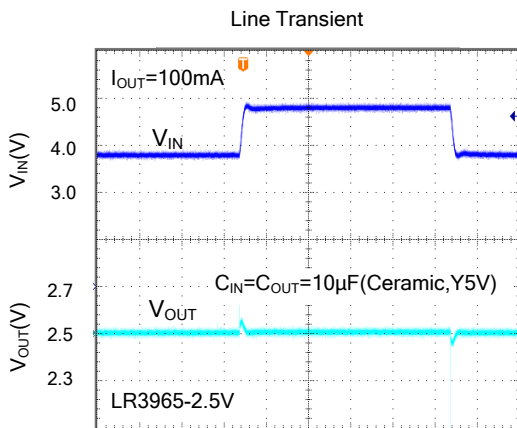
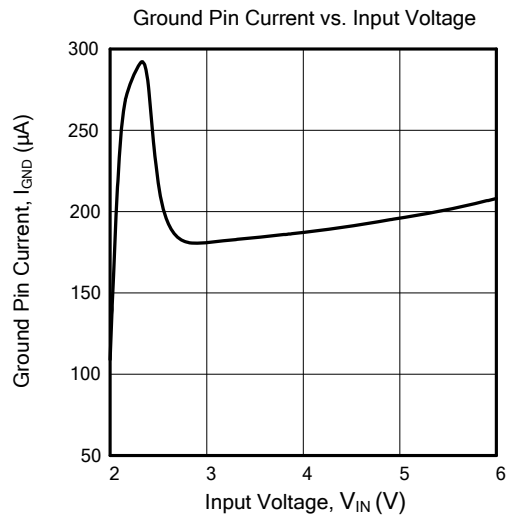
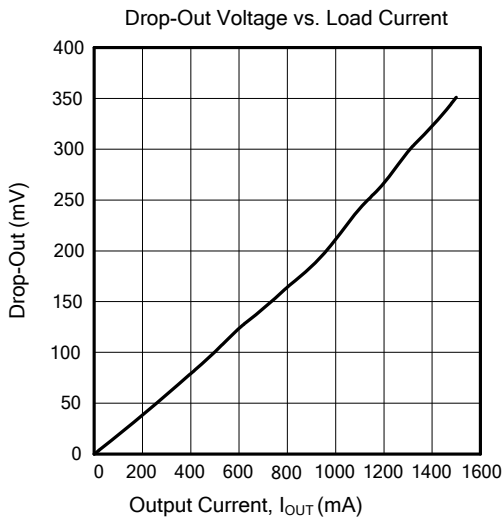
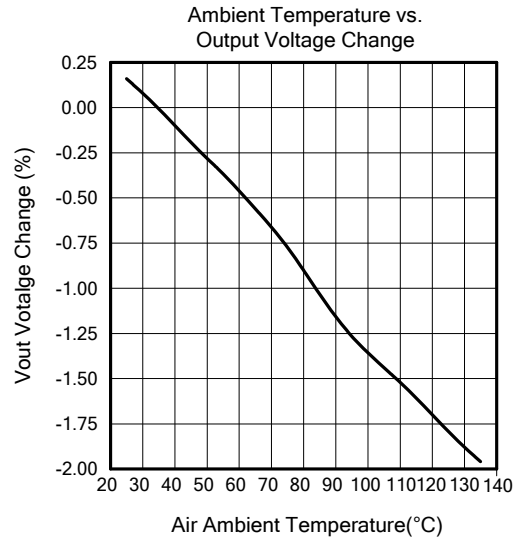
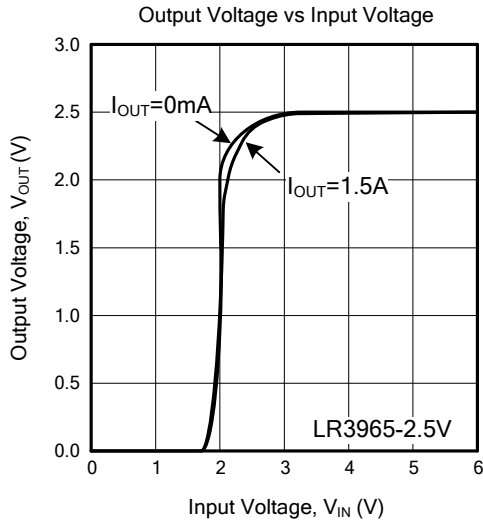

■ TYPICAL CHARACTERISTICS (Cont.)

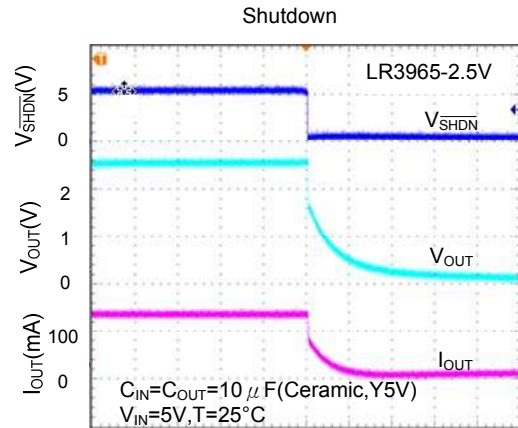
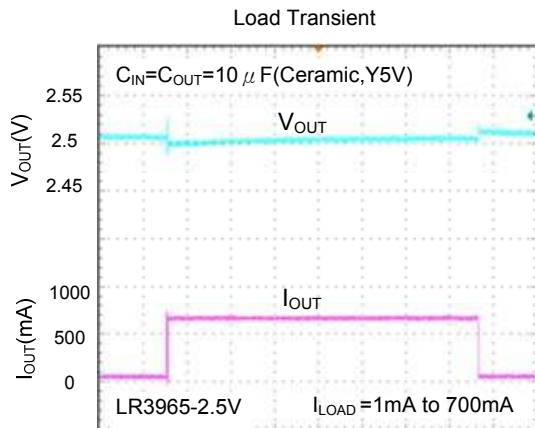

UTC assumes no responsibility for equipment failures that result from using products at values that exceed, even momentarily, rated values (such as maximum ratings, operating condition ranges, or other parameters) listed in products specifications of any and all UTC products described or contained herein. UTC products are not designed for use in life support appliances, devices or systems where malfunction of these products can be reasonably expected to result in personal injury. Reproduction in whole or in part is prohibited without the prior written consent of the copyright owner. The information presented in this document does not form part of any quotation or contract, is believed to be accurate and reliable and may be changed without notice.