



# M2950/2951

## LINEAR INTEGRATED CIRCUIT

### 200mA LOW-DROPOUT VOLTAGE REGULATOR

#### DESCRIPTION

The UTC **M2950/2951** is a monolithic integrated voltage regulator with low dropout voltage, and low quiescent current. It includes many features that suitable for different applications.

#### FEATURES

- \* Fixed output versions, 2.5V, 3V, 3.3V, 3.6V and 5V, are available.
- \* Extremely low quiescent current and dropout voltage.
- \* Extremely tight load and line regulation.
- \* Current and thermal limiting.
- \* Very low temperature coefficient.
- \* Logic controlled shutdown and err flog available for 8 pin package.
- \* Output voltage programmable for M2951

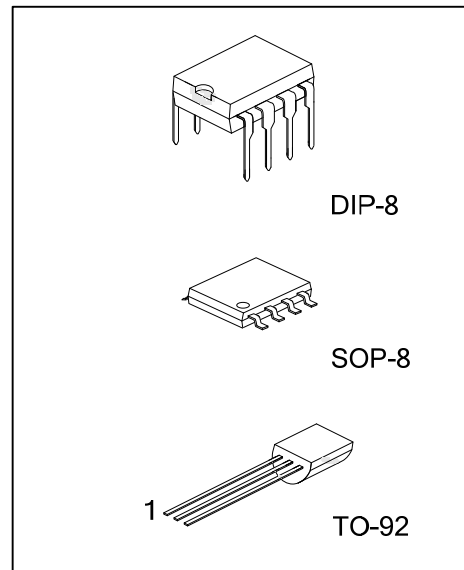

#### ORDERING INFORMATION

Ordering Number		Package	Packing
Lead Free	Halogen Free		
M2950L-xx-D08-T	M2950G-xx-D08-T	DIP-8	Tube
M2950L-xx-S08-T	M2950G-xx-S08-T	SOP-8	Tube
M2950L-xx-S08-R	M2950G-xx-S08-R	SOP-8	Tape Reel
M2950L-xx-T92-B	M2950G-xx-T92-B	TO-92	Tape Box
M2950L-xx-T92-K	M2950G-xx-T92-K	TO-92	Bulk
M2951L-D08-T	M2951G-D08-T	DIP-8	Tube
M2951L-S08-R	M2951G-S08-R	SOP-8	Tape Reel

Note: Pin Assignment: I:V<sub>IN</sub> O:V<sub>OUT</sub> G:GND

<p>M2950L-xx-D08-T</p> <p>(1)Packing Type (2)Package Type (3)Output Voltage Code (4)Lead Free</p>	<p>(1) B: Tape Box, K: Bulk, R: Tape Reel, T: Tube (2) D08: DIP-8, S08: SOP-8, T92: TO-92 (3) xx: refer to Output Voltage Code (4) L: Lead Free, G: Halogen Free</p>
---	--

## MARKING INFORMATION (For LP2950)

PACKAGE	VOLTAGE CODE	MARKING
DIP-8 SOP-8	25: 2.5V 30: 3.0V 33: 3.3V 36: 3.6V 50: 5.0V	
TO-92	25: 2.5V 30: 3.0V 33: 3.3V 36: 3.6V 50: 5.0V	

## PIN CONFIGURATIONS

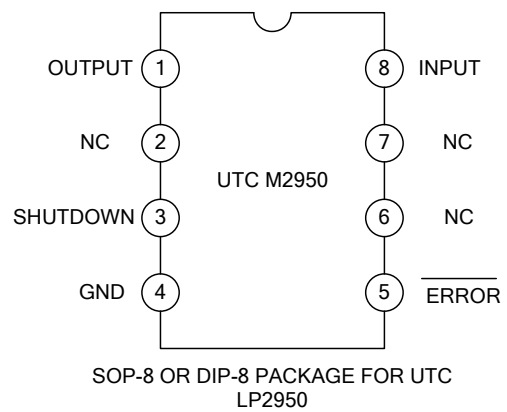
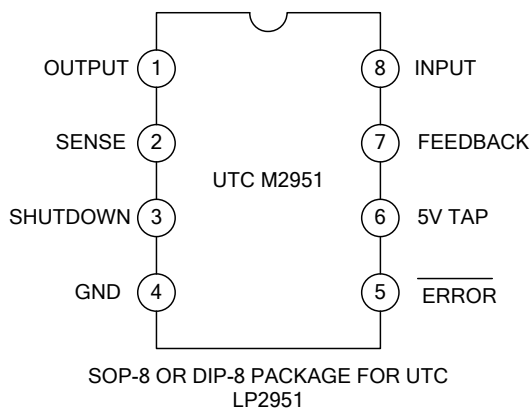
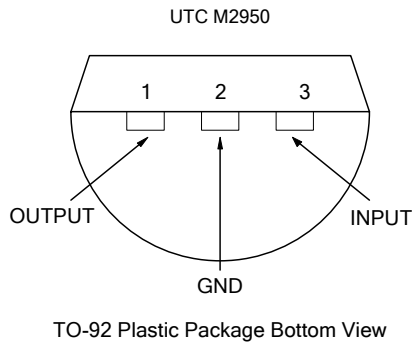

## ■ BLOCK DIAGRAM

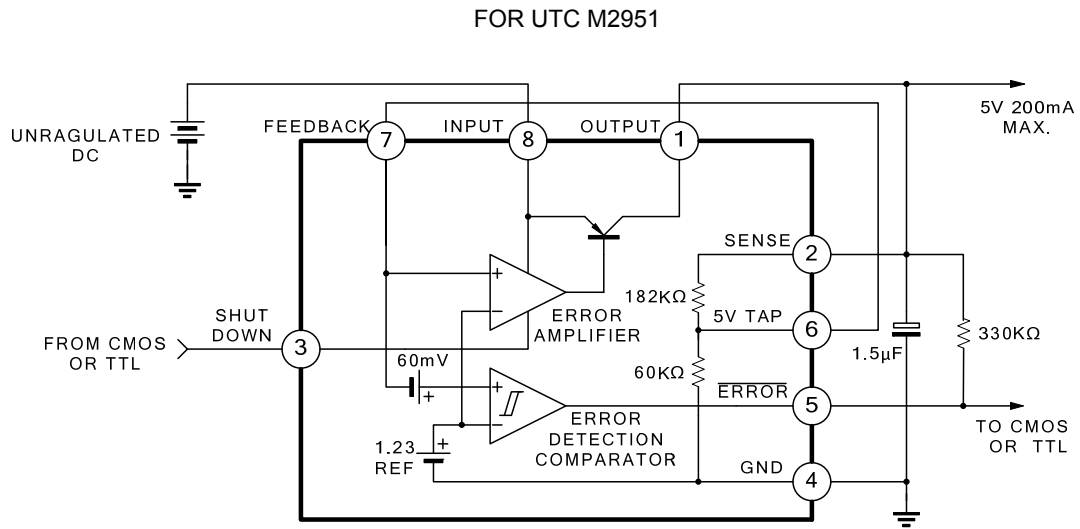

■ **ABSOLUTE MAXIMUM RATINGS** ( $T_J=25^{\circ}\text{C}$ , unless otherwise specified.)

PARAMETER	SYMBOL	RATINGS	UNIT
Supply Voltage	$V_{CC}$	-0.3~+18	V
Feedback Voltage	$V_{FB}$	-1.5~+18	V
Shutdown Voltage	$V_{SHDN}$	-0.3~+18	V
Comparator Output Voltage	$V_{CO}$	-0.3~+18	V
Operation Junction Temperature	$T_J$	-40~+125	$^{\circ}\text{C}$
Storage Temperature	$T_{STG}$	-65~+150	$^{\circ}\text{C}$

Note: Absolute maximum ratings are those values beyond which the device could be permanently damaged. Absolute maximum ratings are stress ratings only and functional device operation is not implied.

■ **THERMAL DATA**

PARAMETER	SYMBOL	RATING	UNIT
Junction to Ambient	TO-92	160	$^{\circ}\text{C/W}$
	SOP-8	180	
	DIP-8	105	
Junction to Case	TO-92	83	$^{\circ}\text{C/W}$
	SOP-8	45	

■ **ELECTRICAL CHARACTERISTICS** ( $T_J=25^{\circ}\text{C}$ ,  $V_{IN}=6\text{V}$ ,  $I_L=100\mu\text{A}$ ,  $C_L=1\mu\text{F}$ , unless otherwise specified.)

**For All Versions:**

PARAMETER	SYMBOL	TEST CONDITION	MIN	TYP	MAX	UNIT
Output Voltage	$V_{OUT}$	$T_J=25^{\circ}\text{C}$ (Note 1)	$V_{OUT}\times 0.98$	$V_{OUT}$	$V_{OUT}\times 1.02$	V
		$-25^{\circ}\text{C}\leq T_J\leq +85^{\circ}\text{C}$ (Note 1)	$V_{OUT}\times 0.98$	$V_{OUT}$	$V_{OUT}\times 1.02$	V
Output Voltage	$V_{OUT}$	$100\mu\text{A}\leq I_L\leq 200\text{mA}$ , $T_J\leq T_{J(MAX)}$	$V_{OUT}\times 0.98$	$V_{OUT}$	$V_{OUT}\times 1.02$	V
Output Voltage Temperature Coefficient	$TcV_o$		20		100	ppm/ $^{\circ}\text{C}$
Line Regulation	$\Delta V_{OUT}$	$6\text{V}\leq V_{IN}\leq 18\text{V}$	0.03	0.1	0.2	%
Load Regulation	$\Delta V_{OUT}$	$100\mu\text{A}\leq I_L\leq 200\text{mA}$	0.04	0.1	0.2	%
Dropout Voltage	$V_D$	$I_L=100\mu\text{A}$	50	80	150	mV
		$I_L=200\text{mA}$ (Note 2)	380	450	600	
Ground Current	$I_G$	$I_L=100\mu\text{A}$	75	120	140	$\mu\text{V}$
		$I_L=200\text{mA}$	8	12	22	mA
Dropout Ground Current		$V_{IN}=4.5\text{V}$ , $I_L=100\mu\text{A}$	110	170	200	$\mu\text{V}$
Current Limit	$I_{LIMIT}$	$V_{OUT}=0\text{V}$	200		420	mA
Output Noise (10Hz ~ 100KHz) (Bypass=0.01 $\mu\text{F}$ pins 7 to 1 (UTC M2951))	eN	$C_L=1\mu\text{F}$	260	280	430	$\mu\text{V}$
		$C_L=200\mu\text{F}$			160	
		$C_L=3.3\mu\text{F}$			100	

### ■ ELECTRICAL CHARACTERISTICS (Cont.)

#### For UTC M2951 8-Pin Version Only

PARAMETER	SYMBOL	TEST CONDITION	MIN	TYP	MAX	UNIT	
<b>ERROR COMPARATOR</b>							
Output Leakage Current	$I_{O(LEAK)}$	$V_{OH}=18V$			1	$\mu A$	
Output Low Voltage	$V_{OL}$	$V_{IN}=V_{OUT}\times 90\%$ , $I_{OL}=400\mu A$			250	mV	
Threshold Voltage	Upper	$V_{THU}$ (Note 3)	3.2		7.6	%VO	
	Lower						$V_{THL}$
Hysteresis	$V_{HYS}$	(Note 3)		15		mV	
<b>SHUTDOWN INPUT</b>							
Input Logic Voltage	Low	$V_{IL}$	Regulator ON		1.3	0.7	V
	High	$V_{IH}$	Regulator OFF	2.0			
Shutdown Pin Input Current		$I_{SHDN}$	$V_{SHDN}=2.4V$		30	50	$\mu A$
			$V_{SHDN}=18V$		450	600	
Regulator Output Current Shutdown	$I_{OFF}$	$V_{SHDN}\geq 2V$ , $V_{IN}\leq 18V$ , $V_{OUT}=0V$ Feedback pin tied to 5V Tap.		3	10	$\mu A$	

#### For UTC M2951 8-Pin Version Only

PARAMETER	SYMBOL	TEST CONDITION	MIN	TYP	MAX	UNIT
Reference Voltage	$V_{REF}$	$V_{OH}=18V$	1.22	1.235	1.25	V
Reference Voltage	$V_{REF}$	Over temperature(Note 4)	1.19		1.27	V
Feedback pin Bias Current	$I_{FB}$			20	40	nA
Reference Voltage Temperature Coefficient	$V_{REF(TC)}$			50		ppm/ $^{\circ}C$
Feedback Bias Current Temperature Coefficient	$I_{FB(TC)}$			0.1		nA/ $^{\circ}C$

Note: 1. Additional conditions for 8-pin versions are feedback tied to 5V Tap an Output tied to Output Sense ( $V_{OUT}=5V$ ) and  $V_{SHDN}\leq 0.8V$ .

2. Dropout Voltage is defined as the input to output differential at which the output voltage drops 100mV below its nominal value measured at 1V differential.

3. Comparator thresholds are expressed in terms of percentage value of voltage output.

4.  $V_{REF}\leq V_{OUT}\leq (V_{IN}-1V)$ ,  $2.3V\leq V_{IN}\leq 30V$ ,  $100\mu A\leq I_L\leq 250mA$ ,  $T_J\leq T_{J(MAX)}$

## ■ APPLICATION CIRCUIT

### 10 Ampere Low Dropout Regulator

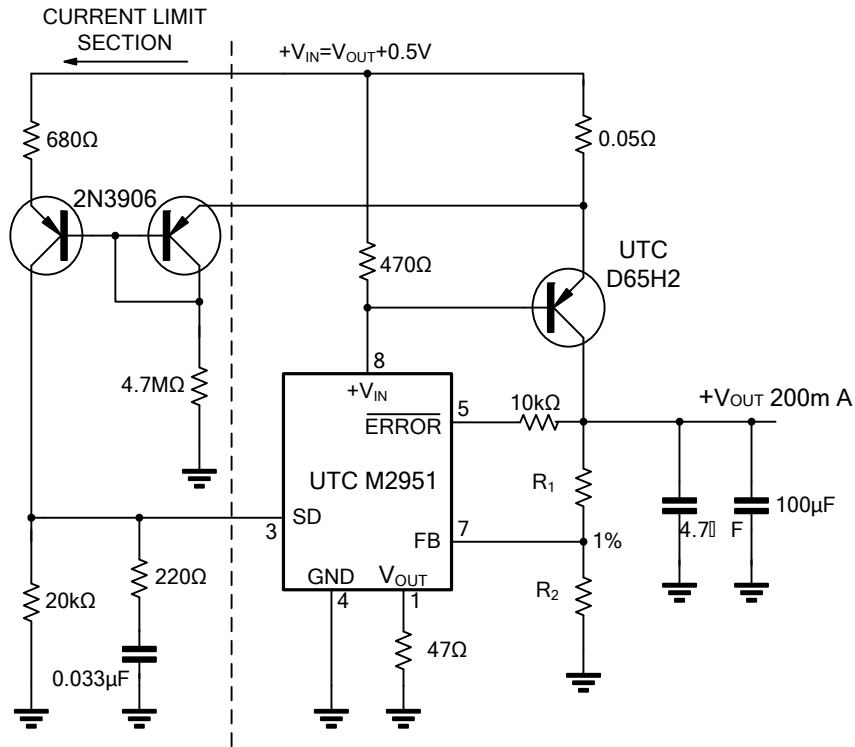

$$V_{OUT} = 1.23V * (1 + R_1/R_2)$$

For 5V output use internal resistors. Wire pin 6 to 7 and wire pin 2 to +V<sub>OUT</sub>

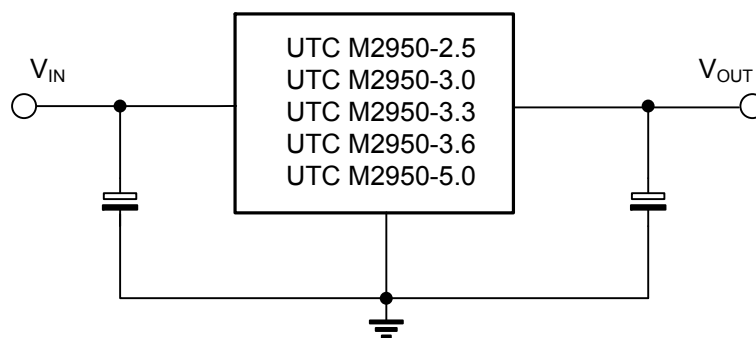

## ■ TYPICAL CHARACTERISTICS

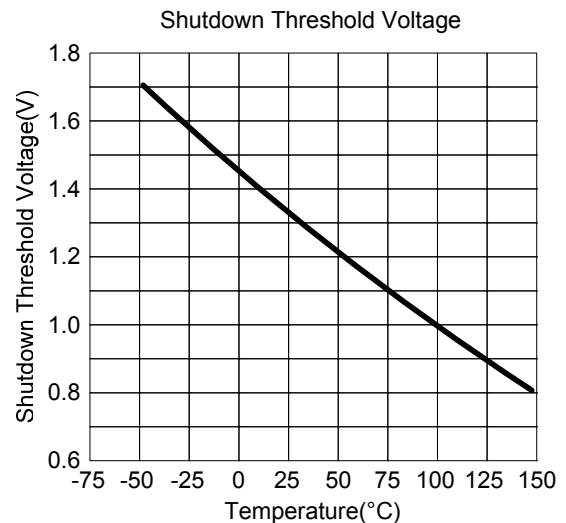
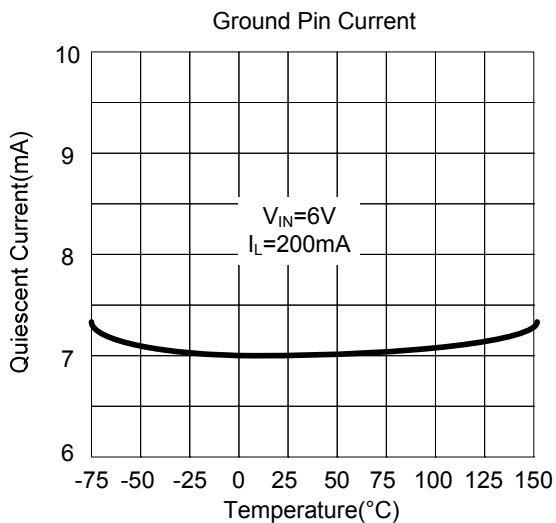
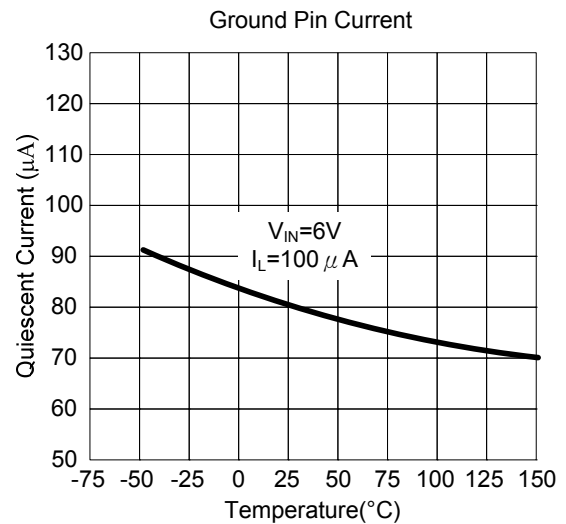
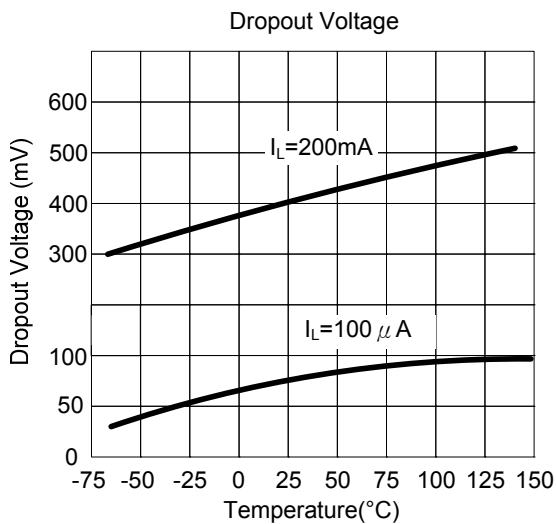
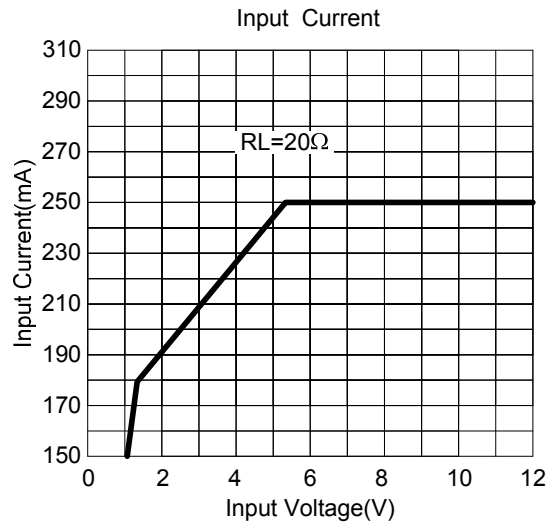
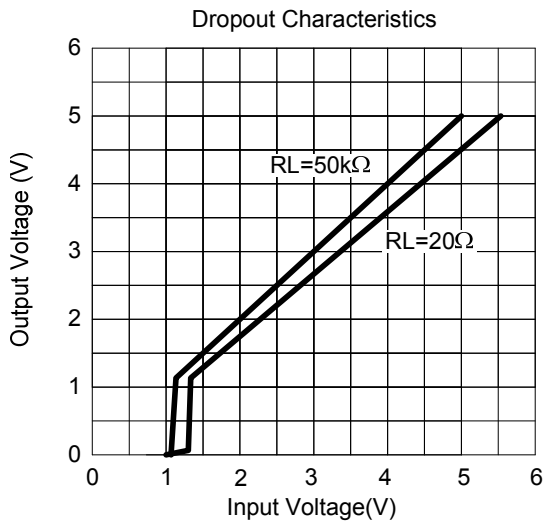

## ■ TYPICAL CHARACTERISTICS(Cont.)

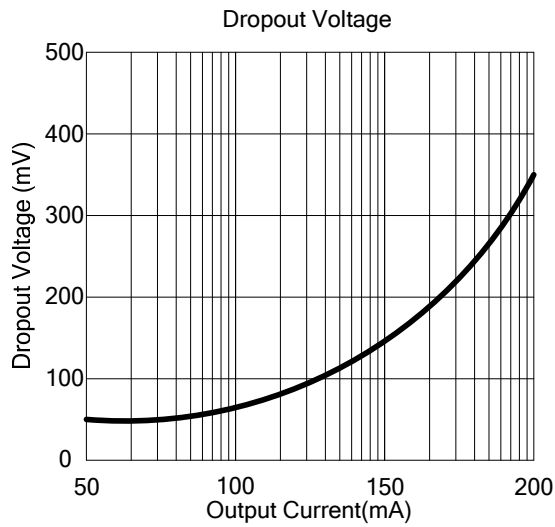

UTC assumes no responsibility for equipment failures that result from using products at values that exceed, even momentarily, rated values (such as maximum ratings, operating condition ranges, or other parameters) listed in products specifications of any and all UTC products described or contained herein. UTC products are not designed for use in life support appliances, devices or systems where malfunction of these products can be reasonably expected to result in personal injury. Reproduction in whole or in part is prohibited without the prior written consent of the copyright owner. The information presented in this document does not form part of any quotation or contract, is believed to be accurate and reliable and may be changed without notice.