



79TXXA

LINEAR INTEGRATED CIRCUIT

3 TERMINAL 1A NEGATIVE VOLTAGE REGULATOR

DESCRIPTION

The UTC 79TXXA series of three-terminal negative regulators are available in TO-263 package and with several fixed output voltage, making them useful in a wide range of application. Each type employs internal current limiting, thermal shut-down and safe area protection, making it essentially indestructible.

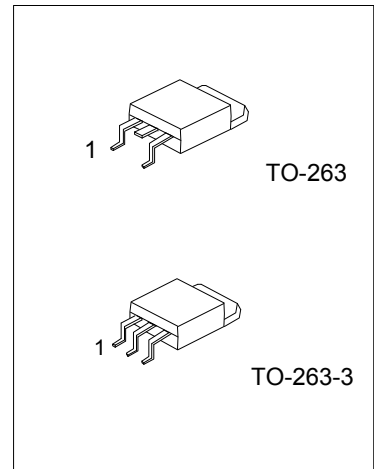

FEATURES

- *Output current up to 1A
- *-5V, -6V, -8V, -9V, -12V, -15V, -18V, -24V output voltage available
- *Thermal overload protection
- *Short circuit protection

ORDERING INFORMATION

Ordering Number		Package	Pin Assignment			Packing
Lead Free	Halogen Free		1	2	3	
79TXXAL-TQ2-R	79TXXAG-TQ2-R	TO-263	G	I	O	Tape Reel
79TXXAL-TQ2-T	79TXXAG-TQ2-T	TO-263	G	I	O	Tube
79TXXAL-TQ3-R	79TXXAG-TQ3-R	TO-263-3	G	I	O	Tape Reel
79TXXAL-TQ3-T	79TXXAG-TQ3-T	TO-263-3	G	I	O	Tube

Note: Pin Code: I: Input G: GND O: Output

<p>79TXXAL-TQ2-R</p>	<p>(1) R: Tape Reel, T: Tube</p> <p>(2) TO-263: TQ2, TO-263-3: TQ3</p> <p>(3) G: Halogen Free, L: Lead Free</p> <p>(4) XX: refer to Marking Information</p>
----------------------	---

MARKING INFORMATION

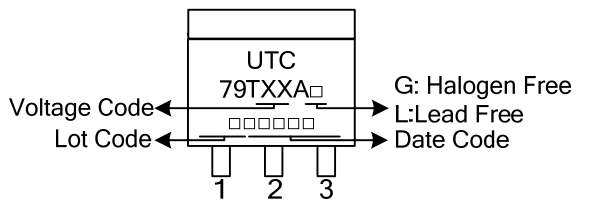
PACKAGE	VOLTAGE CODE	MARKING
TO-263 TO-263-3	05 :5.0V 06 :6.0V 08 :8.0V 09 :9.0V 12 :12V 15 :15V 18 :18V 24 :24V	 <p> UTC 79TXXA□ □□□□□□ 1 2 3 </p> <p> Voltage Code ← Lot Code ← </p> <p> G: Halogen Free L: Lead Free Date Code </p>

BLOCK DIAGRAM

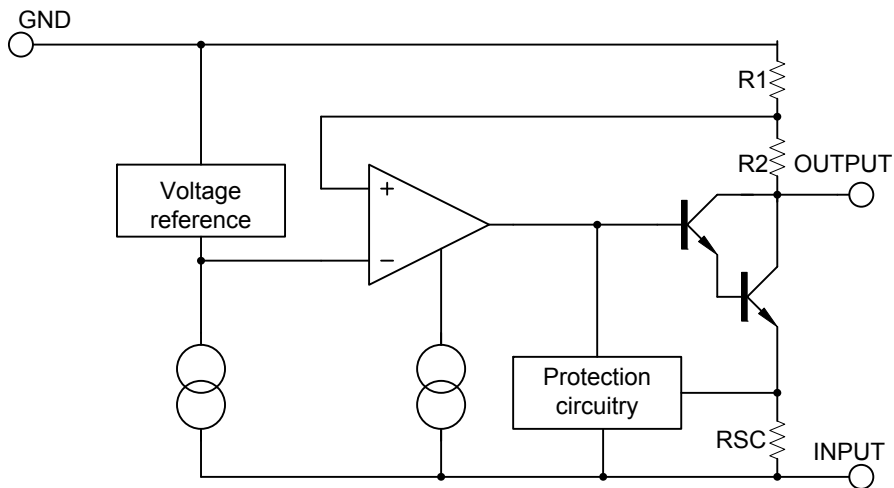

■ ABSOLUTE MAXIMUM RATINGS (T_A=25°C, unless otherwise specified)

PARAMETER	SYMBOL	RATING	UNIT
Input voltage	V _{IN}	-35	V
Output Current	I _{OUT}	1	A
Power Dissipation	P _D	Internally Limited	W
Operating Temperature	T _{OPR}	0 ~ +125	°C
Storage Temperature	T _{STG}	-65 ~ +150	°C

Note: Absolute maximum ratings are those values beyond which the device could be permanently damaged.

Absolute maximum ratings are stress ratings only and functional device operation is not implied.

■ THERMAL DATA

PARAMETER	SYMBOL	RATINGS	UNIT
Junction to Ambient	θ _{JA}	65	°C/W
Junction to Case	θ _{JC}	5	°C/W

■ ELECTRICAL CHARACTERISTICS

(Refer to test circuits, T_J= 0°C-125°C, I_{OUT}=500mA, C_O=1uF, unless otherwise specified)

FOR 79T05A (V_{IN} = -10V, C_I = 33uF)

PARAMETER	SYMBOL	TEST CONDITIONS	MIN	TYP	MAX	UNIT
Output Voltage	V _{OUT}	T _J =25°C	-4.80	-5.0	-5.20	V
		I _{OUT} =5mA ~ 1A, P _D ≤ 15W, V _{IN} = -7V ~ -20V	-4.75		-5.25	V
Line Regulation	ΔV _{OUT}	T _J =25°C, V _{IN} = -7V ~ -25V		10	100	mV
		T _J =25°C, V _{IN} = -8V ~ -12V				mV
Load Regulation	ΔV _{OUT}	T _J =25°C, I _{OUT} = 5mA ~ 1A		10	100	mV
		T _J =25°C, I _{OUT} = 250mA ~ 750mA		3	50	mV
Quiescent Current	I _Q	T _J =25°C		3	6	mA
Quiescent Current Change	ΔI _Q	I _{OUT} = 5mA ~ 1A		0.05	0.5	mA
		V _{IN} = -7V ~ -25V		0.1	1.3	mA
Temperature coefficient of V _O	ΔV _O /ΔT	I _{OUT} = 5mA		-0.4		mV/°C
Output Noise Voltage	eN	f=10Hz ~ 100kHz, T _A =25°C		100		μV
Ripple Rejection	RR	f=120Hz, V _{IN} = -8V ~ -18V	54	60		dB
Dropout Voltage	V _D	I _{OUT} = 1.0A, T _J =25°C		2		V
Short-Circuit Current	I _{SC}	V _{IN} = -35V, T _A =25°C		300		mA
Peak Output Current	I _{PEAK}	T _J =25°C		2.2		A

FOR 79T06A (V_{IN} = -11V, C_I = 2.2uF)

PARAMETER	SYMBOL	TEST CONDITIONS	MIN	TYP	MAX	UNIT
Output Voltage	V _{OUT}	T _J =25°C	-5.76	-6.00	-6.24	V
		I _{OUT} =5mA ~ 1A, P _D ≤ 15W, V _{IN} = -8V ~ -21V	-5.70		-6.30	V
Line Regulation	ΔV _{OUT}	T _J =25°C, V _{IN} = -8V ~ -25V		10	120	mV
		T _J =25°C, V _{IN} = -9V ~ -13V		5	60	mV
Load Regulation	ΔV _{OUT}	T _J =25°C, I _{OUT} = 5mA ~ 1A		10	120	mV
		T _J =25°C, I _{OUT} = 250mA ~ 750mA		3	60	mV
Quiescent Current	I _Q	T _J =25°C		3	6	mA
Quiescent Current Change	ΔI _Q	I _{OUT} = 5mA ~ 1A			0.5	mA
		V _{IN} = -8V ~ -25V			1.3	mA
Temperature coefficient of V _O	ΔV _O /ΔT	I _{OUT} = 5mA		-0.5		mV/°C
Output Noise Voltage	eN	f=10Hz ~ 100kHz, T _A =25°C		130		μV
Ripple Rejection	RR	f=120Hz, V _{IN} = -9V ~ -19V	54	60		dB
Dropout Voltage	V _D	I _{OUT} = 1.0A, T _J =25°C		2		V
Short-Circuit Current	I _{SC}	V _{IN} = -35V, T _A =25°C		300		mA
Peak Output Current	I _{PEAK}	T _J =25°C		2.2		A

■ ELECTRICAL CHARACTERISTICS(Cont.)

FOR 79T08A ($V_{IN} = -14V$, $C_I = 2.2\mu F$)

PARAMETER	SYMBOL	TEST CONDITIONS	MIN	TYP	MAX	UNIT
Output Voltage	V_{OUT}	$T_J = 25^\circ C$	-7.68	-8.0	-8.32	V
		$I_{OUT} = 5mA \sim 1A$, $P_D \leq 15W$, $V_{IN} = -10.5V \sim -23V$	-7.60		-8.40	V
Line Regulation	ΔV_{OUT}	$T_J = 25^\circ C$, $V_{IN} = -10.5V \sim -25V$		10	100	mV
		$T_J = 25^\circ C$, $V_{IN} = -11.5V \sim -17V$		5	80	mV
Load Regulation	ΔV_{OUT}	$T_J = 25^\circ C$, $I_{OUT} = 5mA \sim 1A$		12	160	mV
		$T_J = 25^\circ C$, $I_{OUT} = 250mA \sim 750mA$		4	80	mV
Quiescent Current	I_Q	$T_J = 25^\circ C$		3	6	mA
Quiescent Current Change	ΔI_Q	$I_{OUT} = 5mA \sim 1A$		0.05	0.5	mA
		$V_{IN} = -11.5V \sim -25V$		0.1	1.0	mA
Temperature coefficient of V_O	$\Delta V_O / \Delta T$	$I_{OUT} = 5mA$		-0.6		mV/ $^\circ C$
Output Noise Voltage	eN	$f = 10Hz \sim 100kHz$, $T_A = 25^\circ C$		175		μV
Ripple Rejection	RR	$f = 120Hz$, $V_{IN} = -11.5V \sim -21.5V$	54	60		dB
Dropout Voltage	V_D	$I_{OUT} = 1.0A$, $T_J = 25^\circ C$		2		V
Short-Circuit Current	I_{SC}	$V_{IN} = -35V$, $T_A = 25^\circ C$		300		mA
Peak Output Current	I_{PEAK}	$T_J = 25^\circ C$		2.2		A

FOR 79T09A ($V_{IN} = -15V$, $C_I = 2.2\mu F$)

PARAMETER	SYMBOL	TEST CONDITIONS	MIN	TYP	MAX	UNIT
Output Voltage	V_{OUT}	$T_J = 25^\circ C$	-8.64	-9.0	-9.36	V
		$I_{OUT} = 5mA \sim 1A$, $P_D \leq 15W$, $V_{IN} = -11.5V \sim -23V$	-8.55		-9.45	V
Line Regulation	ΔV_{OUT}	$T_J = 25^\circ C$, $V_{IN} = -11.5V \sim -26V$		10	180	mV
		$T_J = 25^\circ C$, $V_{IN} = -12V \sim -18V$		5	90	mV
Load Regulation	ΔV_{OUT}	$T_J = 25^\circ C$, $I_{OUT} = 5mA \sim 1A$		12	180	mV
		$T_J = 25^\circ C$, $I_{OUT} = 0.25A \sim 0.75A$		4	90	mV
Quiescent Current	I_Q	$T_J = 25^\circ C$		3	6	mA
Quiescent Current Change	ΔI_Q	$I_{OUT} = 5mA \sim 1A$		0.05	0.5	mA
		$V_{IN} = -11.5V \sim -26V$		0.1	1.0	mA
Temperature coefficient of V_O	$\Delta V_O / \Delta T$	$I_{OUT} = 5mA$		-0.6		mV/ $^\circ C$
Output Noise Voltage	eN	$f = 10Hz \sim 100kHz$, $T_A = 25^\circ C$		175		μV
Ripple Rejection	RR	$f = 120Hz$, $T_J = 25^\circ C$, $V_{IN} = -12.5V \sim -22.5V$	54	60		dB
Dropout Voltage	V_D	$I_{OUT} = 1.0A$, $T_J = 25^\circ C$		2.0		V
Short-Circuit Current	I_{SC}	$V_{IN} = -35V$, $T_A = 25^\circ C$		300		mA
Peak Output Current	I_{PEAK}	$T_J = 25^\circ C$		2.2		A

■ ELECTRICAL CHARACTERISTICS(Cont.)

FOR 79T12A ($V_{IN} = -18V$, $C_I = 2.2\mu F$)

PARAMETER	SYMBOL	TEST CONDITIONS	MIN	TYP	MAX	UNIT
Output Voltage	V_{OUT}	$T_J = 25^\circ C$	-11.52	-12.0	-12.48	V
		$I_{OUT} = 5mA \sim 1A$, $P_D \leq 15W$, $V_{IN} = -14.5V \sim -27V$	-11.40		-12.60	V
Line Regulation	ΔV_{OUT}	$T_J = 25^\circ C$, $V_{IN} = -14.5V \sim -30V$		12	240	mV
		$T_J = 25^\circ C$, $V_{IN} = -16V \sim -22V$		6	120	mV
Load Regulation	ΔV_{OUT}	$T_J = 25^\circ C$, $I_{OUT} = 5mA \sim 1A$		12	240	mV
		$T_J = 25^\circ C$, $I_{OUT} = 250mA \sim 750mA$		4	120	mV
Quiescent Current	I_Q	$T_J = 25^\circ C$		3	6	mA
Quiescent Current Change	ΔI_Q	$I_{OUT} = 5mA \sim 1A$		0.05	0.5	mA
		$V_{IN} = -14.5V \sim -30V$		0.1	1.0	mA
Temperature coefficient of V_O	$\Delta V_O / \Delta T$	$I_{OUT} = 5mA$		-0.8		mV/ $^\circ C$
Output Noise Voltage	eN	$f = 10 Hz \sim 100kHz$, $T_A = 25^\circ C$		200		μV
Ripple Rejection	RR	$f = 120Hz$, $V_{IN} = -15V \sim -25V$	54	60		dB
Dropout Voltage	V_D	$I_{OUT} = 1.0A$, $T_J = 25^\circ C$		2		V
Short-Circuit Current	I_{SC}	$V_{IN} = -35V$, $T_A = 25^\circ C$		300		mA
Peak Output Current	I_{PEAK}	$T_J = 25^\circ C$		2.2		A

FOR 79T15A ($V_{IN} = -23V$, $C_I = 2.2\mu F$)

PARAMETER	SYMBOL	TEST CONDITIONS	MIN	TYP	MAX	UNIT
Output Voltage	V_{OUT}	$T_J = 25^\circ C$	-14.40	-15.0	-15.60	V
		$I_{OUT} = 5mA \sim 1A$, $P_D \leq 15W$, $V_{IN} = -17.5V \sim -30V$	-14.25		-15.75	V
Line Regulation	ΔV_{OUT}	$T_J = 25^\circ C$, $V_{IN} = -17.5V$ to $-30V$		12	300	mV
		$T_J = 25^\circ C$, $V_{IN} = -20V$ to $-26V$		6	150	mV
Load Regulation	ΔV_{OUT}	$T_J = 25^\circ C$, $I_{OUT} = 5mA \sim 1A$		12	300	mV
		$T_J = 25^\circ C$, $I_{OUT} = 250mA \sim 750mA$		4	150	mV
Quiescent Current	I_Q	$T_J = 25^\circ C$		3	6	mA
Quiescent Current Change	ΔI_Q	$I_{OUT} = 5mA \sim 1A$		0.05	0.5	mA
		$V_{IN} = -17.5V$ to $-30.5V$		0.1	1.0	mA
Temperature coefficient of V_O	$\Delta V_O / \Delta T$	$I_{OUT} = 5mA$		-0.9		mV/ $^\circ C$
Output Noise Voltage	eN	$f = 10 Hz \sim 100kHz$, $T_A = 25^\circ C$		250		μV
Ripple Rejection	RR	$f = 120Hz$, $V_{IN} = -18.5V$ to $-28.5V$	54	60		dB
Dropout Voltage	V_D	$I_{OUT} = 1.0A$, $T_J = 25^\circ C$		2		V
Short-Circuit Current	I_{SC}	$V_{IN} = -35V$, $T_A = 25^\circ C$		300		mA
Peak Output Current	I_{PEAK}	$T_J = 25^\circ C$		2.2		A

■ ELECTRICAL CHARACTERISTICS(Cont.)

FOR 79T18A ($V_{IN} = -27V$, $C_I = 2.2\mu F$)

PARAMETER	SYMBOL	TEST CONDITIONS	MIN	TYP	MAX	UNIT
Output Voltage	V_{OUT}	$T_J = 25^\circ C$	-17.28	-18.0	-18.72	V
		$I_{OUT} = 5mA \sim 1A$, $P_D \leq 15W$, $V_{IN} = -21V \sim -33V$	-17.10		-18.90	V
Line Regulation	ΔV_{OUT}	$T_J = 25^\circ C$, $V_{IN} = -21V \sim -33V$		15	360	mV
		$T_J = 25^\circ C$, $V_{IN} = -24V \sim -30V$		8	180	mV
Load Regulation	ΔV_{OUT}	$T_J = 25^\circ C$, $I_{OUT} = 5mA \sim 1A$		15	360	mV
		$T_J = 25^\circ C$, $I_O = 250mA \sim 750mA$		5.0	180	mV
Quiescent Current	I_Q	$T_J = 25^\circ C$		3	6	mA
Quiescent Current Change	ΔI_Q	$I_{OUT} = 5mA \sim 1A$			0.5	mA
		$V_{IN} = -21V \sim -32V$			1.0	mA
Temperature coefficient of V_O	$\Delta V_O / \Delta T$	$I_O = 5mA$		-1		mV/ $^\circ C$
Output Noise Voltage	eN	$f = 10Hz \sim 100kHz$, $T_A = 25^\circ C$		300		μV
Ripple Rejection	RR	$f = 120Hz$, $V_{IN} = -22V \sim -32V$	54	60		dB
Dropout Voltage	V_D	$I_O = 1.0A$, $T_J = 25^\circ C$		2		V
Short-Circuit Current	I_{SC}	$V_{IN} = -35V$, $T_A = 25^\circ C$		300		mA
Peak Output Current	I_{PEAK}	$T_J = 25^\circ C$		2.2		A

FOR 79T24A ($V_{IN} = -33V$, $C_I = 2.2\mu F$)

PARAMETER	SYMBOL	TEST CONDITIONS	MIN	TYP	MAX	UNIT
Output Voltage	V_{OUT}	$T_J = 25^\circ C$	-23.04	-24	-24.96	V
		$I_{OUT} = 5mA \sim 1A$, $P_D \leq 15W$, $V_{IN} = -27V \sim -38V$	-22.80		-25.20	V
Line Regulation	ΔV_{OUT}	$T_J = 25^\circ C$, $V_{IN} = -27V \sim -38V$		15	480	mV
		$T_J = 25^\circ C$, $V_{IN} = -30V \sim -36V$		8	240	mV
Load Regulation	ΔV_{OUT}	$T_J = 25^\circ C$, $I_{OUT} = 5mA \sim 1A$		15	480	mV
		$T_J = 25^\circ C$, $I_{OUT} = 250mA \sim 750mA$		5.0	240	mV
Quiescent Current	I_Q	$T_J = 25^\circ C$		3	6	mA
Quiescent Current Change	ΔI_Q	$I_{OUT} = 5mA \sim 1A$			0.5	mA
		$V_{IN} = -27V \sim -38V$			1.0	mA
Temperature coefficient of V_O	$\Delta V_O / \Delta T$	$I_{OUT} = 5mA$		-1		mV/ $^\circ C$
Output Noise Voltage	eN	$f = 10Hz \sim 100kHz$, $T_A = 25^\circ C$		400		μV
Ripple Rejection	RR	$f = 120Hz$, $V_{IN} = -28V \sim -38V$	54	60		dB
Dropout Voltage	V_D	$I_{OUT} = 1.0A$, $T_J = 25^\circ C$		2		V
Short-Circuit Current	I_{SC}	$V_{IN} = -35V$, $T_A = 25^\circ C$		300		mA
Peak Output Current	I_{PEAK}	$T_J = 25^\circ C$		2.2		A

■ APPLICATION CIRCUITS

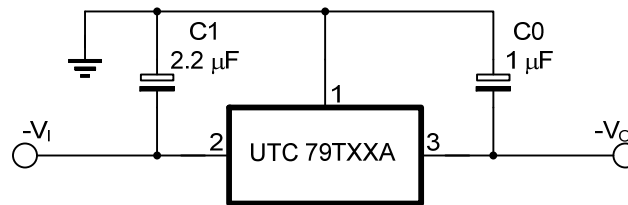

Fig.1 Fixed output regulator

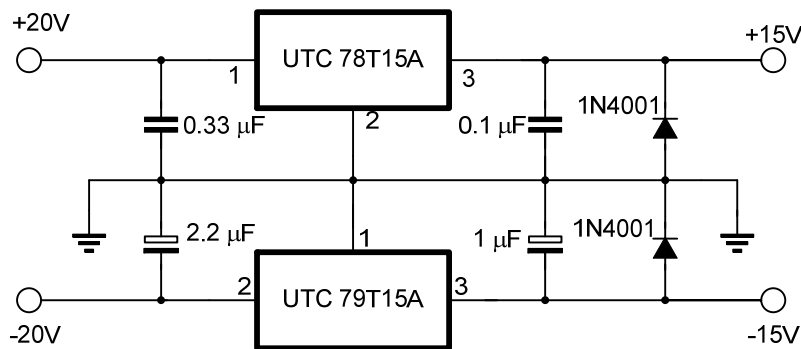

Fig.2 Split power supply (+-15V, 1A)

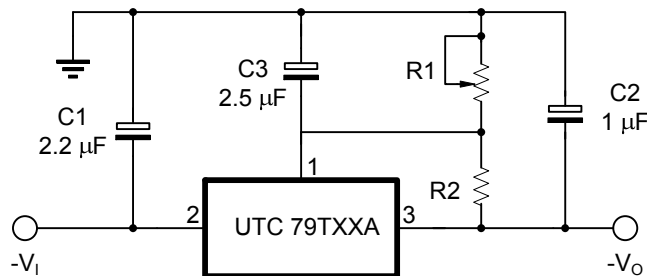

Fig.3 Circuit for increasing output voltage

UTC assumes no responsibility for equipment failures that result from using products at values that exceed, even momentarily, rated values (such as maximum ratings, operating condition ranges, or other parameters) listed in products specifications of any and all UTC products described or contained herein. UTC products are not designed for use in life support appliances, devices or systems where malfunction of these products can be reasonably expected to result in personal injury. Reproduction in whole or in part is prohibited without the prior written consent of the copyright owner. The information presented in this document does not form part of any quotation or contract, is believed to be accurate and reliable and may be changed without notice.