

# SPECIFICATIONS

PARAMETERS	VALUES	UNIT
RATED VOLTAGE	3	Vp-p
OPERATING VOLTAGE RANGE	2 ~ 4	Vp-p
RATED CURRENT (MAX)	70	mA
COIL RESISTANCE	20 ± 3	OHM
MINIMUM SPL @ 10 CM	86	dBA
RESONANT FREQUENCY	2,730 ± 500	Hz
OPERATING TEMPERATURE	-20 ~ +70	°C
STORAGE TEMPERATURE	-30 ~ +80	°C
HOUSING MATERIAL	PBT	-
TERMINAL MATERIAL	Au PLATED PHOSPHOR BRONZE	-
WEIGHT	0.7	grams

THIS DOCUMENT CONTAINS DATA PROPRIETARY TO PROJECTS UNLIMITED, INC. ANY USE OR REPRODUCTION, IN ANY FORM, WITHOUT PRIOR WRITTEN PERMISSION OF PROJECTS UNLIMITED, INC. IS PROHIBITED.  
©2003, Projects Unlimited Inc.

# REVISION HISTORY

LTR	DESCRIPTION	DATE	APPROVED
-	RELEASED FROM ENGINEERING	8/5/2005	
A	REVISED TO INVENTOR 3-D DRAWING TEMPLATE	4/1/2008	B.R.

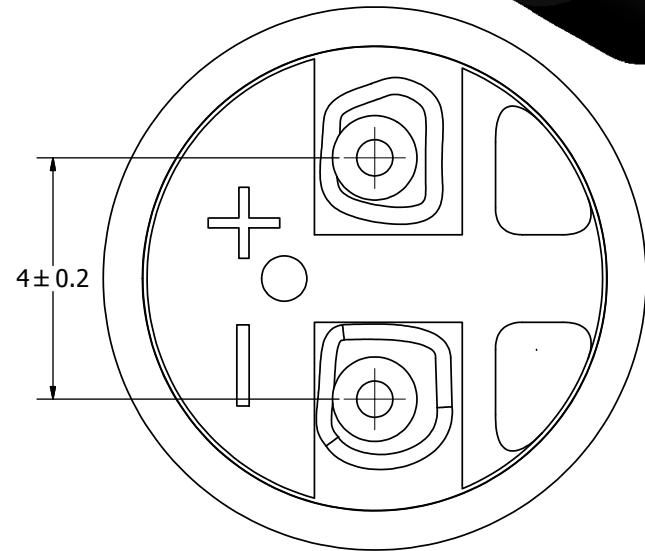
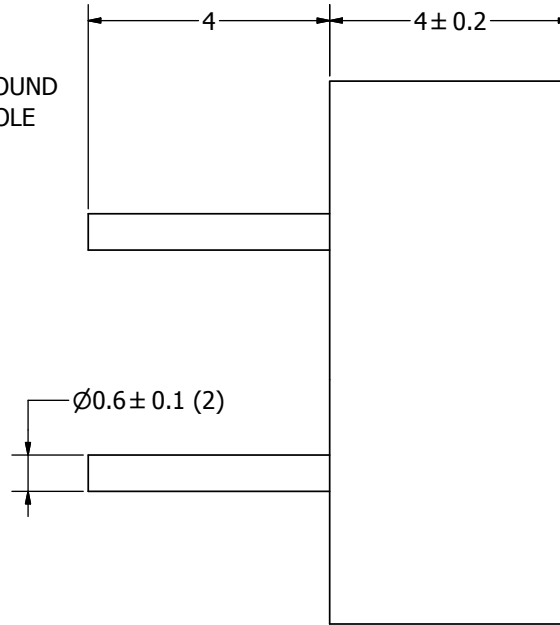
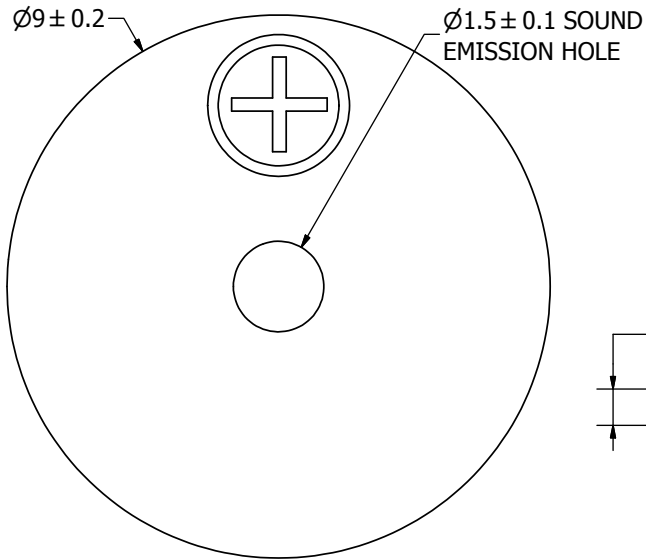
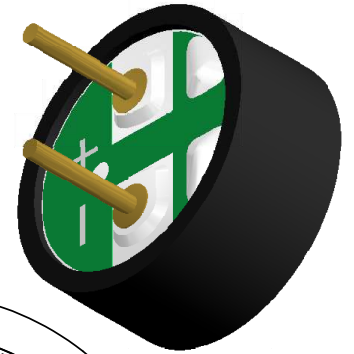

### NOTES:

- ALL DIMENSIONS ARE IN MILLIMETERS.
- SPECIFICATIONS SUBJECT TO CHANGE OR WITHDRAWL WITHOUT NOTICE.
- THIS PART IS RoHS 2002/95/EC COMPLIANT.

UNLESS OTHERWISE SPECIFIED: DIMENSIONS ARE IN MILLIMETERS, TOLERANCES ARE ±0.5 AND ANGLES ARE ±3°.	SIZE <b>A3</b>	Designed by	Date	Checked by	Date	Approved by	Date	Drawn Date
		J.A.F.	8/5/2005	E.P.	8/5/2005	B.R.	8/5/2005	4/1/2008
AT-0927-TT-2-R.idw		 <b>AT-0927-TT-2-R</b> Transducer (Electro-Mech)				Edition	Sheet	
						-	1 / 1	