

| SPECIFICATIONS                                    |             |       |
|---|-------------|-------|
| PARAMETERS  | VALUES      | UNITS |
| RATED INPUT POWER                                 | 0.25        | W     |
| MAX INPUT POWER                                   | 0.5         | W     |
| IMPEDANCE   | 8 ± 15%     | OHM   |
| OUTPUT SPL @ 1W/1M<br>(AT 1.0, 1.2, 1.5, 2.0 kHz) | 88 ± 3      | dB(A) |
| DISTORTION (MAX.)                                 | 5%          | -     |
| RESONANT FREQUENCY                                | 550 ± 20%   | Hz    |
| FREQUENCY RANGE                                   | 550 ~ 3,500 | Hz    |
| HOUSING MATERIAL                                  | METAL       | -     |
| CONE MATERIAL                                     | PAPER       | -     |
| MAGNET MATERIAL                                   | N35         | -     |
| OPERATING TEMPERATURE                             | -20 ~ +55   | °C    |
| WEIGHT  | 52          | grams |

THIS DOCUMENT CONTAINS DATA PROPRIETARY TO PROJECTS UNLIMITED, INC. ANY USE OR REPRODUCTION, IN ANY FORM, WITHOUT PRIOR WRITTEN PERMISSION OF PROJECTS UNLIMITED, INC. IS PROHIBITED.  
©2003, Projects Unlimited Inc.

| REVISION HISTORY |  |           |          |
|------------------|--|-----------|----------|
| LTR              | DESCRIPTION                              | DATE      | APPROVED |
| -                | RELEASED FROM ENGINEERING                | 2/23/2006 |          |
| A                | REVISED TO INVENTOR 3-D DRAWING TEMPLATE | 6/23/2008 | B.R.     |

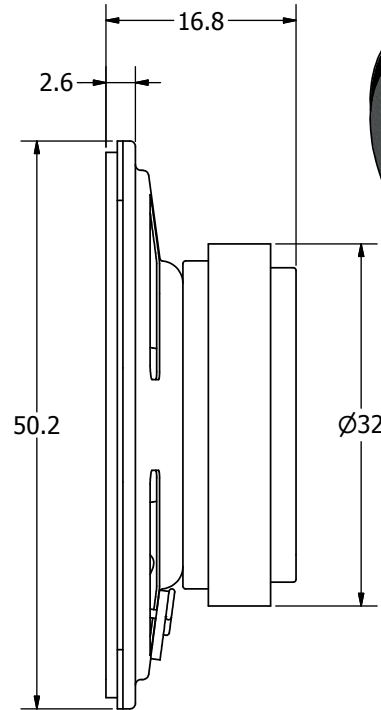
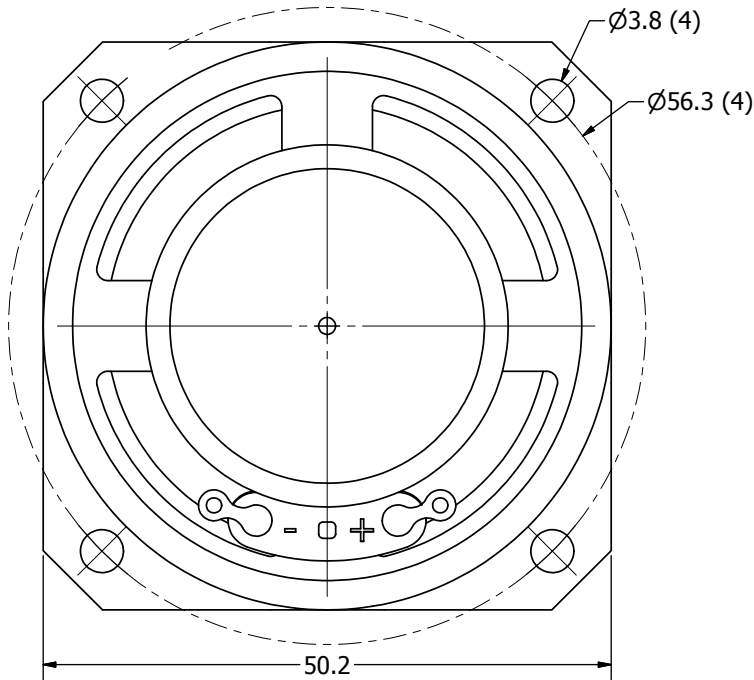

**NOTES:**

1. ALL DIMENSIONS ARE IN MILLIMETERS.
2. SPECIFICATIONS SUBJECT TO CHANGE OR WITHDRAWAL WITHOUT NOTICE.
3. THIS PART IS RoHS 2002/95/EC COMPLIANT.

|  |   |             |             |            |           |             |           |            |
|--|---|-------------|-------------|------------|-----------|-------------|-----------|------------|
| UNLESS OTHERWISE SPECIFIED:<br>DIMENSIONS ARE IN MILLIMETERS,<br>TOLERANCES ARE ±0.5 AND ANGLES ARE ±3°. | SIZE  | Designed by | Date        | Checked by | Date      | Approved by | Date      | Drawn Date |
|  | A3  | J.D.        | 2/22/2006   | E.P.       | 2/22/2006 | B.R.        | 2/22/2006 | 6/23/2008  |
| AS05008PS-R.idw  |  |             | AS05008PS-R |            |           | Speaker     | Edition   | Sheet      |
|  |   |             |             |            |           | -           | 1 / 1     |            |