

PRODUCT DESCRIPTION

The DPM 742-BL gives an accurate, zero adjusted indication of a 4-20mA current. Calibration is by two multi-turn potentiometers which allow sensitive adjustment of the instrument over a very wide range. Decimal points are jumper link selectable. A low drift bandgap reference circuit ensures accurate readings over a wide temperature range. LED backlighting ensures excellent readability under low light conditions. Connection is via screw terminals. The module's low cost means it will suit high and low volume applications. This module is supplied with a plastic mounting bezel. A waterproof seal to IP67 / NEMA 4X is achievable, using the optional BEZ 700-IP metal bezel.

FEATURES

- 12.7mm (0.5") Digit Height
- 4-20mA Loop Powered Indication
- Low Volt Drop
- Programmable Decimal Points
- LED Backlighting (30mA @ 5V typ.)
- Bandgap Reference
- Wide Adjustment Range
- Auto-polarity on Display
- IP67 / NEMA 4X Protection via BEZ 700-IP



ORDERING INFORMATION

Standard Meter
IP67 / NEMA 4X Bezel

Stock Number
DPM 742-BL
BEZ 700-IP

ELECTRICAL SPECIFICATIONS

Specification	Min.	Typ.	Max.	Unit
Accuracy (overall error) *	0.05		0.1	% (± 1 count)
Linearity			± 1	count
Sample rate		2.5		samples/sec
Operating temperature range	0		50	$^{\circ}\text{C}$
Temperature stability		200		ppm/ $^{\circ}\text{C}$
Loop Volt Drop	5	5.6		V
Supply current	4		20	mA
Backlight supply voltage	4.75	5.0	**	V d.c.
Backlight supply current @ 5V d.c.		30	50***	mA
Full scale reading (@20mA)	0		1999	Count
Offset adjustment range	-1900		+1900	Count

* To ensure maximum accuracy, re-calibrate periodically.

** An external series resistor is required above 5V, see Applications.

*** This specification linearly derates to 30mA @ 50 $^{\circ}\text{C}$.

DPM 742-BL

4-20mA Loop Powered Indicator with Backlighting

DIMENSIONS

All dimensions in mm (inches)

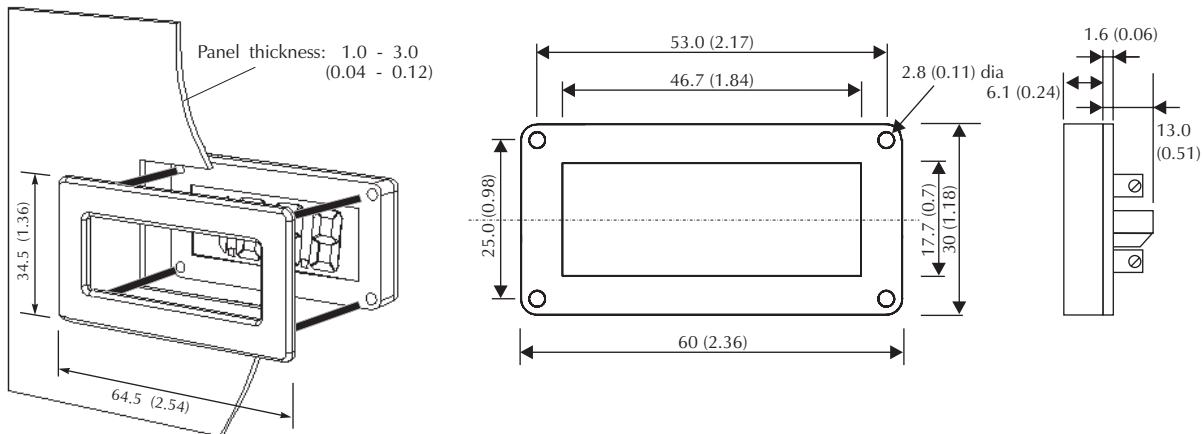

PANEL FITTING

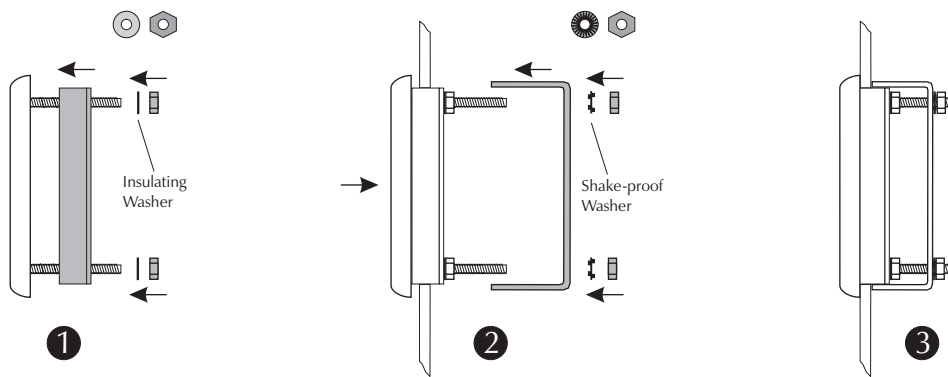

FUNCTIONAL BLOCK DIAGRAM

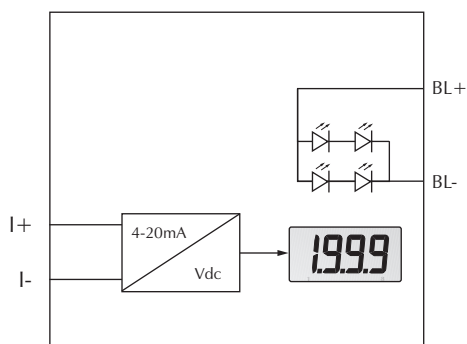

CONNECTIONS (rear view)

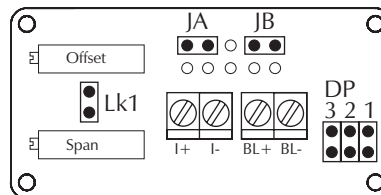

CIRCUIT DIAGRAM

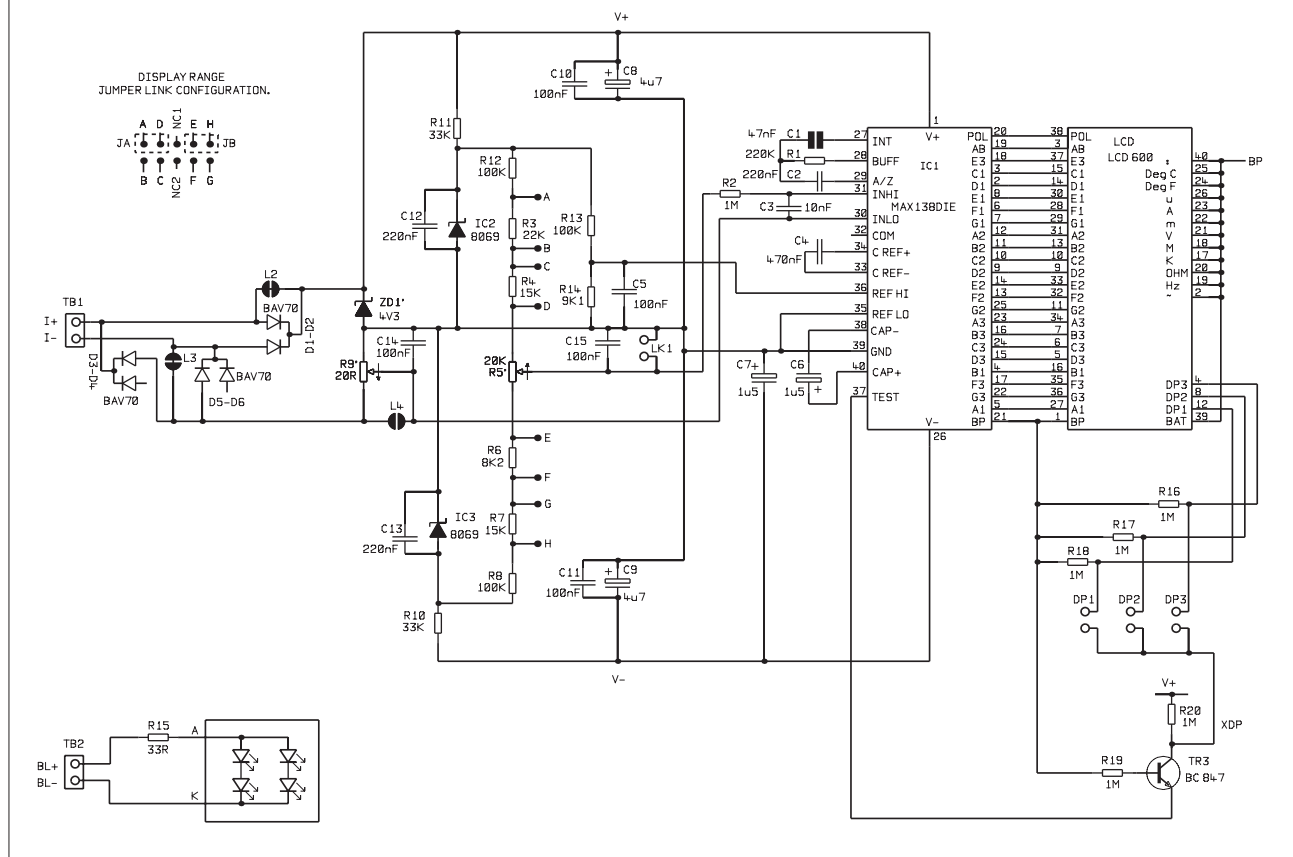

SCREW TERMINAL FUNCTIONS

- I+ Positive current input.
- I- Negative current input.
- BL+ Positive power supply connection to the LED backlighting.
- BL- Negative power supply connection to the LED backlighting.

CALIBRATION

The meter is supplied calibrated to read 000 for 4mA loop current and 1000 for 20mA.

To re-calibrate, place the Jumper Link across LK1. This disables the Offset adjustment to enable Span adjustment to be made first. After Span adjustment is complete, the Jumper Link is removed and the Offset adjustment is made. The Jumper Link is then used to display one of the decimal points if necessary.

Example to re-calibrate: Meter to read -40.0 at 4mA and 150.0 at 20mA.

1. Calculate the Span by subtracting the desired reading at 4mA from the desired reading at 20mA: $1500 - (-400) = 1900$
2. Place Jumper Link Lk1 with the link header normally used to select the desired Decimal Point. Link Lk1 is located to the left of the screw terminals.
3. Apply 16mA between the + and - screw terminals.
4. Adjust the Span potentiometer so the DPM 742-BL indicates 1900.
5. Remove Jumper Link Lk1 and place it back on the desired Decimal Point (DP1 in this case).
6. Apply 4mA between the - and + screw terminals.
7. Adjust the Offset potentiometer so the DPM 742-BL indicates the desired reading at 4mA: -40.0
8. Adjust Span and Offset as necessary for optimum accuracy. First apply 20mA and adjust Span until the reading is 150.0. Then apply 4mA and adjust Offset until the reading is -40.0. Repeat step 8 until correct readings are obtained at 4mA and at 20mA.

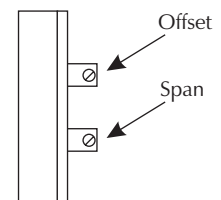

JUMPER LINKS

- DP1 Displays decimal point DP1 (199.9).
- DP2 Displays decimal point DP2 (19.99).
- DP3 Displays decimal point DP3 (1.999).
- Lk1 Used during calibration (see above).

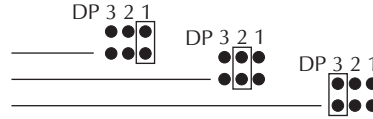

APPLICATIONS

The DPM 750-BL is powered from the 4-20mA signal loop and needs no other power supply. The LED backlighting requires a separate d.c. power supply. Ensure correct polarity when connecting.

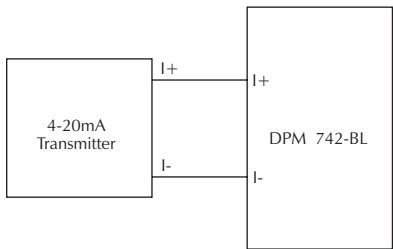

Measuring a 4-20mA loop current.

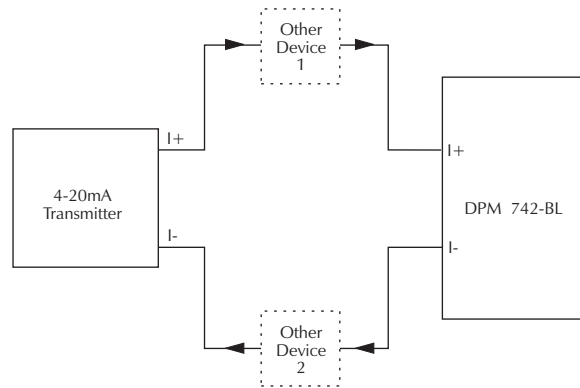

Measuring a 4-20mA loop current with other devices in the loop.

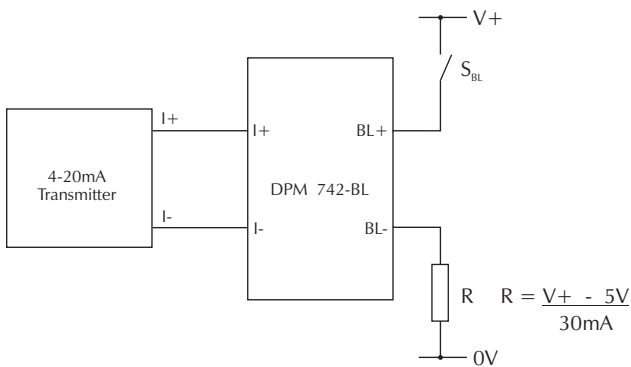

Measuring a 4-20mA loop current with LED Backlighting switched on.

Note:

If the backlighting supply voltage (V+ - 0V) = 5V, then no resistor R is required, and connect BL- to 0V.