

This meter will give a direct reading in °C from a K type (chromel-alumel) thermocouple sensor. The circuit uses a converter/amplifier which has Cold Junction Compensation. Calibration is by two 20-turn cermet potentiometers which allow sensitive adjustment of the instrument. The meter can also operate without a thermocouple to read room temperature. The meter is housed in a robust carrier, which can be bolted in place or panel mounted using the low profile bezel, window and clips provided. The meter can also be backlit for use in poor visibility.

- 🔊 19mm (0.75") Digit Height
- 🔊 Cold Junction Compensation
- 🔊 Simple Connection
- 🔊 LED Backlighting



CALIBRATION

1. Place thermocouple at 0°C and adjust OFFSET to read 000.
2. Place thermocouple at known reference temperature, eg. 100°C and adjust CAL to read 100.
3. Repeat steps 1 and 2 until there are no more adjustments of CAL and OFFSET required to give desired readings.

In room temperature application adjust CAL to give the same reading as a known temperature reference.

Standard Meter				Stock Number
				DTM 995
Specification	Min.	Typ.	Max.	Unit
Accuracy (overall error) ***		1		% (±1 count)
Thermocouple measurement range	-50		+600	°C
	-58		+1112	°F
Power supply voltage (V+ to V-)**	7.5	9.0	24	V
Operating temperature range *	0		50	°C
Temperature stability			0.05	°C/°C
Supply current		3.5		mA
Supply current with backlighting		55		mA

* Module temperature

** 5V supply option available - Contact Sales for details

*** To ensure maximum accuracy, re-calibrate periodically

CONNECTOR SOURCING GUIDE

METHOD Screw Terminals - No Connector Required

SAFETY

The user must ensure that the incorporation of the DPM into the user's equipment conforms to the relevant sections of BS EN 61010 (Safety Requirements for Electrical Equipment for Measuring, Control and Laboratory Use).

DIMENSIONS All dimensions in mm (inches)

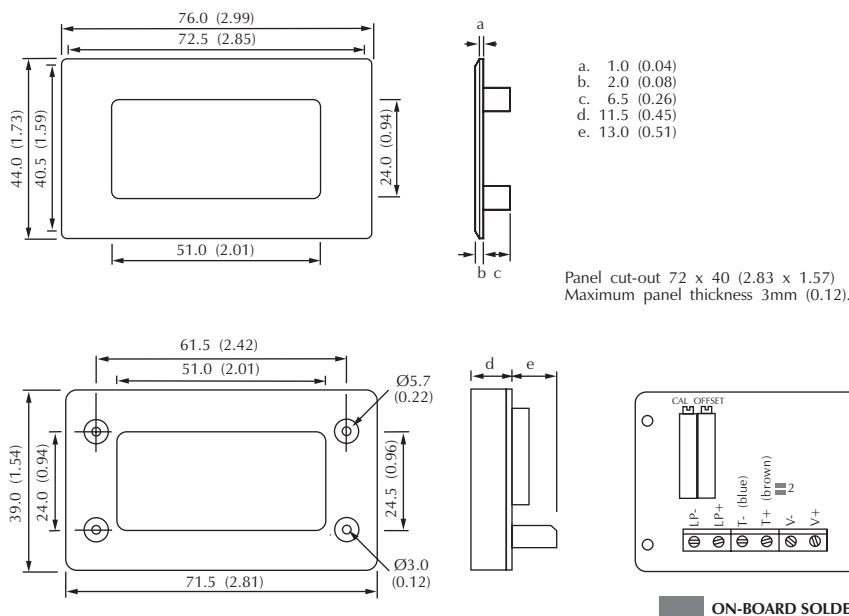

PIN FUNCTIONS

1. V+ Positive power supply connection.
2. V- Negative power supply connection.
3. T+ Connection for positive (Ni-CR) part of thermocouple Green (Brown).
4. T- Connection for negative (Ni-AL) part of thermocouple White (Blue).
5. LP+ Positive power supply for backlighting.
6. LP- Negative power supply for backlighting.

Note- When connecting thermocouples, ensure that the wires are carefully cleaned and are connected directly to the module and not to some intermediate connector other than a proper K type thermocouple extension cable.

ROOM TEMPERATURE METER

To use the internal temperature sensor, simply apply a short circuit to T+/T- (LK2).

VARIOUS OPERATING MODES

ON-BOARD LINKS: In order to quickly and easily change operating modes for different applications, the meter has several on-board links. They are designed to be easily opened (cut) or shorted (soldered). Ensure thermocouple probes are isolated.



BACKLIGHTING

There are two ways to power the LED backlight. Either use a 5V ($\pm 10\%$) supply on LP+/LP- or use the internal meter 5V supply. If the internal supply is used, the power supply voltage is limited to 7.5 - 15V D.C.

THERMOCOUPLE MEASUREMENT

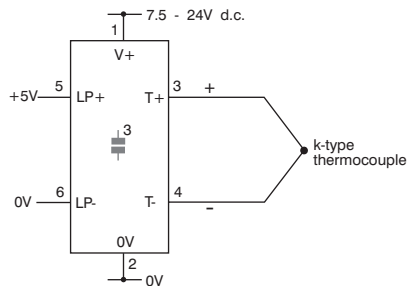

With external backlight supply.

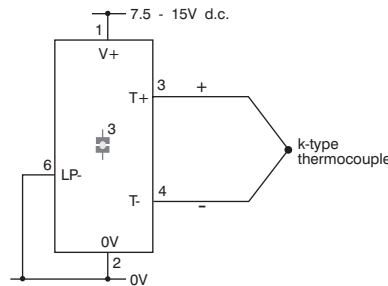

With internal (continuous) backlight supply. Short link 3.

ROOM TEMPERATURE MEASUREMENT

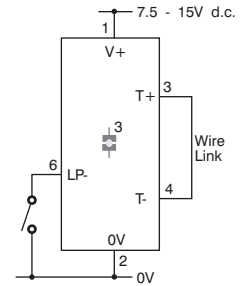

With internal (switched) backlight supply. Short link 3.

Note: For thermocouple colour coding, refer to FAQ on our website.

PANEL FITTING

