

### PRODUCT DESCRIPTION

The DPM 3AS-BL features a 200mV d.c. measurement range with auto-zero and auto-polarity. Decimal points are user selectable. The DPM 3AS-BL features a negative rail generator which enables the meter to measure a signal referenced to its own power supply GND. LED backlighting ensures excellent readability under low light conditions. The design of the panel meter's housing allows the module to be easily snapped into a panel. The module's low cost means it will suit high and low volume applications. The DPM 3AS-BL is intended to replace the DPM 3, DPM 3S, DPM 3-BL and DPM 3S-BL in many applications, usually requiring only minor circuit modifications.

### FEATURES

- 11mm (0.43") Digit Height
- 200mV d.c. Full Scale Reading
- 3.0 to 7.5V or 6.0 to 15.0V Operation
- Auto-zero and Auto-polarity
- Programmable Decimal Points
- LED Backlighting



### TYPICAL APPLICATIONS

- Precision Instrumentation Systems
- Power Supply Monitoring
- Hand held instruments
- Panel-Mount Indication
- Low Power Voltage Measurement

### ORDERING INFORMATION

Standard Meter

Stock Number  
**DPM 3AS-BL**

### ELECTRICAL SPECIFICATIONS

Specification	Min.	Typ.	Max.	Unit	
Accuracy (overall error) *		0.1		% (-1 count)	
Linearity			-1	count	
Sample rate		2.5		samples/sec	
Operating temperature range	0		50	°C	
Temperature stability		250		ppm/°C	
Meter supply voltage	V+ to GND configuration	3.0	5.0	7.5	V d.c.
	V+ to V- configuration	6.0	9.0	15.0**	V d.c.
Meter supply current	V+ to GND configuration		350		μA
	V+ to V- configuration		175		μA
Backlight supply voltage	4.75	5.0	***	V d.c.	
Backlight supply current @ 5V d.c.		40	60	mA	
Input leakage current (Vin = 0V)		1	10	pA	

\* To ensure maximum accuracy, re-calibrate periodically.

\*\* Operation of the meter beyond the maximum supply voltage rating may cause permanent damage to the meter.

\*\*\* An external series resistor is required above 5V, see Applications.

Unless otherwise noted, specifications apply at  $T_A = 25^\circ\text{C}$ ,  $V_{\text{supply}} = 5\text{V d.c.}$  ( $f_{\text{clock}} = 48\text{kHz}$ ) and are tested with the module configured for fully floating input mode.

### SAFETY

To comply with the Low Voltage Directive (LVD 93/68/EEC), input voltages to the module's pins must not exceed 60Vdc. The user must ensure that the incorporation of the panel meter into the user's equipment conforms to the relevant sections of BS EN 61010 (Safety Requirements for Electrical Equipment for Measuring, Control and Laboratory Use).

### DIMENSIONS

All dimensions in mm (inches)

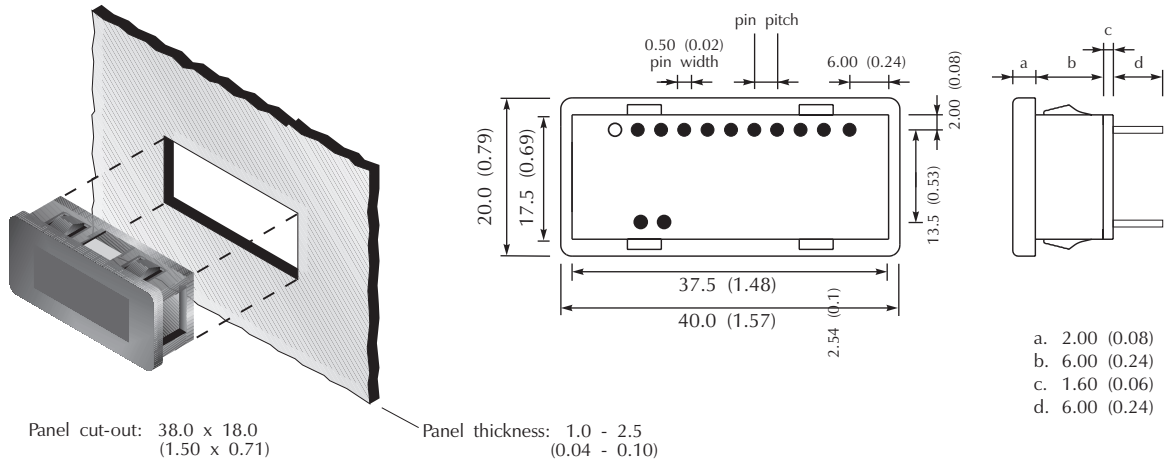

### PANEL FITTING

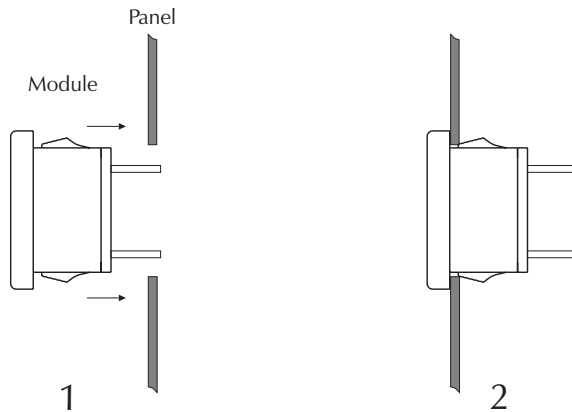

### FUNCTIONAL BLOCK DIAGRAM

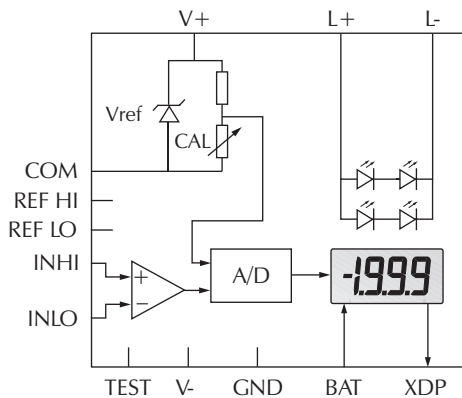

### PIN CONFIGURATION (rear view)

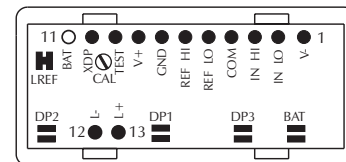

### CIRCUIT DIAGRAM

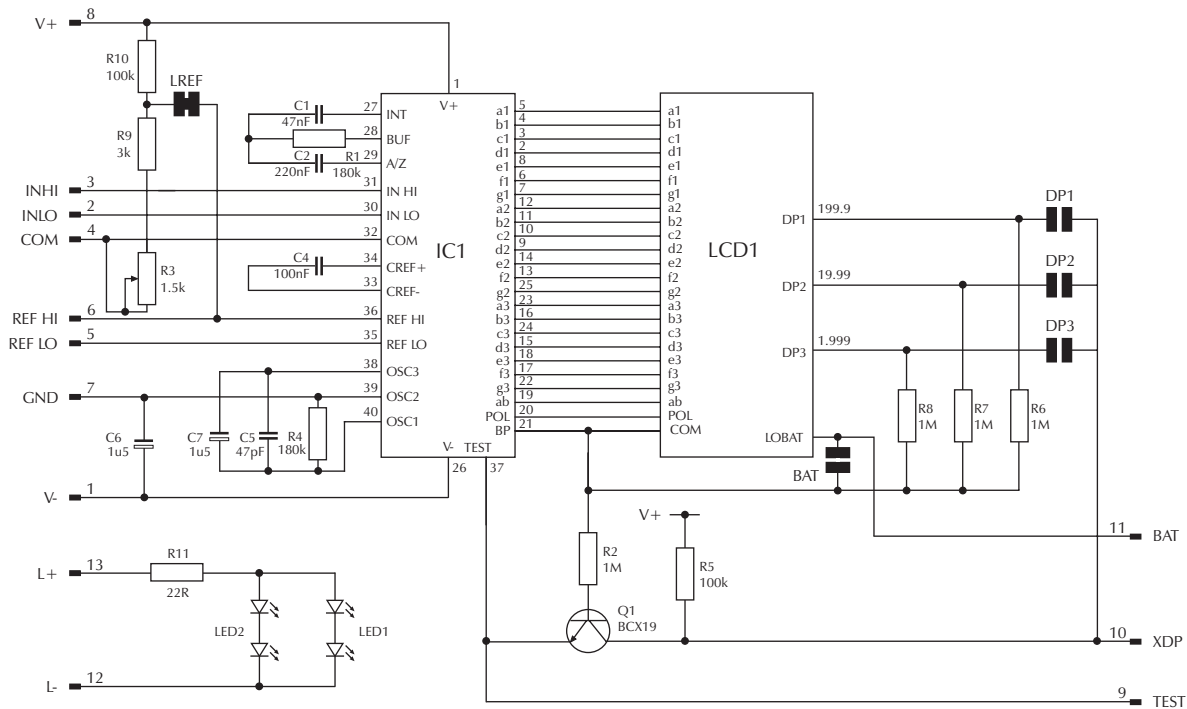

### PIN FUNCTIONS

1. V- Negative power supply to the meter (6.0 to 15.0V meter power supply applications only).
2. INLO Negative measuring input.
3. INHI Positive measuring input.
4. COM Ground for the analogue section of the A/D converter. It is actively held at 3.05V (nom.) below V+ and must not be allowed to sink excessive current (> 100µA) by, for instance, connecting to a higher voltage.
5. REFLO Negative input for reference voltage.
6. REFHI Positive input for reference voltage.
7. GND 0V power supply to the meter (3.0 to 7.5V meter power supply applications only).
8. V+ Positive power supply to the meter.
9. TEST Connect to V+ to test the LCD. Do not connect to V+ for more than a few seconds as this may damage the LCD. TEST is held actively at 5V (nom.) below V+ and is the ground for the digital section of the meter. It can be used to power external logic up to a maximum of 1mA.
10. XDP Inversion of LCD drive voltage.
11. BAT Low Battery annunciator drive pin. See application on the right. This pin is not fitted as standard.
12. L- Negative power supply to LED backlighting.
13. L+ Positive power supply to LED backlighting. The backlighting is internally configured for 5V operation. If a higher voltage is used, then add a series current limiting resistor Rs. See Applications for calculations of Rs.

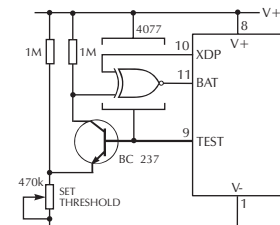

Check Link BAT is OPEN.

#### Note:

A negative supply is generated internally and mirrors the positive supply. For example: if V+ is +5V then the internally generated V- is -5V. When measuring with the input referenced to the same supply rail as that of the panel meter, then the limitations on the input range are (V- + 1.5V) to (V+ - 1.5V).

#### Solder Links:

- LREF Normally Closed. Enables the internal voltage reference circuit. Cut this link when using an external voltage reference.
- BAT Normally Open. Disables the Low Battery warning annunciator. Cut this link and add a low battery detection circuit to enable the Low Battery warning annunciator via Pin 11 (BAT).
- DP1 Normally Open. Close this solder link to enable decimal point DP1.
- DP2 Normally Open. Close this solder link to enable decimal point DP2.
- DP3 Normally Open. Close this solder link to enable decimal point DP3.

### SCALING

Two external resistors  $R_a$  and  $R_b$  may be used to alter the full scale reading (FSR) of the meter - see table. The meter will have to be re-calibrated by adjusting the calibration potentiometer on the rear of the module.

	FSR	$R_a$	$R_b$
Voltage ( $V_{in}$ )	2V	910k	100k
	20V	1M	10k
	200V	1M	1k
	2000V*	1M	100R
Current ( $I_{in}$ )	200 $\mu$ A	0R	1k
	2mA	0R	100R
	20mA	0R	10R
	200mA	0R	1R

\*Ensure that  $R_a$  is rated for high voltage use.

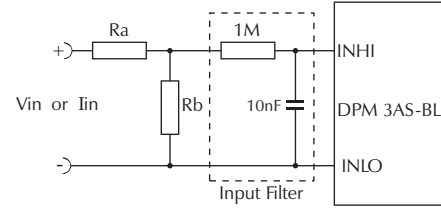

### APPLICATIONS

Do not connect more than one meter to the same power supply if the meters cannot use the same signal ground. Taking any input beyond the power supply rails will damage the meter.

#### 5V supply operation (3.0 to 7.5V Meter Power Supply)

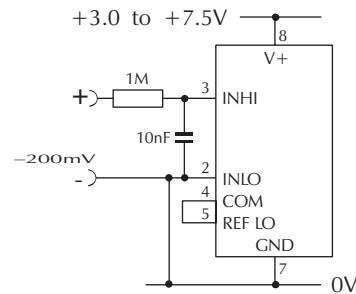

Measuring a single ended input voltage referenced to supply, i.e. the input voltage and the meter's power supply share the same 0V rail. Ensure solder link LREF is closed.

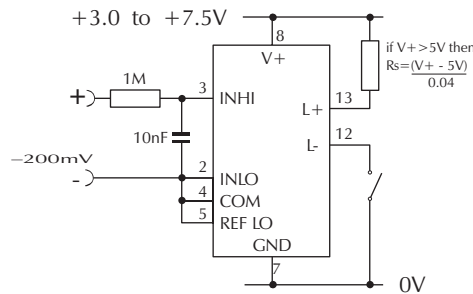

Measuring an input voltage referenced to a floating supply, i.e. the input voltage and the meter's power supply are isolated from each other. Ensure solder link LREF is closed.

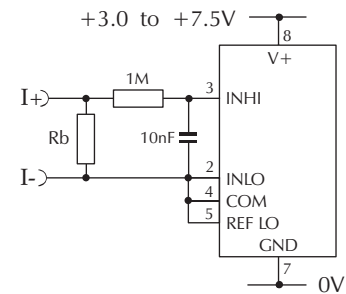

Measuring a current from a circuit which is floating with respect to the DPM's supply, i.e. the current and the meter's power supply are isolated from each other. Ensure solder link LREF is closed.

#### 9V supply operation (6.0 to 15.0V Meter Power Supply)

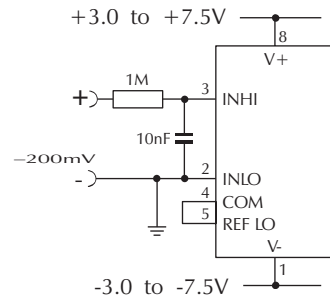

Measuring a single ended input voltage referenced to supply, i.e. the input voltage and the meter's power supply share the same 0V rail. Ensure solder link LREF is closed.

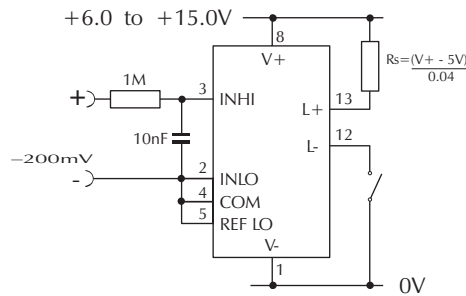

Measuring an input voltage referenced to a floating supply, i.e. the input voltage and the meter's power supply are isolated from each other. Ensure solder link LREF is closed.

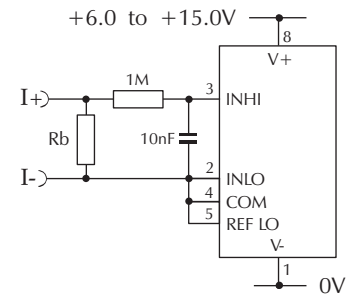

Measuring a current from a circuit which is floating with respect to the DPM's supply, i.e. the current and the meter's power supply are isolated from each other. Ensure solder link LREF is closed.