

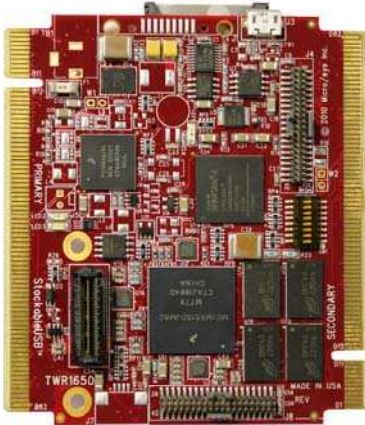

i.MX515 ARM Cortex-A8 Tower Computer Module TWR1650



Features

- ✓ ARM Cortex-A8 processor, 800MHz
- ✓ 512MB SDRAM, 1GB Flash
- ✓ Four (4) USB ports
- ✓ 10/100BASE-T Ethernet
- ✓ Controller Area Network (CAN) port
- ✓ Five (5) serial ports
- ✓ One (1) SD/MMC card slot
- ✓ 16 bits of digital I/O



The TWR1650 is an i.MX515 evaluation module boasting a subset of features common to an industrial-grade single board computer. Featuring an 800MHz ARM Cortex-A8 CPU, the TWR1650 delivers the performance needed to enable multimedia rich applications in rugged, harsh environments. Although rich in embedded I/O features, the TWR1650 consumes minimal power, simulating the demanding environmental conditions in which OEMs must operate. OEM versions of the SBC are available to ease transition from development to production.

On-board peripherals include 10/100BASE-T Ethernet, USB On-the-Go, a real-time clock,

watchdog timer, 24-bit TFT, flat panel display output, keypad, two (2) PWM outputs, a bootable SD/MMC card slot, 1-Wire interface, one (1) serial port, CAN, and (16) lines of discrete I/O. More serial ports, CAN, and another SD/MMC interface are accessible through the Tower's card-edge connectors. For additional expansion, the TWR1650 comes equipped with the rugged StackableUSB interface for well-defined board-to-board communication via USB, I²C, and SPI.

For the complete off-the-shelf, OEM single board computer version, see the SBC1651 and the SBC1652.

Software Support

Linux
Windows CE
VxWorks
Android
C, compilers

Compatible Hardware

StackableUSB Client Devices
PC Hosts
PSxxx, Power Supplies
Secure Digital Devices
RS232/RS485 Devices
CAN Devices
Ethernet Networks

Mounting/Packaging

Standoffs, STDOFFUSB

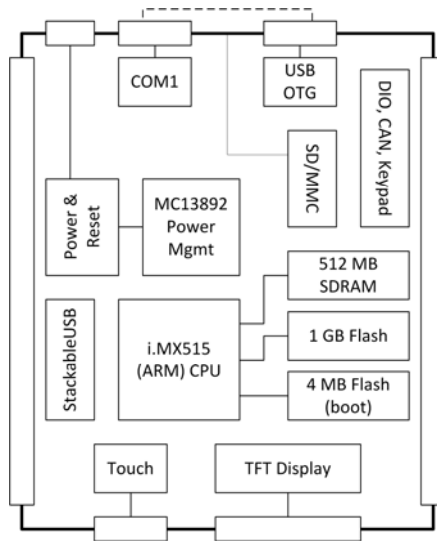

Technical Details:

At the heart of the TWR1650 is the Freescale i.MX515 multimedia applications processor, a System on Chip (SOC) offering high-performance processing optimized for the lowest power consumption. The core of i.MX515 is an 800MHz ARM Cortex-A8 CPU. The CPU is augmented by a floating-point coprocessor, ARM's NEON SIMD media accelerator, and OpenGL ES 2.0 and OpenVG 1.1 hardware accelerators for fast, power-efficient graphics operations.

The i.MX515 SOC integrates many peripherals, including an interrupt controller, watchdog timer, SDRAM and flash memory controllers, three (3) High-Speed USB ports, one (1) Full-Speed On-The-Go USB port, one (1) 10/100 Ethernet MAC, three (3) 16C550 UARTs, 1-Wire interface, 24-bit flat panel display output, an 8-row x 6-column keypad controller, and PWM outputs.

In addition to the peripherals built into the i.MX515, the TWR1650 adds two (2) more 16C550 UARTs, a Controller Area Network (CAN) controller, and 16 bits of 82C55A-compatible programmable parallel I/O.

The TWR1650 offers three boot options: A dedicated 4MB SPI NOR flash memory, a partition of the NAND flash, and a bootable SD/MMC card slot.

The TWR1650 memory subsystem provides 512MB of DDR2 SDRAM for application data. The 4MB SPI NOR flash memory holds the bootloader and operating system. 1GB NAND flash is available for operating system and non-volatile user storage.

If a larger program or data storage space is required, or if removability is needed, a second SD/MMC interface can be accessed via the Tower's card-edge connector.

Five (5) 16C550-compatible RS232 serial ports allow communication with low-speed devices. Four of the ports are accessed via the Tower's card-edge connector; the fifth is on-board and software-configurable for half-duplex RS485 communication.

The TWR1650 can be powered from an external 5 VDC source or a battery. If external power is supplied while a battery is

plugged in, the battery will be recharged. Advanced power management is enabled by the new Freescale MC13892.

The TWR1650 becomes a powerful front-end processor for control applications with the standard StackableUSB expansion. This popular I/O channel accommodates multiple stacked I/O boards without use of a hub.

For true 32-bit application development, the TWR1650 supports 32-bit operating systems such as Linux and Windows CE. Both have full tool suites available, including compilers and debuggers.

Specifications:

Mechanical:

- ❑ Freescale Tower form factor
- ❑ 3.543" x 3.197"
- ❑ Installed Secure Digital (SD) card extends past edge of board

Power Requirements:

- ❑ +5v $\pm 5\%$ at TBD A typical, TBD A max
- ❑ Battery input voltage up to 4.8V

Power Connector	
Pin	Signal
1	+5V
2	Battery Input
3	GND

Environmental:

- ❑ Operating range 0° to +70°C
- ❑ -40° to +85°C storage
- ❑ 5%-95% relative humidity, non-condensing

Processor Core Section:

- ❑ Freescale i.MX515 multimedia applications processor
- ❑ 800 MHz ARM Cortex-A8 CPU core
- ❑ Hardware graphics accelerators (video, OpenGL ES 2.0 and OpenVG 1.1)

On-board Memory:

- ❑ 512MB DDR2 Synchronous DRAM
- ❑ 4MB SPI NOR flash
- ❑ 1GB NAND flash

Memory Expansion:

- ❑ One (1) SD/MMC card slot
- ❑ One (1) SD/MMC interface on Tower card-edge connector

Watchdog Timer:

- ❑ Program must refresh watchdog timer periodically, or system will be reset
- ❑ Enabled through software

COM1-COM5 Serial Ports:

- ❑ Five (5) asynchronous serial ports
- ❑ 16C550-compatible
- ❑ RTS and CTS modem controls (all except COM3)
- ❑ RS232 on all channels
- ❑ COM1 RS485 half-duplex
- ❑ COM2 – COM5 on Tower card-edge connector

10/100BASE-T Ethernet:

- ❑ One (1) 10/100BASE-T Ethernet port on Tower card-edge connector

USB:

- ❑ One (1) Full-Speed On-The-Go USB 2.0 port, providing device and limited Host functions, Micro-AB connector
- ❑ Three (3) High-Speed USB 2.0 Host ports, StackableUSB connector
- ❑ Transfers at High-Speed 480Mbit/sec, Full-Speed 12Mbit/sec, or 1.5Mbit/sec

Controller Area Network:

- ❑ CAN version 2.0B, 1Mbit/sec on-board and on Tower card-edge connector
- ❑ Standard and extended data and remote frames
- ❑ Two (2) receive buffers and three (3) transmit buffers with prioritized message storage

Real Time Clock:

- ❑ RTC with rechargeable on-board battery

Digital I/O:

- ❑ 82C55-compatible digital I/O:
 - 16 TTL bi-directional signals
 - Direction programmable in two (2) groups of eight bits
 - 470-ohm current-limiting resistors on all lines
- ❑ I²C (on StackableUSB connector)
- ❑ SPI (on StackableUSB connector)
- ❑ 1-Wire interface
- ❑ Two (2) PWM outputs
- ❑ 8-row x 6-column keypad

Video I/O:

- ❑ 24-bit TFT flat panel display output

External Connections:

- ❑ Tower card-edge connectors for PWM, 1-Wire, SPI, I²C, COM2-COM5, CAN, Ethernet, SD/MMC, TFT display out
- ❑ 40-pin header for digital I/O, CAN, and keypad interface
- ❑ 40-pin header for TFT display out
- ❑ One (1) SD/MMC card slot
- ❑ One (1) USB Micro-AB USB connector
- ❑ One (1) DB-9 connector for COM1 RS232 and RS485
- ❑ 2-pin locking header for reset
- ❑ 2.1mm barrel power input

StackableUSB trademark Micro/sys, Inc.

VxWorks trademark Wind River

Android trademark Google, Inc.

Ordering Information:

Tower Modules:

- TWR1650-Linux* i.MX515 ARM Cortex-A8 Computer Module for the Tower System, Linux-ready
- TWR1650-WinCE* i.MX515 ARM Cortex-A8 Computer Module for the Tower System, WinCE-ready

Related Tower System Offerings:

- CRR-TOWER Carrier Board for two (2) – four (4) top-mounting ¼-size 104 Form Factor boards for the Tower System
- HUB-TOWER Hub Carrier Board for two (2) – four (4) top-mounting ¼-size 104 Form Factor boards for the Tower System

Related OEM Offerings:

- SBC1651[†] i.MX515 ARM Cortex-A8 CPU, 800MHz, 512MB SDRAM, 4MB NOR Flash, dual Ethernet, 104 Form Factor
- SBC1651-ET[†] i.MX515 ARM Cortex-A8 CPU, 600MHz, 512MB SDRAM, 4MB NOR Flash, dual Ethernet, 104 Form Factor, -40°C to +85°C operating temperature
- SBC1652[†] i.MX515 ARM Cortex-A8 CPU, 800MHz, 512MB SDRAM, 4MB NOR Flash, 2.5"x3.5" handheld
- SBC1652-ET[†] i.MX515 ARM Cortex-A8 CPU, 600MHz, 512MB SDRAM, 4MB NOR Flash, 2.5"x3.5" handheld, -40°C to +85°C operating temperature

**Ships with a 4G Micro SD/MMC Card.*

†Turn-key development kits available.