



High Accuracy Analog and Digital I/O for PC/104 MPC560



Features

- ✓ 32 channels of 16-bit analog input
- ✓ Fault protection on analog/digital
- ✓ Ultra-low noise design
- ✓ DSP and noise analysis software
- ✓ Low-pass filtering
- ✓ 14-bit, 4-channel DAC
- ✓ Digital I/O, Counter/Timer
- ✓ 5V only operation from PC/104
- ✓ Extended temperature range available

The MPC560 provides up to 32 single-ended 16-bit analog inputs that are fault protected to $\pm 40V$. The analog input section offers individual channel selection of single-ended or differential modes in any combination. The MPC560 also features basic and autoscan modes. Basic mode directly controls all modes, gains, channel selection, and filters. With autoscan mode, a user can preset individual channel attributes – channel on/off, mode, gain, and lowpass filter in on-board RAM.

In autoscan mode, a pacer clock and the DMA controller automatically move samples to system memory. The analog input includes a low-drift reference, noise-protected by a faraday shield.

The optional 14-bit analog outputs have full-scale output of $\pm 10.1V$. The digital-to-analog converter is noise-protected by a faraday shield. Each output has a 1-pole lowpass filter.

Twelve digital I/O lines can be individually set for input or output, with fault protection against power sequencing and static discharge.

All analog power supplies are generated from the 5V input. The on-board analog supplies include input and output filtering, and post-regulation of the initial converters, providing low-noise and stable power.

Software Support

*Example code for all functions
C-code/Mathcad™ for advanced algorithms*

Compatible Hardware

*Any Micro/sys CPU with
PC/104 expansion connector*

Mounting/Packaging

PC/104 standard

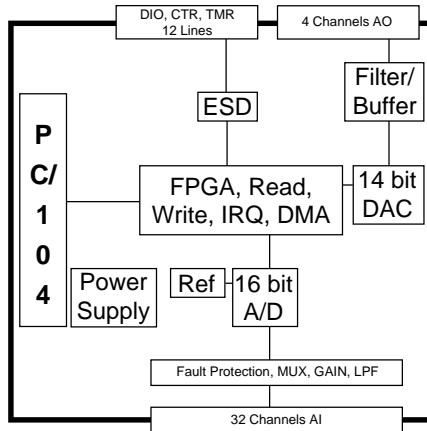

Specifications:

Mechanical:

- PC/104 standard
- 3.55" (plus I/O region) x 3.775"

Power Requirements:

- +5V \pm 5% at 500mA

Environmental:

- 0° - +70°C operating
- 40° - +85°C operating, -ET version
- 5%-95% relative humidity, non-condensing

PC/104 Interface:

- 16-bit transfers
- IRQ 3, 4, 5, 6, 7, 9, 10, 11, 12, 14, 15 supported
- DMA 5, 6, 7 supported

Digital I/O:

- 12 Multi-function TTL-level bit selectable I/O at 8mA sink/source
- Ext-trigger, Ext-pacer clock, User I/O
- Any/all inputs can generate an IRQ
- Read-back function on outputs

Analog Inputs:

- 16-bit, 32-channels individually selected for single/differential
- ADC conversion time of 5usec
- 3dB typical full-power response of input circuitry:
 - 20Vpp @35kHz, 5Vpp @ 100kHz
- Each channel can be set by software for the following attributes:
 - on/off, single/differential, input range of \pm 5.05V or \pm 10.1V,
 - Lowpass filter(1kHz or 100kHz)
- Default Basic Mode from reset allows readings of individual channels from software directly with EOC being Polled/IRQ.
- Auto-scan Mode waits for an ext-trigger or software to start the pacer-clock to systematically run through each channel with its preset values and store the data into CPU DRAM with DMA

Analog Outputs:

- 14-bit, 4-channels
- 10usec DAC settling time
- Each channel has a 1-pole reconstruction filter and output buffer
- \pm 10.1V output

Counter/Timer:

- 1Mhz 16-bit timer for pacer-clock

External Connections:

- 50-pin header for analog input
- 16-pin header for digital/counter/timer I/O
- 10-pin header for analog output

Ordering Information:

MPC560	16-bit, 16-channel analog input, digital I/O
MPC560-ET	16-bit, 16-channel analog input, digital I/O, extended temperature operation
560OPT11	16-bit, 32-channel analog input, digital I/O
560OPT12	14-bit, 4-channel analog output

Add -ET to option for extended temp operation

Related Products:

CA5049	50-pin to 50-pin ribbon cable
CA4002	16-pin to 16-pin ribbon cable
CA5052	10-pin to 10-pin ribbon cable
TB5001	Breakout Board, 50-point terminal strip

Mathcad trademark MathSoft Engineering and Education, Inc.