



High Voltage, High Current, Opto Isolated I/O for PC/104 MPC116



Features

- ✓ 32 Lines of industrial I/O
- ✓ Open emitter outputs source up to 350mA, 60VDC max
- ✓ Inputs sink current from 24V (nominal) inputs
- ✓ Series resistors on inputs allow other voltages
- ✓ Eight outputs optionally opto isolated
- ✓ Eight inputs optionally opto isolated
- ✓ PC/104 format

The MPC116 provides 32 lines of digital I/O for use in PC/104 applications. It implements 16 digital inputs and 16 digital outputs that can be connected to non-TTL devices such as lamps and relays. Output transistors, rated at 60V max, source current from a user-supplied voltage. Inputs are turned on by sourcing current into them from an external source from 12VDC to 60VDC, set by user-changable series resistors.

Two optical isolation options are available. Eight of the MPC116 output lines can be optically isolated with on-board solid state-relays, and eight of the inputs can be optically isolated on-board.

Software Support



Compatible Hardware

*Any Micro/sys CPU with
PC/104 expansion connector
[See Section 1]
Digital racks, PB8H, PB16H,
PB24
Terminal Boards, TB5001,
TB5002
[Items above in section 4]
Custom interfacing*

Mounting/Packaging

PC/104 standard

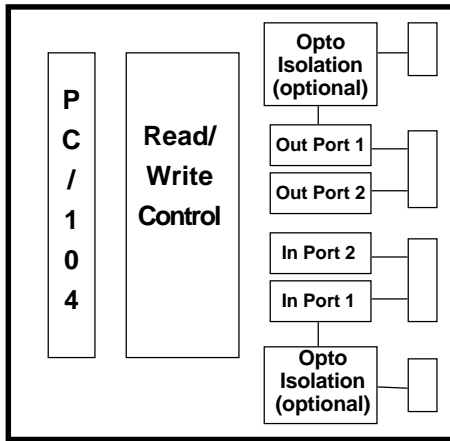

Specifications:

Mechanical:

- PC/104 standard
- 3.55" (plus I/O region) x 3.775" x .6"

Power Requirements:

- +5V \pm 5% at TBD max
- User-supplied output voltage source, 6V to 50VDC

Environmental:

- 0° - +70°C operating
- 25° - +85°C storage
- 5%-95% relative humidity, non-condensing

PC/104 Interface:

- 8-bit PC/104 module
- 4 sequential I/O ports, jumper settable

Digital Output Lines:

- Two ports, 8-bits each
- Read back capability
- 4 LEDs display status of 4 output lines
- "On" output sources current to connector pin from user-supplied voltage
- Diode clamps to ground and to user-supplied voltage for inductive loads

- 350mA output current, max.
- Must derate to 50mA per output if all 8 outputs in same port are "on" simultaneously
- Vce saturation 1.8V at 350mA

Digital Input Lines:

- Two ports, 8-bits each
- Series resistor on each input pin, 15K, user-changeable
- Clamping diodes to protect logic
- External voltage source must supply current into input pin to turn "on"

Isolated Output option:

- Opto isolates 8 outputs
- Power FET outputs from solid state relay
- 400VDC max load voltage
- 300mA max load current, source or sink
- On resistance, 3.8 ohms, max
- Max relay power dissipation per output 750mW

Isolated Input option:

- Opto isolates 8 inputs
- Two isolated pins per input line
- Series resistor in each input line, 2.2K, user-changeable
- Turn-on current 5mA min, 80mA max

External Connections:

- 16-pin header with 16 non-isolated input lines
- 16-pin header with 16 non-isolated output lines
- 16-pin header with optional 8 opto isolated input lines
- 16-pin header with optional 8 opto isolated output lines

Ordering Information:

MPC116	32-line industrial I/O card
116OPT1	8 channel isolated input
116OPT2	8 channel isolated output