



LCD/Touchscreen Interface Boards for StackableUSB™ USB3201, USB3202, USB3203



Features

- ✓ Easily programmed using Microchip's Graphics Library for PIC32
- ✓ Onboard 3.2" (320x240) LCD w/ Touchpad
- ✓ Operates as Client to USB ports
- ✓ Additional 4Mbit (512Kx*) Flash and 256K EEPROM memory
- ✓ -10° to +60°C operation with LCD; -40° to +85°C without LCD
- ✓ CPU & RGB LCD interfaces available



The USB3200 series provides OEMs with a small, simple, cost-effective graphical user interface for rugged embedded systems. The LCD/Touchscreen and interface board can operate as a standalone controller with user interface or it can stack directly onto any StackableUSB Host computer or microcontroller. The USB3200 series development kits come with sample software and full documentation.

Powered by a Microchip PIC32 and the Microchip Graphics Library, the USB3201 features an on-board 3.2" (320x260 pixel) touchscreen LCD, while the USB3202 and the USB3203 versions support different LCD interface protocols allowing users to attach their own favorite display.

The boards provide +3.3V controllable signal via a digital switch for LCD power, and a high voltage LED driver which functions as an LCD backlight switch and brightness controller.

Programming custom buttons, graphics, and fonts can be easily done and uploaded to one of the USB3200 series. Furthermore, the highly-modular nature of the Microchip Graphics Library also allows OEMs to define their own screen layouts, while allowing for easy redrawing options.

With the PIC32 Graphics Library and USB Client Stack, the USB3200 series is a plug-and-play USB 2.0 Client device to any USB Host. The module stacks onto any StackableUSB Host single board computer or microcontroller or can be connected to desktop PCs via a Mini-B USB connector.

Software/Driver Support

Windows XP, Vista
MPLAB IDE
MPLAB C32 C Compiler
USB Client stack & Graphics
Library example software

Compatible Hardware

StackableUSB Host single board
computers and microcontrollers
PC host desktops and laptops
I2C, SPI, UART
MPLAB ICE
MPLAB ICD3
LCDs up to 480x272 WQVGA
4-wire touchpads

Mounting/Packaging

Full-size 104™ Form Factor
Standoffs, STDOFFUSB

Board Schematic:

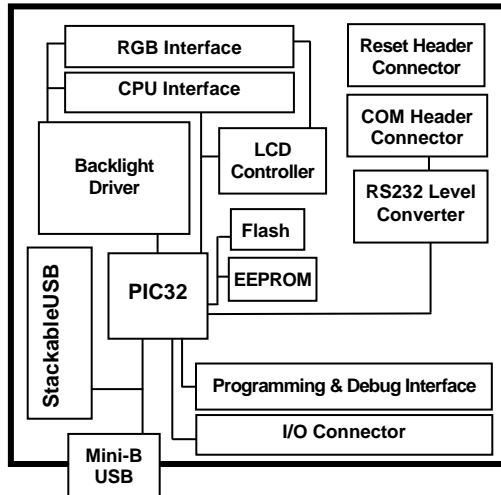

Figure 1: Front Side

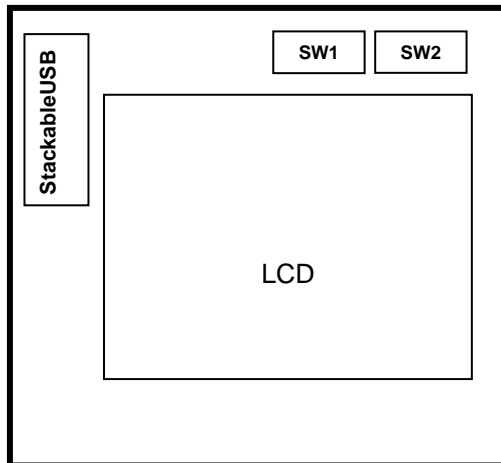

Figure 2: Backside

Specifications:

	USB3201	USB3202	USB3203
Summary	<ul style="list-style-type: none"> • LCD/Touchscreen Interface Board • On-board LCD 	<ul style="list-style-type: none"> • CPU LCD/Touchscreen Interface Board 	<ul style="list-style-type: none"> • RGB LCD/Touchscreen Interface Board
Mechanical	<ul style="list-style-type: none"> • Full-size 104 Form Factor™ mounting holes • 3.55" (plus I/O region) x 3.775" x 6" • Display size: 320 x 240 pixels, 3.2" 	<ul style="list-style-type: none"> • Full-size 104 Form Factor™ mounting holes • 3.55" (plus I/O region) x 3.775" x 6" 	<ul style="list-style-type: none"> • Full-size 104 Form Factor™ mounting holes • 3.55" (plus I/O region) x 3.775" x 6"
Power	<ul style="list-style-type: none"> • +5v ±5% • 448 mA 	<ul style="list-style-type: none"> • +5v ±5% • 409 mA + LCD 	<ul style="list-style-type: none"> • +5v ±5% • 409 mA + LCD
Environmental Requirements	<ul style="list-style-type: none"> • Operating temp: -10°to +60°C • Storage temp: -20°to +70°C • Relative humidity: 5%-95% non-condensing 	<ul style="list-style-type: none"> • Operating temp: -40°to +85°C • Storage temp: -55°to +150°C • Relative humidity: 5%-95% non-condensing 	<ul style="list-style-type: none"> • Operating temp: -30°to +85°C • Storage temp: -55°to +150°C • Relative humidity: 5%-95% non-condensing
LCD	<ul style="list-style-type: none"> • Truly <i>TFT2N0369-E</i> <ul style="list-style-type: none"> ○ 3.2" diagonal viewing area ○ 320x240 pixel ○ Touchpad 	<ul style="list-style-type: none"> • Not included <ul style="list-style-type: none"> ○ Up to 480x272 WQVGA ○ 4-wire touchpad ○ CPU Interface 	<ul style="list-style-type: none"> • Not included <ul style="list-style-type: none"> ○ Up to 480x272 WQVGA ○ 4-wire touchpad ○ RGB Interface
LCD Controller	<ul style="list-style-type: none"> • None 	<ul style="list-style-type: none"> • None 	<ul style="list-style-type: none"> • SSD1906
Processor	<ul style="list-style-type: none"> • MIPS32® M4K™ 32-bit core • 80MHz, 1.56 DMIPS/MHz • 5-stage pipeline, 32-bit ALU • 512KB flash, 32KB SRAM • Single-cycle multiply and high-performance divide unit • User and kernel modes to enable robust embedded system • Prefetch cache module to speed execution from flash 	<ul style="list-style-type: none"> • MIPS32® M4K™ 32-bit core • 80MHz, 1.56 DMIPS/MHz • 5-stage pipeline, 32-bit ALU • 512KB flash, 32KB SRAM • Single-cycle multiply and high-performance divide unit • User and kernel modes to enable robust embedded system • Prefetch cache module to speed execution from flash 	<ul style="list-style-type: none"> • MIPS32® M4K™ 32-bit core • 80MHz, 1.56 DMIPS/MHz • 5-stage pipeline, 32-bit ALU • 512KB flash, 32KB SRAM • Single-cycle multiply and high-performance divide unit • User and kernel modes to enable robust embedded system • Prefetch cache module to speed execution from flash
Peripheral Features	<ul style="list-style-type: none"> • 4-channel hardware DMA controller with automatic data size detection • USB 2.0 compliant full-speed controller • Dedicated DMA channel via USB • 4Mbit (512K x 8) flash memory • Hardware real time clock/calendar • Two (2) 16-bit timers/counters (two 16-bit pairs combine to create one 32-bit timer) • Two (2) external interrupt pins • Five (5) interrupt on change inputs • Eight (8) High-speed I/O pins capable of toggling at up to 80MHz • High-current sink/source (18 mA/18 mA) on all I/O pins • Configurable open-drain output on digital I/O pins • LCD backlight brightness control • 256K EEPROM • Digital MOSFET switches for LCD power and backlight control 	<ul style="list-style-type: none"> • 4-channel hardware DMA controller with automatic data size detection • USB 2.0 compliant full-speed controller • Dedicated DMA channel via USB • 4Mbit (512K x 8) flash memory • Hardware real time clock/calendar • Two (2) 16-bit timers/counters (two 16-bit pairs combine to create one 32-bit timer) • Two (2) external interrupt pins • Five (5) interrupt on change inputs • Eight (8) High-speed I/O pins capable of toggling at up to 80MHz • High-current sink/source (18 mA/18 mA) on all I/O pins • Configurable open-drain output on digital I/O pins • LCD backlight brightness control • 256K EEPROM • Digital MOSFET switches for LCD power and backlight control 	<ul style="list-style-type: none"> • 4-channel hardware DMA controller with automatic data size detection • USB 2.0 compliant full-speed controller • Dedicated DMA channel via USB • 4Mbit (512K x 8) flash memory • Hardware real time clock/calendar • Two (2) 16-bit timers/counters (two 16-bit pairs combine to create one 32-bit timer) • Two (2) external interrupt pins • Five (5) interrupt on change inputs • Eight (8) High-speed I/O pins capable of toggling at up to 80MHz • High-current sink/source (18 mA/18 mA) on all I/O pins • Configurable open-drain output on digital I/O pins • LCD backlight brightness control • 256K EEPROM • Digital MOSFET switches for LCD power and backlight control

USB3201

USB3202

USB3203

Analog Peripherals

- 4-channel 10-bit analog-to-digital converter
- One (1) analog comparator
- 500 KSPS conversion rate
- Conversion available during sleep, idle

External Connectors

- StackableUSB top only
- Mini-B USB
- 6-pin development interface connector
- 10-pin RS232 connector
- 26-pin I/O connector

Internal Electrical interface

- StackableUSB
- USB 1.1 & 2.0 compatible, full-speed
- I2C
- SPI

Debug Interface

6 Pin Debug Connector	
Pin	Signal
1	MCLR#
2	+3.3V
3	GND
4	PGED2
5	PGEC2
6	GND

6 Pin Debug Connector	
Pin	Signal
1	MCLR#
2	+3.3V
3	GND
4	PGED2
5	PGEC2
6	GND

6 Pin Debug Connector	
Pin	Signal
1	MCLR#
2	+3.3V
3	GND
4	PGED2
5	PGEC2
6	GND

I/O Interface

26 Pin I/O Connector			
Pin	Signal	Signal	Pin
1	GND	RB0/CN2/AN0	2
3	GND	RB1/CN3/AN1	4
5	GND	RB2/CN4/AN2/C2IN-	6
7	GND	RB3/CN5/AN3/C2IN+	8
9	GND	RB4/CN6/AN4/C1IN-	10
11	GND	RB8/INT1	12
13	GND	RE9/INT2	14
15	GND	SCK2	16
17	GND	SDI2	18
19	GND	SDO2	20
21	GND	I2C ALERT#	22
23	GND	I2C SCK	24
25	GND	I2C SDA	26

26 Pin I/O Connector			
Pin	Signal	Signal	Pin
1	GND	RB0/CN2/AN0	2
3	GND	RB1/CN3/AN1	4
5	GND	RB2/CN4/AN2/C2IN-	6
7	GND	RB3/CN5/AN3/C2IN+	8
9	GND	RB4/CN6/AN4/C1IN-	10
11	GND	RB8/INT1	12
13	GND	RE9/INT2	14
15	GND	SCK2	16
17	GND	SDI2	18
19	GND	SDO2	20
21	GND	I2C ALERT#	22
23	GND	I2C SCK	24
25	GND	I2C SDA	26

26 Pin I/O Connector			
Pin	Signal	Signal	Pin
1	GND	RB0/CN2/AN0	2
3	GND	RB1/CN3/AN1	4
5	GND	RB2/CN4/AN2/C2IN-	6
7	GND	RB3/CN5/AN3/C2IN+	8
9	GND	RB4/CN6/AN4/C1IN-	10
11	GND	RB8/INT1	12
13	GND	RE9/INT2	14
15	GND	SCK2	16
17	GND	SDI2	18
19	GND	SDO2	20
21	GND	I2C ALERT#	22
23	GND	I2C SCK	24
25	GND	I2C SDA	26

USB3201**USB3202****USB3203****Serial Ports**

10 Pin RS232 Connector			
Pin	Signal	Signal	Pin
1	NC	NC	2
3	RS232_RX	RS232_RTS	4
5	RS232_TX	RS232_CTS	6
7	NC	NC	8
9	GND	NC	10

10 Pin RS232 Connector			
Pin	Signal	Signal	Pin
1	NC	NC	2
3	RS232_RX	RS232_RTS	4
5	RS232_TX	RS232_CTS	6
7	NC	NC	8
9	GND	NC	10

10 Pin RS232 Connector			
Pin	Signal	Signal	Pin
1	NC	NC	2
3	RS232_RX	RS232_RTS	4
5	RS232_TX	RS232_CTS	6
7	NC	NC	8
9	GND	NC	10

LCD Interface

- Not Applicable

- CPU Interface up to 480x272 WQVGA
 - Standard 40-pin, 0.100" male strip header

- RGB Interface up to 480x272 WQVGA
 - Standard 50-pin, 0.100" male strip header

40 Pin CPU Interface Connector			
Pin	Signal	Signal	Pin
1	+3.3V	+3.3V	2
3	LCDPWR (+3.3V)	LCDPWR (+3.3V)	4
5	LCD+	LCD+	6
7	GND	GND	8
9	+5V	+5V	10
11	GND	GND	12
13	LCD-	LCD-	14
15	GND	GND	16
17	GND	GND	18
19	X-	Y-	20
21	X+	Y+	22
23	(RB15)	(RB14)	24
25	Reset (RC1)	CS (RD10)	26
27	WR (RD4)	(RD3)	28
29	RD (RD5)	Command/ Data select (RC2)	30
31	D0 (RE0)	D1 (RE1)	32
33	D2 (RE2)	D3 (RE3)	34
35	D4 (RE4)	D5 (RE5)	36
37	D6 (RE6)	D7 (RE7)	38
39	(RA9)	(RA10)	40

50 Pin RGB Interface Connector			
Pin	Signal	Signal	Pin
1	+3.3V	+3.3V	2
3	LCDPWR (+3.3V)	LCDPWR (+3.3V)	4
5	LCD+	LCD+	6
7	GND	GND	8
9	+5V	+5V	10
11	LCD-	LCD-	12
13	GND	GND	14
15	D0 (R5)	D1 (R4)	16
17	D2 (R3)	D3 (G5)	18
19	D4 (G4)	D5 (G3)	20
21	D6 (B5)	D7 (B4)	22
23	D8 (B3)	D9 (R2)	24
25	D10 (R1)	D11 (R0)	26
27	D12 (G2)	D13 (G1)	28
29	D14 (G0)	D15 (B2)	30
31	D16 (B1)	D17 (B0)	32
33	GPIO0	GPIO1	34
35	GPIO2	GPIO3	36
37	GPIO4	GPIO5	38
39	GPIO6	SHIFT (DCLK)	40
41	FRAME (VSYNC)	LINE (HSYNC)	42
43	CVOUT	PWMOUT	44
45	GPO	DEN	46
47	X+	Y+	48
49	X-	Y-	50

Development Kit

- Base Module including LCD
- Complete Cable Set
- Documentation, schematics, sample software

- Base Module plus LCD
- Complete Cable Set
- Documentation, schematics, sample software

- Base Module plus LCD
- Complete Cable Set
- Documentation, schematics, sample software

Ordering Information:

USB3201 OEM Modules:

USB3201-ST	LCD/Touchscreen and Interface Board with StackableUSB bottom-stacking connector
USB3201-PC	LCD/Touchscreen and Interface Board with Mini-B USB connector for PC connection
CS3201	Complete cable set

USB3202 OEM Modules:

USB3202-ST	CPU LCD/Touchscreen Interface Board (no LCD included) w/ StackableUSB stackthrough connector
USB3202-PC	CPU LCD/Touchscreen Interface Board (no LCD included) w/ Mini-B USB connector for PC connection
CS3202	Complete cable set

USB3203 OEM Modules:

USB3203-ST	RGB LCD/Touchscreen Interface Board (no LCD included) w/ StackableUSB stackthrough connector
USB3203-PC	RGB LCD/Touchscreen Interface Board (no LCD included) with Mini-B USB connector for PC connection
CS3203	Complete cable set

Related Products:

STDOFFUSB	StackableUSB standoff kit
CA4020	RS232 DB9 cable
CA4025†	40-pin ribbon cable
CA4136	A to Mini-B USB cable
CA4142	ICSP Programming/Debug cable
CA5049†	50-pin ribbon cable
CA5051	26-pin ribbon cable
TB50326	26-pin breakout board
TB50540‡	40-pin breakout board
TB50550†	50-pin breakout board

Development Board Kits*

DK3201-ST	LCD/Touchscreen and Interface Board with StackableUSB bottom-stacking connector; Windows-ready development kit
DK3201-PC	LCD/Touchscreen and Interface Board with Mini-B USB connector for PC connection, Windows-ready development kit

Development Board Kits*

DK3202-ST	CPU LCD/Touchscreen and Interface Board with StackableUSB stackthrough connector; Windows-ready development kit
DK3202-PC	CPU LCD/Touchscreen and Interface Board with Mini-B USB connector for PC connection, Windows-ready development kit

Development Board Kits*

DK3203-ST	RGB LCD/Touchscreen and Interface Board with StackableUSB stackthrough connector; Windows-ready development kit
DK3203-PC	RGB LCD/Touchscreen and Interface Board with Mini-B USB connector for PC connection, Windows-ready development kit

*See Development Kit Specifications.

‡For USB3202 only.

† For USB3203 only.