



386EX PC/104 Computer with CompactFlash and PCMCIA SBC1390



Features

- ✓ Small, low cost, ready to run
- ✓ 386EX, 25 or 33MHz
- ✓ Up to 32MB DRAM
- ✓ CompactFlash connector
- ✓ Optional PC Card interface for Wi-Fi, modem, Ethernet, and other I/O
- ✓ Four serial ports
- ✓ Extended temperature range available

The SBC1390 packs a fast 386EX processor with plenty of memory, and copious amounts of storage into a PC/104-sized board. The optional PC Card interface allows many different types of I/O to be added. Wi-Fi (802.11b) cards, modems, or Ethernet interfaces can be plugged into the PC Card slot.

With 1MB of on-board flash, accessible as a read/write disk, and up to 32MB of DRAM, many large programs can be run. However, if additional

storage capacity is required, the CompactFlash connector allows hundreds of megabytes of removable program and data storage.

Four serial ports, five digital I/O lines, three counter/timers, and a watchdog timer mean that the SBC1390 won't require any additional I/O for many applications. However, if additional capabilities are needed, PC/104 expansion allows a wide variety of I/O cards to be stacked on the SBC1390.

Software Support

*DOS emulation, MSDOS 5.0, RTOS
Comm library, CommBLOK™
PID loop library, PidBLOK™,
C, compilers*
[Items above in Section 6]

Compatible Hardware

*PC/104 expansion cards
[Items above in Section 4]
RS232/RS485 devices
Custom*

Mounting/Packaging

*Standoffs, STDOFF01
[Items above in Section 5]
Custom*

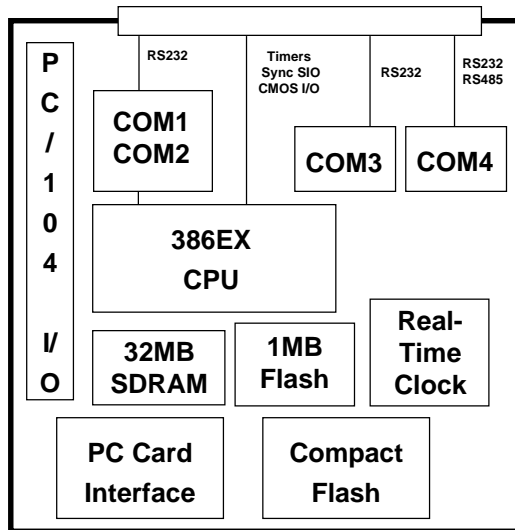

Technical Details:

The SBC1390 core is an Intel 386EX processor running at 25 or 33 MHz. The 386EX allows compatibility with both real mode and 32-bit protected mode programs. The 386EX also integrates many PC-compatible peripherals. Two cascaded 82C59A interrupt controllers, dual 16C450 UARTs, three timer/counters (82C54 compatible), and a two-channel DMA controller are all present. The 386EX also integrates peripherals that are often needed in embedded systems. Bi-directional digital I/O lines, a synchronous serial I/O unit, a chip-select unit, DRAM refresh controller, and a watchdog timer are all packed into the CPU chip.

The optional PC Card (PCMCIA) interface allows many different devices to be plugged into the SBC1390. Wireless networking capability can be added with Wi-Fi (802.11b) cards. A modem can be plugged in to allow remote data or code transfers. Ethernet PC Cards allow connection into a company's wired network. Almost any kind of 16-bit PC Card can be added as long as the operating system supports it. 32-bit

CardBus is not supported.

The memory subsystem on the SBC1390 allows many programs to be run without any external storage. Up to 32 Mbytes of synchronous DRAM (SDRAM) is more than sufficient for many complex, protected-mode programs and operating systems.

The 1-Mbyte Flash memory chip contains both the BIOS and a user application code space. The user space can be configured as a 768k read/write flash disk.

If a larger program or data storage space is required, or if removability is needed, the CompactFlash interface can provide hundreds of megabytes of storage.

The user byte-wide socket can accept a number of different devices. EPROM, 5v Flash, DiskOnChip®, or SRAM can all be plugged in. The SRAM can be battery-backed, which makes for fast storage for data that is updated often.

The socket location is programmable for many different locations both above and below 1 Meg.

Four serial ports allow communication with many different devices. COM1 and COM2 are 16C450-compatible UARTs. COM3 and COM4 are 16C550-compatible UARTs (with transmit and receive FIFOs). All four serial ports are capable of speeds up to 115200 baud, have RS-232 transceivers, and have RTS and CTS modem control lines. Additionally, COM4 is configurable for full-duplex RS-485 communication with jumperable termination resistors.

The PC/104 connector provides support for both 8-bit and 16-bit expansion boards and operates with standard PC/104 bus protocol and timing. The default configuration is non-stackthrough connectors, allowing the SBC1390 to be the bottom card in a stack. The stackthrough option (SBCOPT16ST) allows the SBC1390 to be plugged into a custom-designed OEM I/O board as an automation component.

The SBC1390 can support application development under numerous strategies. If 16-bit DOS or DOS-extended software is sufficient, Micro/sys offers a free DOS-compatible operating system preinstalled on the SBC1390. For a small royalty fee, true MSDOS 5.0 can be preinstalled. Powerful, cost-effective remote debug capabilities are provided through Borland's Turbo Debugger.

For true 32-bit application development, the SBC1390 supports a number of alternatives. Due to its PC compatibility, 32-bit real time operating systems (RTOS) such as PharLap® ETS and VxWorks® can be booted on the SBC1390. All support 32-bit linear protected mode operation, and have full tool suites available, including compilers and debuggers.

For pre-configured sets of options, Micro/sys can provide OEMs with a single part number for ordering. In addition, custom versions of the

SBC1390 are available. Please call Micro/sys Technical Sales for details.

Specifications:

Mechanical:

- PC/104 standard
- 3.55" (plus I/O region) x 3.775" x .6"
- Installed PCMCIA card extends past one side where I/O connector overhang allowed

Power Requirements:

- +5v \pm 5% at TBD max
- +12v required only if used by PC Card or PC/104 modules
- 12v required only if used by PC/104 modules

Environmental:

| Part Number | Airflow | Operating Temp |
|------------------------|-----------|----------------|
| SBC1390 | 0 lfp/m | 0° to +70°C |
| SBC1390-33 | 0 lfp/m | 0° to +60°C |
| SBC1390 with 1390OPT23 | 0 lfp/m | 0° to +60°C |
| SBC1390-33 | 200 lfp/m | 0° to +70°C |
| SBC1390-ET | 230 lfp/m | -40° to +85°C |

- 40° - +85°C storage
- 5%-95% relative humidity, non-condensing

Processor Core Section:

- 386EX CPU
- 25 or 33 MHz clock rate
- Includes three 16-bit timers
- Dual 8259A interrupt controllers
- Selectable DMA support – DRQ2 or DRQ6

On-board Memory:

- 16M DRAM based at 0, expandable to 32M
- 1M of Flash at top of memory map with BIOS and operating system installed; 768k available for user application

Watchdog Timer:

- Program must refresh watchdog timer periodically, or system will be reset
- Enabled through software

COM1-COM4 Serial Ports:

- Four async serial ports, PC compatible
- COM1, COM2 16450-compatible
- COM3, COM4 16550-compatible
- RTS and CTS modem controls
- RS232 on all four channels
- COM4 RS485 full duplex

Synchronous Serial Port:

- One sync serial port, up to 6M baud
- Consists of double-buffered 16-bit RX and TX shift registers, no protocol implemented

Real Time Clock:

- RTC with on-board battery
- Driver software in BIOS
- Optional enhanced accuracy real-time clock is accurate to ± 4 min per year

PC/104 Interface:

- 8-bit and 16-bit PC/104 module support
- IRQ5-7, 9-11, 14, and IOCHCHK (NMI)
- DMA support for DRQ2 or DRQ6

CompactFlash Interface:

- Supports Type I CompactFlash
- Operates in True IDE mode
- CF+ cards not supported
- Not hot-swappable

PC Card Interface Option:

- Supports type I, II, or III
- 82365SL-compatible register set
- Up to five memory windows
- Up to two I/O windows
- 16-bit cards supported
- CardBus not supported

DK1390 Development Kit:

- Free with first SBC1390 purchase
- Breakout cables to COM1-COM4
- Download cable and utilities
- Power cable pigtail
- Documentation, schematics, sample software

External Connections:

- 50-pin header for COM1-COM4, Sync serial port, timer 2, and digital I/O
- 10-pin header for power input

| J2 Main I/O Connector | | | |
|--------------------------|-----------------|----------------|-----|
| Pin | Signal | Signal | Pin |
| 1 | RX COM1 | RTS COM1 | 2 |
| 3 | TX COM1 | CTS COM1 | 4 |
| 5 | N/C | N/C | 6 |
| 7 | GND | RX COM2 | 8 |
| 9 | RTS COM2 | TX COM2 | 10 |
| 11 | CTS COM2 | N/C | 12 |
| 13 | N/C | GND | 14 |
| 15 | RX COM3 | RTS COM3 | 16 |
| 17 | TX COM3 | CTS COM3 | 18 |
| 19 | N/C | N/C | 20 |
| 21 | GND | RX COM4 | 22 |
| 23 | RTS COM4 | TX COM4 | 24 |
| 25 | CTS COM4 | N/C | 26 |
| 27 | N/C | GND | 28 |
| 29 | GND | TX+ COM4 RS485 | 30 |
| 31 | TX- COM4 RS485 | RX+ COM4 RS485 | 32 |
| 33 | RX- COM4 RS485 | N/C | 34 |
| 35 | PC CARD SPEAKER | GND | 36 |
| 37 | Sync TX CLK | Sync TX Data | 38 |
| 39 | Sync RX CLK | Sync RX Data | 40 |
| 41 | GND | Timer 2 CLK | 42 |
| 43 | Timer 2 Gate | Timer 2 OUT | 44 |
| 45 | DIO P11 | DIO P36 | 46 |
| 47 | DIO P10 | DIO P13 | 48 |
| 49 | DIO P31 | GND | 50 |

| J5 Power Connector | | | |
|-------------------------------|---------------|---------------|------------|
| Pin | Signal | Signal | Pin |
| 1 | +5V | +5V | 2 |
| 3 | +12V | +12V | 4 |
| 5 | -12V | -12V | 6 |
| 7 | Ext Batt | GND | 8 |
| 9 | GND | GND | 10 |

CommBLOK, PidBLOK, trademark Drumlin
 IBM, PC trademark IBM Corp.
 MSDOS, Microsoft trademark Microsoft Corp.
 Turbo Debugger trademark Borland International
 DiskOnChip® trademark M-Systems

Ordering Information:

Single Board Computer:

| | |
|------------|---|
| SBC1390 | 386EX CPU, 25MHz, 16MB RAM, 1MB Flash |
| SBC1390-33 | 386EX CPU, 33MHz, 16MB RAM, 1MB Flash |
| SBC1390-ET | 386EX CPU, 25MHz, 16MB RAM, 1MB Flash, extended temp operation |
| DK1390 | No charge development kit, available with first order only |
| 1390OPT2 | 32MB RAM total |
| 1390OPT15 | Enhanced accuracy, extended temp real-time clock, can be installed on SBC1390 or SBC1390-ET |
| 1390OPT23 | PCMCIA (PC Card) slot, 0°C - 70°C operation only |

Accessories:

| | |
|-------------|---|
| CA4045 | Power connector pigtail, 18" |
| CA4092 | Breakout cable for COM1-COM4, Sync serial port, digital I/O |
| TB1485-1 | RS485 Breakout board, use with CA 4092 |
| RAM128 | 128k RAM device |
| RAM512 | 512k RAM device |
| SBCOPT16ST | Stackthrough PC/104 |
| PCC-WIFI11B | 802.11b Wireless PCMCIA card |
| CF-FL128 | 128MB CompactFlash Card |
| CF-FL256 | 256MB CompactFlash Card |
| CF-FL512 | 512MB CompactFlash Card |