



Advanced 486/586 PC/104 Embedded PC SBC1491

Features



- ✓ Ready to run 486/586 computer
- ✓ Small PC/104 format
- ✓ DiskOnChip®, 64MB RAM
- ✓ On-board accelerated VGA
- ✓ COM1, COM2, KBD, mouse
- ✓ 10BASE-T Ethernet port
- ✓ PC/104 expansion
- ✓ -40°C to +85°C operation available

The SBC1491 is an advanced, highly integrated 486/586 embedded PC in the small, PC/104-sized standard. It offers an exceptionally large memory capacity of 64MB, and up to 576MB of flash. In addition to the core processor and memory section, an ample mix of serial, keyboard, VGA, and Ethernet ports provides single board solutions to many design challenges. In its “stackthrough” version, the SBC1491 is an ideal computer to plug into a custom OEM I/O card. The SBC1491-ET version is rugged and fully qualified for -40°C to +85°C operation.

This powerful computer offers a wide range of operating system choices. It runs Windows CE, Linux, DOS, and well-known real time operating system packages. With 1MB of on-board flash accessible as a read/write disk, and 64MB of SDRAM, many large programs can be run. If additional storage capacity is required, the Jedec Socket allows hundreds of megabytes of removable program and data storage. And, if additional capabilities are needed, PC/104 expansion allows a wide variety of I/O cards to be stacked on the SBC1491.

Software Support

*DOS emulation, MSDOS,
Linux, Windows CE, RTOS,
Comm Library, CommBLOK™,
PID loop library, PidBLOK™,
C, compilers*
[Items above in Section 6]

Compatible Hardware

PC/104 expansion cards
[Items above in Section 4]
RS232/RS485 devices
Custom

Mounting/Packaging

Standoffs, STDOFF01
[Items above in Section 5]
ENC104-2
ENC104-4
[Items above in Section 3]
Custom

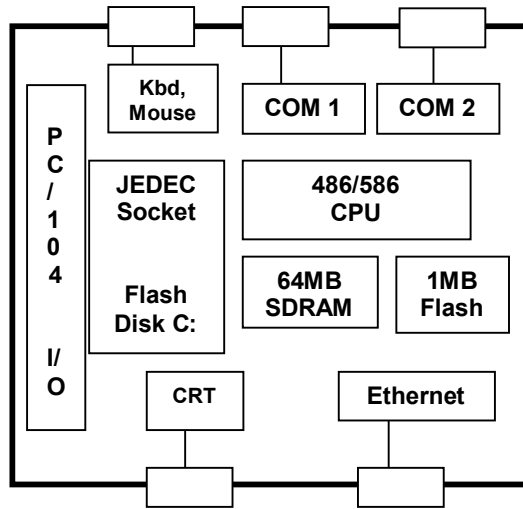

Technical Details:

The SBC1491 core is an ST Microelectronics STPC Atlas processor running at 120 or 133 MHz. The STPC 486DX processor core is clocked at a rate of 133MHz, and includes hardware floating point math. While other 486DX systems access RAM with a 32-bit data bus, the Atlas accesses RAM with a 64-bit wide data bus, offering performance similar to low-end Pentium-based designs.

The Atlas allows compatibility with both real mode and 32-bit protected mode programs. The Atlas also integrates many PC-compatible peripherals. Dual USB ports, a keyboard and mouse controller, an EIDE controller, two cascaded 82C59A interrupt controllers, dual 16C550 UARTs, three timer/counters (82C54 compatible), and a dual DMA controller are all present. A hardware accelerated VGA controller, with support for both CRTs and TFT panels, is also implemented.

The memory subsystem on the SBC1491 allows many programs to be run without any external

storage. 64 Mbytes of synchronous DRAM (SDRAM) is more than sufficient for many complex, protected-mode programs and operating systems.

The 1-Mbyte Flash memory chip contains both the BIOS and a user application code space. The user space can be configured as a 768k read/write flash disk.

A 32-pin JEDEC socket on the SBC1491 can be used to implement non-volatile storage. For large capacity solid state read/write disk requirements, a DiskOnChip flash device can provide a solid state disk. Loading of operating systems and applications, and updating configuration files is ideal for flash disks.

The VGA controller supports resolutions up to 1024 x 1024. It includes hardware acceleration for fast graphic updates. The output can drive a standard RGB CRT monitor.

Two serial ports allow communication with many different devices. COM1 and COM2 are 16C550-compatible UARTs (with transmit and receive FIFOs). These serial ports are capable of speeds up to 115200 baud, have RS-232 transceivers, and have RTS and CTS modem control lines. Additionally, COM1 is configurable for half-duplex RS-485 communication with jumperable termination resistors.

The PC/104 connector provides support for both 8-bit and 16-bit expansion boards and operates with standard PC/104 bus protocol and timing. The default configuration is non-stackthrough connectors, allowing the SBC1491 to be the bottom card in a stack. The stackthrough option (SBCOPT16ST) allows the SBC1491 to be plugged into a custom-designed OEM I/O board as an automation component.

The SBC1491 can support application development under numerous strategies. If 16-bit DOS or DOS-extended software is sufficient, Micro/sys offers a free DOS-compatible operating system preinstalled on the SBC1491. For a small royalty fee, true MSDOS 5.0 can be preinstalled. Powerful, cost-effective remote debug capabilities are provided through Borland's Turbo Debugger.

For true 32-bit application development, the SBC1491 supports a number of alternatives. Due to its PC compatibility, 32-bit real time operating systems (RTOS) such as Linux, PharLap® ETS, and VxWorks® can be booted on the SBC1491. All support 32-bit linear protected mode operation, and have full tool suites available, including compilers and debuggers.

The firmware suite that is preinstalled in flash on the SBC1491 includes an industrial BIOS that allows configuration of many of its features. In addition to allowing configuration of the normal PC-compatible peripherals such as floppy drives and hard drives, it allows 768k of the system flash to be used as a read/write wear-leveled flash

drive. Another feature of the BIOS is its ability to redirect the console out COM1, COM2, or the VGA/keyboard so that even "headless" systems can have a user console when needed for configuration or debug.

For pre-configured sets of options, Micro/sys can provide OEMs with a single part number for ordering. In addition, custom versions of the SBC1491 are available. Please call Micro/sys Technical Sales for details.

Specifications:

Mechanical:

- PC/104 standard
- 3.55" (plus I/O region) x 3.775" x .6"
- If installed, Ethernet connector on top side has height of .535"

Power Requirements:

- +5V ± 5% at 1.3A typical, 1.8A max
- +12v required only if used by PC/104 modules

Environmental:

Part number	Board Airflow *	Operating Temp.
SBC1491	0 cfm	0° to +48°C
SBC1491	17 cfm	0° to +70°C
SBC1491-ET	0 cfm	-40° to +85°C

* Using 80mm fan

- 40° to +85°C storage
- 5%-95% relative humidity, non-condensing

Power Connector			
Signal	Pin	Pin	Signal
+5V	1	2	+5V
+12V	3	4	+12V
-12V	5	6	Key
VBATT	7	8	GND
GND	9	10	GND

Processor Core Section:

- STPC Atlas CPU
- 120 or 133 MHz clock rate
- Hardware floating point math
- AT-compatible timers, interrupts, DMA

On-board Memory:

- 64M Synchronous DRAM based at 0
- 1M of Flash at top of memory map with BIOS and operating system installed; 768k available for user application
- JEDEC 32-pin socket for DiskOnChip
- Surface mounted DRAM and SRAM IC's for ruggedness

Watchdog Timer:

- Program must refresh watchdog timer periodically, or system will be reset
- Enabled through software

Keyboard, Mouse, and Speaker:

- PS/2-compatible keyboard port
- PS/2-style mouse port
- AT-compatible TTL speaker output

RS485, Keyboard, Mouse Connector			
Signal	Pin	Pin	Signal
GND	1	2	+TX485
-TX485	3	4	+RX485
-RX485	5	6	
	7	8	+5V
	9	10	GND
GND	11	12	MCLK
MDATA	13	14	+5V
+5V	15	16	KDATA
KCLK	17	18	SPKR
RED	19	20	GND

SVGA Video Output:

- CRT output
- Resolutions to 1280 x 1024

VGA/CRT Connector			
Signal	Pin	Pin	Signal
--	1	2	
--	3	4	GND
VSYNC	5	6	GND
HSYNC	7	8	GND
BLUE	9	10	GND
GREEN	11	12	GND
RED	13	14	GND

COM1-COM2 Serial Ports:

- Two async serial ports, PC compatible
- 16550-compatible
- RTS and CTS modem controls
- RS232 on both channels
- COM1 RS485 Full duplex

CPU Serial Port Connector		
Pin	Direction	Signal
1		
2		
3	I	RXD
4	O	RTS
5	O	TXD
6	I	CTS
7		
8		
9	-	GND
10		

Real Time Clock:

- RTC with on-board battery
- .002% accuracy on -ET version
- Driver software in BIOS

PC/104 Interface:

- Non-Stackthrough PC/104 connectors
- Standard mounting holes
- 8 and 16-bit PC/104 module support
- Full IRQ and DRQ support
- Stackthrough option available (SBCOPT16ST)

DK1491 Development Kit:

- Free with first SBC1491 purchase
- Breakout cable to COM1
- Breakout cable to CRT
- Breakout cable to keyboard, mouse, speaker
- Download cable and utilities
- Documentation, schematics, sample software

External Connections:

- 10-pin header for COM1
- 10-pin header for COM2
- 20-pin header for COM1 RS485/KBD/Mouse
- 14-pin header for CRT
- 10-pin header for power input

Ordering Information:

Single Board Computer:

- | | |
|----------------|--|
| SBC1491 | 486/586 CPU, 133MHz,
64MB RAM, 1M Flash |
| SBC1491-ET | 486/586 CPU, 120MHz,
64MB RAM, 1M Flash, -40°
to +85°C operating
temperature |
| DK1491 | No charge development kit,
available with first order only |
| SDK-Linux-1491 | Linux Kit (must also
purchase 1491OPT50) |
| SDK-WinCE-1491 | WinCE 5.0 Development Kit |
| Netsock/435 | SBC1491 with Ethernet and
UDP/IP, 66Mhz (refer to
separate data sheet) |
| Netsock/435-ET | Extended temperature
version |
| 1491OPT3 | 512KB battery-backed RAM |
| 1491OPT4 | 1MB battery-backed RAM |
| 1491OPT20 | 10Base-T Ethernet |
| 1491OPT25 | MS-DOS 6.22 in Bootable
Flash ROMdisk A: |
| 1491OPT50 | Linux startup kernel installed
in flash |
| SBC1490-ATL | Call factory for ordering
information on
SBC1490-ATL. Drop-in
replacement for SBC1490 |

Add -ET to option for extended temp operation

Related Products:

- | | |
|--------|---|
| MPC405 | Floppy, IDE interface PC/
104 board |
| CA4020 | 10-pin to male DB9
connector |
| CA4030 | VGA Monitor DB15 Breakout
Cable |
| CA4035 | Debug and Download Cable |
| CA4045 | Power Cable |
| CA4052 | Breakout Cable for KBD,
Mouse, Speaker, RS485, |

	and COM1
KA1010-1	KBD, Mouse, and Speaker Breakout Board
SBCOPT16ST	Stackthrough PC/104
DC32	32MB DiskOnChip
DC64	64MB DiskOnChip
DC96	96MB DiskOnChip
DC128	128MB DiskOnChip
DC256	256MB DiskOnChip
DC384	384MB DiskOnChip
DC576	576MB DiskOnChip
ENC104-2	Subfloor
ENC104-4	Enclosure

Cables nominally 15", other lengths available

CommBLOK, PidBLOK, trademark Drumlin
MSDOS, Microsoft trademark Microsoft Corp.
Turbo Debugger trademark Borland International
VxWorks trademark Wind River