

Micro/sys Spartan 6 FPGA/ARM Cortex-A8 Development Kit

Development Kit Features:

- Select one of three pre-defined development modes or define your own:
 - 95% of FPGA core available for user's firmware
 - MicroBlaze implementation examples
- Professional Xilinx tool chains
 - ISE Design Suite
 - EDK Design Software
- Fast memory bus interface between Spartan 6 & i.MX515
 - Expand SBC feature set with IP cores such as SATA, DSP, video, etc.
 - FPGA to i.MX515 IRQs available
- Two options for field deployment
 - Port FPGA firmware to user-designed hardware
 - Keep FPGA firmware on development SBC for OEM production

Standalone SBC Features:

- ARM Cortex-A8, 800MHz
- 512MB SDRAM, 4MB SPI NOR Flash
- Four (4) USB ports
- Dual 10/100BASE-T Ethernet
- 7 serial ports (RS232 and RS485)
- Two (2) SD/MMC card slots
- 64 bits of digital I/O
- Popular StackableUSB™ expansion bus
- Linux and WindowsCE BSPs
- OEM pricing options available

Target Applications:

- Military
- Automation
- Medical
- Transportation
- Energy
- Communication



Flexible Development Platform:

The DK-FPGA1651 is a turn-key single-board-computer development environment for the Xilinx Spartan 6 FPGA aimed at accelerating development of FPGA-based applications, from the simplest to the most complex. For fastest time-to-market, designers can integrate their FPGA firmware onto the robust COTS platform of the DK-FPGA1651 and integrate the same SBC directly into their run-time application. While for designers needing easy portability, the DK-FPGA1651 becomes a valuable tool for developing and debugging FPGA application code or integrating IP cores with the ultimate goal of porting to one's own user-designed hardware.

The COTS Advantage:

The Micro/sys DK-FPGA1651 skillfully integrates the Xilinx Spartan 6 onto an off-the-shelf SBC based on the Freescale i.MX515 ARM Cortex-A8. After the SBC serves as a development station for user FPGA developed IP, the same SBC can be used in a final OEM application. This COTS approach to FPGA development offers the OEM user an SBC with a 15-year lifecycle and enhanced adaptability for product expansion, updates, and customized version control in the final OEM application achieved simply via FPGA programming. Customizable I/O options range from simple I/O and expanded communication protocols to multi-processing and video expansion.



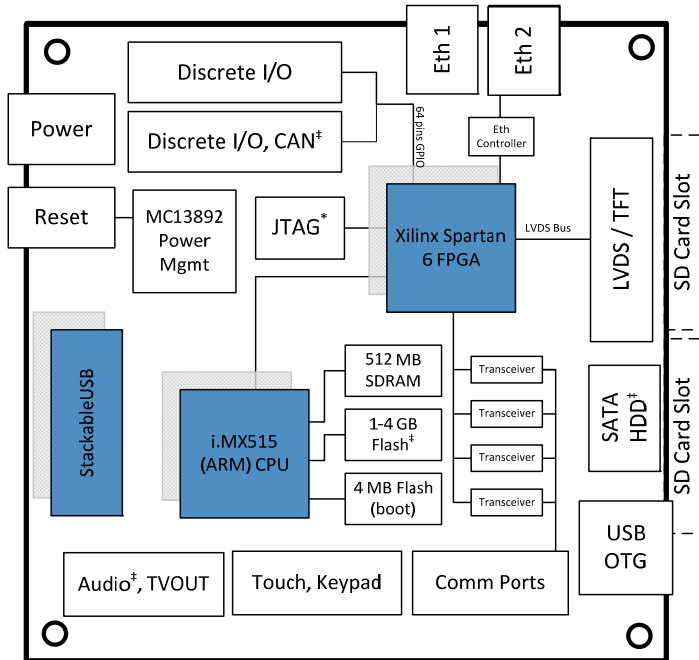

* No emulator required.

† Optional Installation

‡ LVDS signals available when LVDS panel support is disabled

Turn-key Development Platform:

With all the necessary components to immediately start development with the Spartan 6, this turn-key kit solves the problem of hardware and software integration allowing designers to focus on building differentiating features into their end application. Designers profit from the easy-to-use Xilinx ISE Design Suite: Embedded Edition (including the EDK design software) and vast selection of validated IP cores as well as Micro/sys's embedded system expertise to shorten design time and gain smarter methodologies for creating FPGA-based solutions. In addition, the DK-FPGA1651 comes with multiple on-board connectivity options including 64 lines of bi-directional GPIO signals, four pre-validated transceivers for RS232/RS485, and five differential LVDS signals for user-defined configuration[†]. These added features allow easy addressing and decoding for customized protocols by enabling designers to interface a 32-bit data bus as well as addressing lines for a variety of IP cores via the 64 GPIO lines. Typical functions for such features might be real time video, motion control, or industrial Ethernet.

Development Kit Includes:

Board

- SBC1651 (Linux or WinCE BSP)

Tools & IP

- Xilinx ISE software (free download from Xilinx)
- Xilinx EDK evaluation software (downloadable from Xilinx)
- Micro/sys interface code to the Freescale WEIM bus for direct communication btw CPU & FPGA

Targeted Reference Designs & Demos

- How to implement MicroBlaze.
- How to install COM ports w/ free IP.
- How to implement drivers to COM port IP.
- How to implement DIO and drivers.

Documentation

- DK-FPGA1651 Getting Started Guide
- DK-FPGA1651 Hardware User Manual
- DK-FPGA1651 Reference Design User Guide

Cables and Adapters

- 5V wall-mount power supply
- Xilinx Platform Cable USB-II
- 4 GB Solid State Drive (SSD)
- RJ45 Ethernet Cable
- Mini B to Type A USB Cable
- 20-pin high density to 20-pin screw terminal
- 40-pin high density to 40-pin screw terminal
- 50-pin high density to 50-pin screw terminal
- Industrial enclosure
- Power supply
- Graphical Runtime kit includes panel

Micro/sys, Inc.

3730 Park Place

Montrose, CA 91020

P: 818-244-4600

E: sales@embeddedsys.com

www.embeddedsys.com