



# XScale StackableUSB™ Computer With Dual Ethernet SBC1626

## Features



- ✓ Industry's first StackableUSB Low-power ARM
- ✓ 266 to 533MHz clock speed
- ✓ Seven (7) USB ports
- ✓ Dual 10/100BASE-T Ethernet
- ✓ 128MB SDRAM, 64MB Flash
- ✓ CompactFlash connector
- ✓ Four (4) serial ports
- ✓ 24 bits of digital I/O
- ✓ -40° to +85°C operation



The SBC1626 combines a fast Intel XScale RISC processor, lots of memory, and StackableUSB I/O capability on a small 104™ Form Factor board. The power-efficient ARM architecture means the SBC1626 draws little power at its full 533MHz clock speed, thus reducing the power supply and cooling requirements of the board. On-board I/O includes 24 TTL digital I/O lines, dual 10/100BASE-T Ethernet, CompactFlash, and four (4) serial ports.

This powerful XScale board is equipped with the latest innovation in I/O expansion,

StackableUSB. More than five (5) StackableUSB I/O peripheral boards can be connected top and/or bottom side of the board, which allows maximum flexibility in configuring a system's I/O requirements.

With up to 64MB of on-board linear flash and 128MB of SDRAM, high-level operating systems, such as Linux and Windows CE, can be installed. For systems requiring additional storage capacity, the on-board CompactFlash connector provides expansion to standard CompactFlash cards.

### Software/Driver Support

Linux  
Windows CE  
C, compilers

### Compatible Hardware

StackableUSB  
PC hosts

### Mounting/Packaging

Standoffs, STDOFFUSB

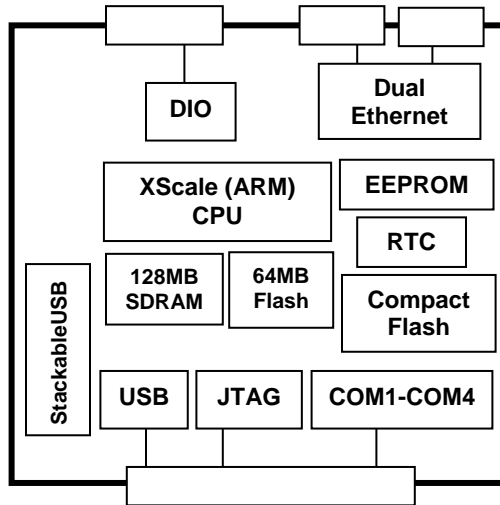

## Technical Details:

The SBC1626 core is an Intel IXP420 or IXP425 XScale processor running at 266 or 533MHz. The Intel XScale processor core is clocked at a rate of 266MHz to 533MHz. This variation of the industry-standard ARM architecture is a RISC processor that is designed for fast Ethernet communication with a built-in dual Ethernet controller.

The IXP42x is compatible with 32-bit operating systems. The IXP42x also integrates many peripherals such as dual USB ports, an interrupt controller, dual 16C550 UARTs, a watchdog timer, and a SDRAM controller.

The memory subsystem on the SBC1626 allows many programs to be run without any external storage. 128Mbytes of SDRAM is more than sufficient for many complex programs and operating systems.

The 64Mbyte flash memory contains the bootloader, operating system, and user application code space. Some of the flash can be allocated as a read/write flash drive.

If a larger program or data storage space is required, or if removability is needed, the CompactFlash interface can provide hundreds of megabytes of storage.

Four (4) serial ports allow communication with many different devices. COM1 through COM4 are 16C550-compatible UARTs (with transmit and receive FIFOs). These serial ports have RS232 transceivers and have RTS and CTS modem control lines. Additionally, COM1 is configurable for half-duplex RS485 communication with jumperable termination resistors.

The SBC1626 becomes a powerful front-end processor for control applications with the standard StackableUSB expansion. This popular I/O channel accommodates up to five (5) I/O boards on the top side and/or the bottom side of the board without use of a hub.

For true 32-bit application development, the SBC1626 supports a number of alternatives. 32-bit operating systems such as Linux, Windows CE, and VxWorks® can be booted

on the SBC1625. All have full tool suites available, including compilers and debuggers.

For pre-configured sets of options, Micro/sys can provide OEMs with a single part number for ordering. In addition, custom versions of the SBC1626 are available. Please call Micro/sys Technical Sales for details.

## Specifications:

### Mechanical:

- ❑ PC/104 mounting holes
- ❑ 3.55" (plus I/O region) x 3.775" x .6"
- ❑ Installed CompactFlash card extends past edge of board opposite the StackableUSB connector
- ❑ If installed, Ethernet connector on top side has height of .453". Components on the bottom side have a maximum height of .134".

### Power Requirements:

- ❑ +5v  $\pm$ 5% at 385mA typical, 770mA max
- ❑ +12v required only if used by PC/104 modules

Power Connector	
Pin	Signal
1	+5V
2	+12V
3	GND

### Environmental:

- ❑ Operating range 0° to +70°C
- ❑ ET-version operating range -40° to +85°C
- ❑ -40° to +85°C storage
- ❑ 5%-95% relative humidity, non-condensing

### Processor Core Section:

- ❑ Intel IXP425 or IXP420
- ❑ 266 or 533MHz clock rate
- ❑ StrongARM v5TE instruction set

### On-board Memory:

- ❑ 64-128MB Synchronous DRAM based at address 0
- ❑ 16-64MB of linear flash for bootloader, operating system, and application

### Watchdog Timer:

- ❑ Program must refresh watchdog timer periodically, or system will be reset
- ❑ Enabled through software

### COM1-COM4 Serial Ports:

- ❑ Four (4) async serial ports
- ❑ 16C550-compatible
- ❑ RTS and CTS modem controls
- ❑ RS232 on all channels
- ❑ COM2 RS485 half duplex

### 10/100BASE-T Ethernet Ports:

- ❑ Two (2) 10/100Base-T Ethernet ports
- ❑ Auto MDIX allows automatic switching of twisted pair input and output
- ❑ Standard RJ45 connectors

### USB:

- ❑ Two (2) USB 1.1, hosts/clients, Type A connector
- ❑ Five (5) USB 2.0, hosts, StackableUSB connector
- ❑ Device or function controller only. USB controller does not operate as a host
- ❑ Transfers at high-speed 480Mbit/sec, full-speed 12Mbit/sec, or 1.5Mbit/sec

### Real Time Clock:

- ❑ RTC with on-board battery
- ❑ Driver software in BIOS

### Digital I/O:

- ❑ 24 TTL bi-directional signals
- ❑ 82C55 digital I/O chip
- ❑ Direction programmable in two (2) groups of eight bits and two (2) groups of four bits
- ❑ Eight (8) LEDs on port B
- ❑ Octal DIP switch on port A
- ❑ 470-ohm current-limiting resistors on all lines

**JTAG Interface:**

- Debug unit has hardware break points and 256-entry trace history buffer
- IEEE 1149.1 JTAG compatible

Digital I/O Connector			
Pin	Signal	Signal	Pin
1	DIOA0	DIOA1	2
3	DIOA2	DIOA3	4
5	DIOA4	DIOA5	6
7	DIOA6	DIOA7	8
9	DIOB0	DIOB1	10
11	DIOB2	DIOB3	12
13	DIOB4	DIOB5	14
15	DIOB6	DIOB7	16
17	DIOC0	DIOC1	18
19	DIOC2	DIOC3	20
21	DIOC4	DIOC5	22
23	DIOC6	DIOC7	24
25	GND	GND	26

**CompactFlash Interface:**

- Supports Type I or II CompactFlash
- Not hot-swappable

**Development Kit:**

- SBC with all options installed
- Complete cable set
- Documentation, schematics, sample software

**External Connections:**

- 40-pin header for COM1-COM4, USB, JTAG
- Two (2) 8-pin modular RJ45 jacks for Ethernet
- 26-pin header for digital I/O
- 2-pin locking header for reset
- 3-pin removable terminal strip for power input

Main I/O Connector			
Pin	Signal	Signal	Pin
1	RX COM3	RTS COM3	2
3	TX COM3	CTS COM3	4
5	-	-	6
7	GND	RX COM4	8
9	RTS COM4	TX COM4	10
11	CTS COM4	-	12
13	-	GND	14
15	RX COM1	RTS COM1	16
17	TX COM1	CTS COM1	18
19	-	-	20
21	GND	RX COM2	22
23	RTS COM2	TX COM2	24
25	CTS COM2	-	26
27	-	GND	28
29	RS485-	RS485+	30
31	GND	USB-	32
33	USB+	TRST_N	34
35	TDO	TMS	36
37	+3.3V	TCK	38
39	TDI	RST_N	40

## Ordering Information:

### OEM Single Board Computers:

SBC1626	IXP420 CPU, 266MHz, 64MB RAM, 16MB Flash, dual Ethernet
SBC1626-533	IXP420 CPU, 533MHz, 64MB RAM, 16MB Flash, dual Ethernet
SBC1626-ET	IXP420 CPU, 266MHz, 64MB RAM, 16MB Flash, dual Ethernet, -40° to +85°C operating temp
SBC1626-533-ET	IXP425 CPU, 533MHz, 64MB RAM, 16MB Flash, dual Ethernet, -40° to +85°C operating temp
CS1626	Complete Cable Set
1626OPT3	128MB SDRAM
1626OPT5	32MB Flash
1626OPT6	64MB Flash

### Related Products:

CA4107	Breakout cable to four (4) DB9 COM port connectors
BA4107	Breakout assembly to four (4) DB9 COM port connectors, RS485, USB, JTAG
CA5051	26-pin to 26-pin ribbon cable for digital I/O
BA0026	Breakout assembly to 26- position terminal strip. (Includes CA5051 and TB50326)
CF-FL2G	2G CompactFlash Card
USB3368	8 port USB adapter board with StackableUSB stackthrough connector

Cables nominally 15", other lengths available  
VxWorks trademark Wind River

### Development Board Kits\*

DK1626-ET-x86	IXP420 CPU, 266MHz, 64MB RAM, 16MB Flash, dual Ethernet, - 40° to +85°C operating temp, DOS-installed Windows-ready development kit
DK1626-ET-WinCE	IXP420 CPU, 266MHz, 64MB RAM, 16MB Flash, dual Ethernet, -40° to +85°C operating temp, WinCE-ready development kit
DK1626-ET-Linux	IXP420 CPU, 266MHz, 64MB RAM, 16MB Flash, dual Ethernet, -40° to +85°C operating temp, Linux-ready development kit
DK1626-533-ET-x86	IXP420 CPU, 533MHz, 64MB RAM, 16MB Flash, dual Ethernet, -40° to +85°C operating temp, DOS-installed Windows-ready development kit
DK1626-533-ET-WinCE	IXP420 CPU, 533MHz, 64MB RAM, 16MB Flash, dual Ethernet, -40° to +85°C operating temp, WinCE-ready development kit
DK1626-533-ET-Linux	IXP420 CPU, 533MHz, 64MB RAM, 16MB Flash, dual Ethernet, -40° to +85°C operating temp, Linux-ready development kit

\*See Development Kit Specifications