

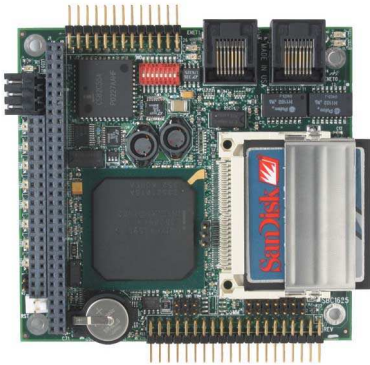

XScale PC/104 Computer with Dual Ethernet SBC1625



Features

- ✓ Low-power ARM processor
- ✓ 266 to 533MHz clock speed
- ✓ Dual 10/100BASE-T Ethernet
- ✓ 128MB SDRAM, 64MB Flash
- ✓ CompactFlash connector
- ✓ Four serial ports
- ✓ 24 bits of digital I/O
- ✓ Extended temperature available

The SBC1625 packs a fast Intel XScale RISC processor with lots of memory into a PC/104-sized board. The efficient, industry-standard ARM architecture allows the SBC1625 to draw little power at its full 533MHz clock speed. This reduces power supply and cooling requirements. Onboard I/O includes 24 TTL digital I/O lines, four serial ports, dual 10/100BASE-T Ethernet, USB, and CompactFlash.

In its stackthrough version, the SBC1625 is an ideal computer to plug into a custom OEM I/O

card. Immediately and easily, an advanced engine is available for software development.

With up to 64MB of onboard linear flash, and 128MB of SDRAM, many complex operating systems, such as Linux and Windows CE can be run. However, if additional storage capacity is required, the CompactFlash connector allows hundreds of megabytes of removable storage.

And, if additional capabilities are needed, PC/104 expansion allows a wide variety of I/O cards to be stacked on the SBC1625

Software Support

Linux
Windows CE
VxWorks®
RTOS
C, compilers
[Items above in Section 6]

Compatible Hardware

PC/104 expansion cards
[Items above in Section 4]
RS232/RS485 devices
Custom

Mounting/Packaging

Standoffs, STDOFF01
[Items above in Section 5]
Custom

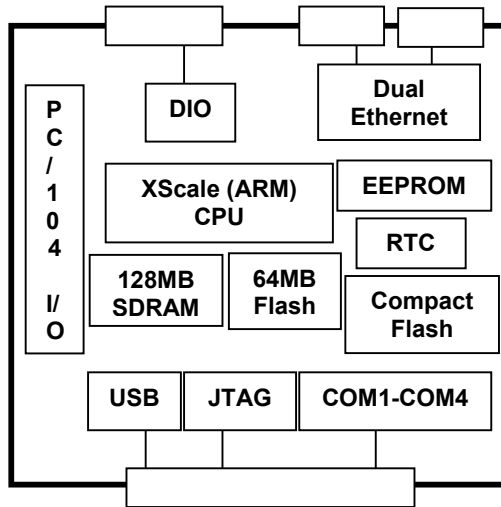

Technical Details:

The SBC1625 core is an Intel IXP425 or IXP420 XScale processor running at 266 or 533 MHz. The Intel XScale processor core is clocked at a rate of 266MHz to 533MHz. This variation of the industry-standard ARM architecture is a RISC processor that is designed for fast Ethernet communication and has a dual Ethernet controller built in.

The IXP42x allows compatibility with 32-bit operating systems. The IXP42x also integrates many peripherals. Dual USB ports, an interrupt controller, dual 16C550 UARTs, a watchdog timer, and an SDRAM controller are all present.

The memory subsystem on the SBC1625 allows many programs to be run without any external storage. 128 Mbytes of synchronous DRAM (SDRAM) is more than sufficient for many complex programs and operating systems.

The 64-Mbyte Flash memory contains the bootloader, operating system, and user

application code space. Some of the flash can be allocated as a read/write flash drive.

If a larger program or data storage space is required, or if removability is needed, the CompactFlash interface can provide hundreds of megabytes of storage.

Four serial ports allow communication with many different devices. COM1 through COM4 are 16C550-compatible UARTs (with transmit and receive FIFOs). These serial ports have RS-232 transceivers, and have RTS and CTS modem control lines. Additionally, COM2 is configurable for half-duplex RS-485 communication with jumperable termination resistors.

The PC/104 connector provides support for both 8-bit and 16-bit I/O expansion boards. The default configuration is non-stackthrough connectors, allowing the SBC1625 to be the bottom card in a stack. The stackthrough option (SBCOPT16ST)

allows the SBC1625 to be plugged into a custom-designed OEM I/O board as an automation component.

For true 32-bit application development, the SBC1625 supports a number of alternatives. 32-bit operating systems such as Linux, Windows CE, and VxWorks® can be booted on the SBC1625. All have full tool suites available, including compilers and debuggers.

For pre-configured sets of options, Micro/sys can provide OEMs with a single part number for ordering. In addition, custom versions of the SBC1625 are available. Please call Micro/sys Technical Sales for details.

Specifications:

Mechanical:

- PC/104 standard
- 3.55" (plus I/O region) x 3.775" x .6"
- Installed CompactFlash card extends past edge of board opposite the PC/104 connector
- If installed, Ethernet connector on top side has height of .453". Components on the bottom side have a maximum height of .134".

Power Requirements:

- +5v \pm 5% at 385mA typical, 770mA max
- +12v required only if used by PC/104 modules

Environmental:

- Operating range 0° to +70°C
- ET-version operating range -40° to +85°C
- 40° to +85°C storage
- 5%-95% relative humidity, non-condensing

Power Connector	
Pin	Signal
1	+5V
2	+12V
3	GND

Processor Core Section:

- Intel IXP425 or IXP420
- 266 or 533 MHz clock rate
- StrongARM v5TE instruction set

On-board Memory:

- 64-128MB Synchronous DRAM
- 16-64MB of linear flash for bootloader, operating system, and application

Watchdog Timer:

- Program must refresh watchdog timer periodically, or system will be reset
- Enabled through software

COM1-COM4 Serial Ports:

- Four async serial ports
- 16C550-compatible
- RTS and CTS modem controls
- RS232 on all channels
- COM2 RS485 half duplex

10/100BASE-T Ethernet Ports:

- Two 10/100 Ethernet ports
- Auto MDIX allows automatic switching of twisted pair input and output
- Standard RJ45 connectors

Real Time Clock:

- RTC with on-board battery
- Driver software in BIOS

Digital I/O:

- 24 TTL bi-directional signals
- 82C55 digital I/O chip
- Direction programmable in two groups of eight bits and two groups of four bits
- Eight LEDs on port B
- Octal DIP switch on port A
- 470-ohm current-limiting resistors on all lines

Digital I/O Connector			
Pin	Signal	Signal	Pin
1	DIOA0	DIOA1	2
3	DIOA2	DIOA3	4
5	DIOA4	DIOA5	6
7	DIOA6	DIOA7	8
9	DIOB0	DIOB1	10
11	DIOB2	DIOB3	12
13	DIOB4	DIOB5	14
15	DIOB6	DIOB7	16
17	DIOC0	DIOC1	18
19	DIOC2	DIOC3	20
21	DIOC4	DIOC5	22
23	DIOC6	DIOC7	24
25	GND	GND	26

JTAG Interface:

- Debug unit has hardware break points and 256-entry trace history buffer
- IEEE 1149.1 JTAG compatible

USB Interface:

- USB v1.1
- Device or function controller only. USB controller does not operate as a host

Main I/O Connector			
Pin	Signal	Signal	Pin
1	RX COM3	RTS COM3	2
3	TX COM3	CTS COM3	4
5	-	-	6
7	GND	RX COM4	8
9	RTS COM4	TX COM4	10
11	CTS COM4	-	12
13	-	GND	14
15	RX COM1	RTS COM1	16
17	TX COM1	CTS COM1	18
19	-	-	20
21	GND	RX COM2	22
23	RTS COM2	TX COM2	24
25	CTS COM2	-	26
27	-	GND	28
29	RS485-	RS485+	30
31	GND	USB-	32
33	USB+	TRST_N	34
35	TDO	TMS	36
37	+3.3V	TCK	38
39	TDI	RST_N	40

PC/104 Interface:

- Non-stackthrough PC/104 connectors
- Standard mounting holes
- 8-bit and 16-bit PC/104 module support
- I/O accesses supported, memory accesses not supported
- Stackthrough option available (SBCOPT16ST)

CompactFlash Interface:

- Supports Type I or II CompactFlash
- Not hot-swappable

DK1625 Development Kit:

- Free with first SBC1625 purchase
- Breakout cable to COM1-COM4
- Download cable and utilities
- Documentation, schematics, sample software

External Connections:

- 40-pin header for COM1-COM4, USB, JTAG
- Two 8-pin modular RJ45 jacks for Ethernet
- 26-pin header for digital I/O
- 2-pin locking header for reset
- 3-pin removable terminal strip for power input

Ordering Information:

Single Board Computer:

- | | |
|-------------|--|
| SBC1625 | IXP420 CPU, 266MHz, 64MB RAM, 16MB Flash, dual Ethernet |
| SBC1625-533 | IXP420 CPU, 533MHz, 64MB RAM, 16MB Flash, dual Ethernet |
| SBC1625-ET | IXP420 CPU, 266MHz, 64MB RAM, 16MB Flash, dual Ethernet, -40° to +85°C operating temperature |

SBC1625-533-ET	IXP425 CPU, 533MHz, 64MB RAM, 16MB Flash, dual Ethernet, -40° to +85°C operating temperature
DK1625	No charge development kit, available with first order only
SDK-Linux-1625	Linux Development kit (must also purchase 1625OPT50)
SDK-WinCE-1625	WinCE Development kit (must also purchase 1625OPT55)
1625OPT3	128MB SDRAM
1625OPT5	32MB Flash
1625OPT6	64MB Flash
1625OPT50	Linux in flash
1625OPT55	WinCE in flash

Related Products:

CA4107	Breakout cable to four DB9 COM port connectors
BA4107	Breakout assembly to four DB9 COM port connectors, RS485, USB, JTAG
CA5051	26-pin to 26-pin ribbon cable for digital I/O
BA0026	Breakout assembly to 26- position terminal strip. Includes CA5051 and TB50326
SBCOPT16ST	Stackthrough PC/104
CF-FL128	128MB CompactFlash Card
CF-FL256	256MB CompactFlash Card
CF-FL512	512MB CompactFlash Card

Cables nominally 15", other lengths available

VxWorks trademark Wind River