

High Voltage Opto-diode - Axial Lead

Original Released: 03-06-09
 Revised Date: 12-26-12

0.5 A • 3000ns

ELECTRICAL CHARACTERISTICS AND MAXIMUM RATINGS														
Part Number	Working Reverse Voltage (V _{rw})	Average Rectified Current (I _o)		Reverse Current @ V _{rw} (I _r)		Forward Voltage (V _f)		1 Cycle Surge Current t _p =8.3ms (I _{fsm})	Repetitive Surge Current (I _{frm})	Reverse Recovery Time (3) (T _{rr})	Thermal Impedance θ _{J-L}			Junction Cap. @50VDC @ 1kHz (C _j)
		55 °C(1)	100 °C(2)	25 °C	100 °C	25 °C		25 °C	25 °C	25 °C	25 °C	L=000	L=.125	L=.250
	Volts	Amps	Amps	µA	µA	Volts	Amps	Amps	Amps	ns	°C/W	°C/W	°C/W	pF
OZ100SG	10000	0.50	0.25	1.0	25	12.0	0.60	25	5.0	3000	6	9	15	8.0

(1)TL=55°C L=0.375" (2)TL=100°C L=0.375" (3)I_f=0.5A, I_r=1.0A, I_{rr}=0.25A *Op.Temp.= -40°C to +70°C Stg.Temp.= -40°C to +100°C

Markings:
 B VMI
 A OZ100SG
 N D/C
 D

Tolerance:
 XXX ±.010

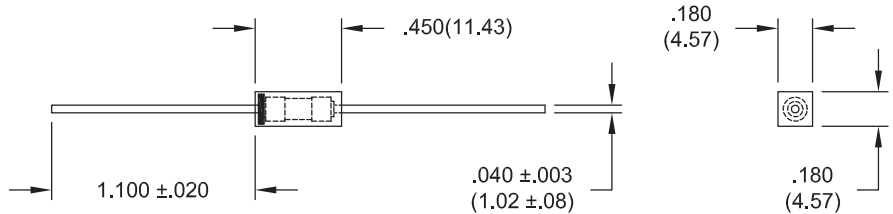

Dimensions: In. (mm) • All temperatures are ambient unless otherwise noted. • Data subject to change without notice.



Voltage Multipliers Inc.

8711 W. Roosevelt Ave.
 Visalia, CA 93291 USA

Tel: 559.651.1402
 Fax: 559.651.0740

www.voltagemultipliers.com
 www.highvoltagepowersupplies.com

OZ100SG

Typical HV Opto-Coupler Configuration

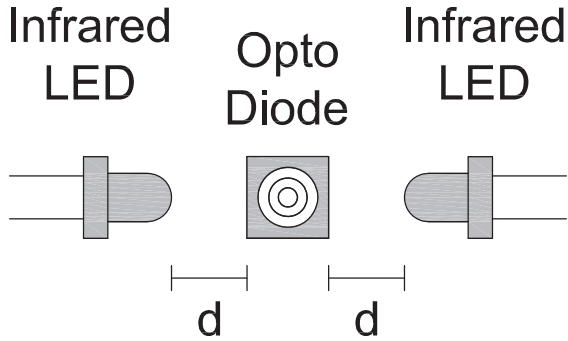

- LEDs placed in close proximity to opto-diode.
- Gain of configuration is determined by:

$$\frac{I_{\text{OPTO}}}{I_{\text{LED}}} \times 100\%$$
- Gain is dependent on:
 - Distance (d) of LEDs from opto-diode.
 - Wavelength of LED light (λ_{LED}).
 - Intensity of LED light (Φ_e).
 - Optical properties of medium between LEDs and opto-diode.

$\lambda_{\text{LED}} = 940 \text{ nm}, \Phi_{e \text{ min}} = 40 \text{ mW/sr}$

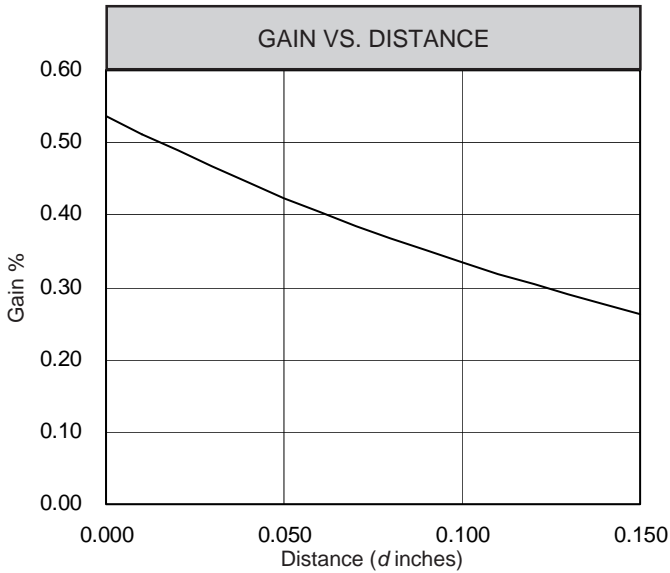

$\lambda_{\text{LED}} = 890 \text{ nm}, \Phi_{e \text{ min}} = 50 \text{ mW/sr}$

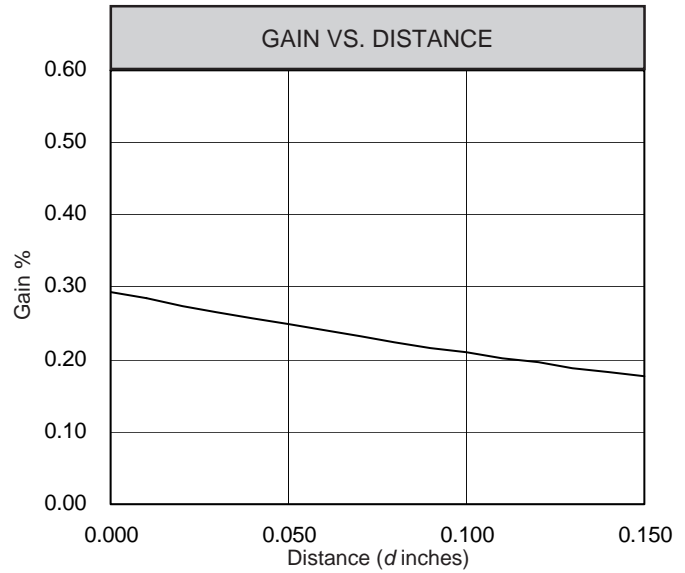

Both configurations use $V_{\text{OPTO}} = 10\text{kV}$ and two LEDs

OZ100SG

