

2,000 V - 5,000 V Rectifiers
1.5 A - 3.5 A Forward Current
70 ns Recovery Time

1N6513LL
1N6515LL
1N6517LL

FORMED LEAD

Original Released: 08-01-99
 Revised Date: 05-17-12



ELECTRICAL CHARACTERISTICS AND MAXIMUM RATINGS

Part Number	Working Reverse Voltage (V _{rw})	Average Rectified Current (I _o)		Reverse Current @ V _{rw} (I _r)		Forward Voltage (V _f)		1 Cycle Surge Current t _p =8.3ms (I _{fsm})	Repetitive Surge Current (I _{frm})	Reverse Recovery Time (3) (T _{rr})	Thermal Impd. θ _{J-C}	Junction Cap. @50VDC @1kHz (C _j)
		55 °C(1)	100 °C(2)	25 °C	100 °C	25 °C	25 °C	25 °C	25 °C	25 °C	25 °C	25 °C
	Volts	Amps	Amps	µA	µA	Volts	Amps	Amps	Amps	ns	°C / W	pF
1N6513LL	2000	3.5	2.4	1.0	25	3.5	2.0	100	15	70	5.0	25
1N6515LL	3000	2.5	1.5	1.0	25	6.0	1.5	60	10	70	5.0	20
1N6517LL	5000	1.5	1.0	1.0	25	8.0	1.0	40	8	70	5.0	16

(1)TC=55°C (2)TC=100°C (3)I_f=0.5A, I_r=1.0A, I_{rr}=0.25A *Op. Temp.= -65°C to +175°C Stg. Temp.= -65°C to +200°C

6

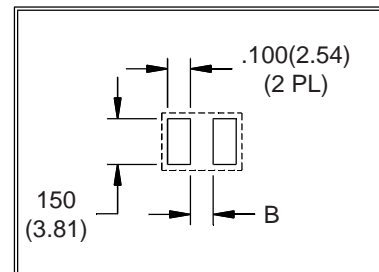
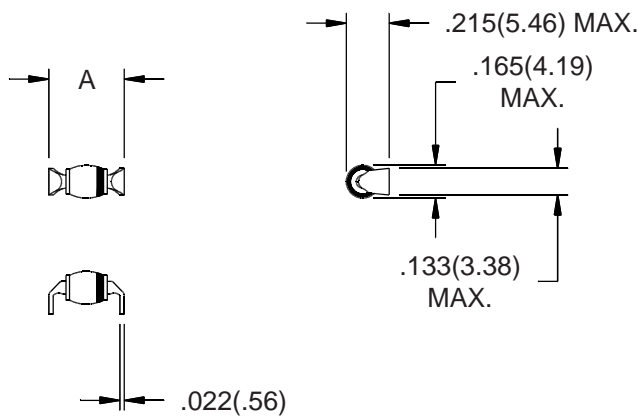

Part	A	B
1N6513LL	.345(8.76) MAX. .315(8.00) MIN.	.210 (5.33)
1N6515LL	.365(9.27) MAX. .335(8.51) MIN.	.230 (5.84)
1N6517LL	.380(9.65) MAX. .350(8.89) MIN.	.250 (6.35)



Dimensions: In. (mm) • All temperatures are ambient unless otherwise noted. • Data subject to change without notice.



VOLTAGE MULTIPLIERS INC.
 8711 W. Roosevelt Ave.
 Visalia, CA 93291

TEL 559-651-1402
 FAX 559-651-0740
 www.voltagemultipliers.com

1N6513LL 1N6515LL 1N6517LL

