

## Advanced Software Radio™ MIMO SDR / Motion Sensing Module

Loctronix Advanced Software Radio™ (ASR) waveform and hardware solutions enable high-performance navigation for GNSS challenged environments. The ASR-2300 is Loctronix's multiple-input, multiple-output (MIMO) software defined radio (SDR) combining two broadband RF transceivers, a high performance DSP FPGA, and three dimensional motion-sensing capabilities. Ideal for signals of opportunity (SoOp) and multi-sensor applications, the module provides the core sensors and RF signal processing functions in a low size, weight, and power form-factor.



ASR-2300

Two RF transceiver chips provide multiple bands of transmit and receive functionality for simultaneous reception and transmission. On-board integrated filters and antennas are provided for reception of PCS, ISM, and L1 GPS bands. Wideband U.FL connectors are available to enable reception and transmission in the region between 300 MHz to 3.8 GHz with up to 28 MHz of bandwidth at 12 bit I/Q sampling. High resolution three dimensional MEMS accelerometer, gyroscopes, compass, and barometer provide real-time motion sensing information with configurable update rates.

The ASR-2300 designs and driver source code are freely available at the A2300 Open Source Project visit [myriadRF.org](http://myriadRF.org) for details.



## Features

- ◆ Four channels simultaneous transmit and receive at max. 28 MHz bandwidth supporting half and full-duplex operation (*transmit functions disabled in factory firmware and logic*)
- ◆ Two Lime Microsystems FPRF transceivers programmable between 300 MHz to 3.8 GHz with 12 bit I/Q sampling and 9 built-in RF Paths.
- ◆ Integrated MEMS accelerometer / gyroscope / compass / barometer / temperature
- ◆ Specialized PCS / UMTS / GPS / ISM / UHF bands RF inputs and outputs (as FCC permitted)
- ◆ On-board GPS C/A and ISM Band antennas
- ◆ Maximum Data Transfer of 315 MB/s
- ◆ Extra-large programmable Xilinx Spartan 6 FPGA
- ◆ Expansion port for MIMO and other I/O
- ◆ Built-in 128 MiB DDR RAM
- ◆ Low speed 600 kbps UART
- ◆ Power: 5 Volts (USB) @ 0.68 A, 3.4 W maximum required power (90% utilization).
- ◆ Mobile operations capability with Li-Ion battery power

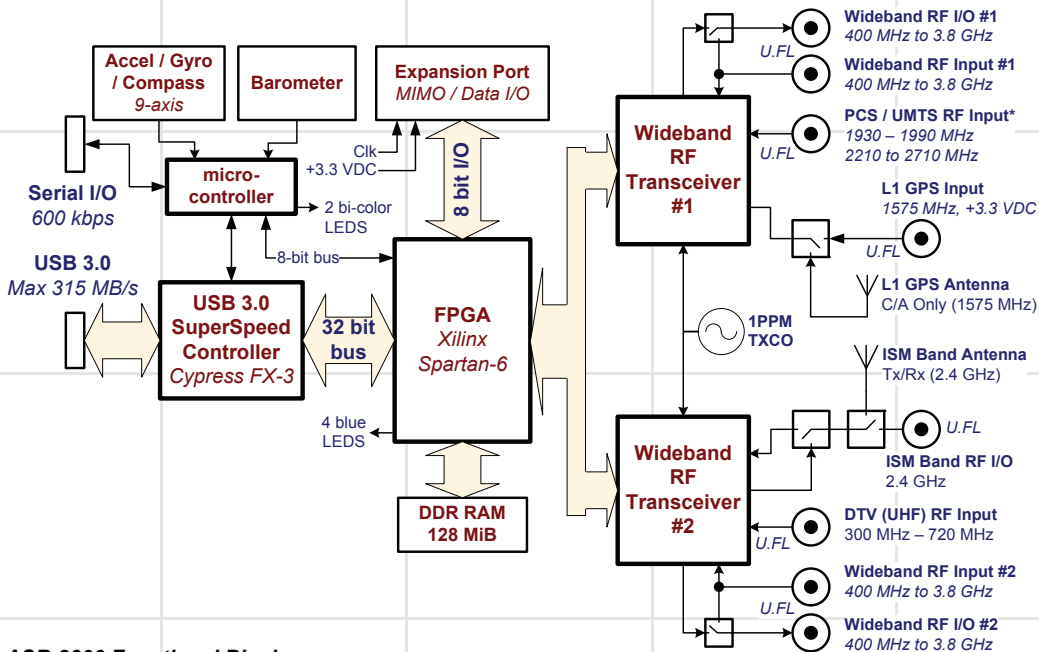

### ASR-2300 Functional Blocks

\*PCS is standard, UMTS or other bands available by special order.

### RF Specifications

The ASR-2300 has two wideband direct up/down conversion transceivers with two multi-band and four dedicated RF band input / outputs (I/O).

- ◆ Two wideband (400 MHz – 3.8 GHz) transmit and receive paths with selectable separate or combined RF I/O.
- ◆ Dedicated PCS (1930-1990 MHz) receive path. UMTS (2210 to 2710 MHz) or other bands available with special order.
- ◆ Dedicated L1 GPS band receive path, 1575 MHz with selectable external input or on-board antenna; selectable 3.3V power for active antennas.
- ◆ Dedicated 2.4 GHz ISM band transmit/receive path with selectable external I/O or on board antenna.
- ◆ Dedicated 300 MHz to 650 MHz UHF band receive path for DTV
- ◆ 1 ppm coherent common clock reference for digital sampling and up/down frequency conversion.
- ◆ Transmit functions disabled with factory default firmware

### Electrical Interface

- ◆ SuperSpeed USB 3, or USB 2.0 data and power. Max data rates: 315 MB/s or 35 MB/s respectively.
- ◆ 600 kbps UART 4 pin header type connector.
- ◆ 3.6 Volt Li-Ion Battery connection
- ◆ 8 U.FL RF input and outputs include general purpose and dedicated receive/transmit paths.
- ◆ 10 pin Expansion Port providing 3.3V; ground; and 8 bits, programmable GPIO.
- ◆ Built-in L1 C/A GPS and ISM Band antennas

### Physical Specifications

- ◆ Size: 10.00 cm × 6.62 cm × 1.40 cm (3.937 in × 2.61 in × 0.551 in)  
Height with LED stand and power switch removed: 0.7cm (0.276 in.)
- ◆ Weight: approx. 48 gram ( 1.5 oz.)

### Wideband RF Transceivers

- ◆ Two, single chip, multiband full duplex transceiver covering 300 MHz to 3.8 GHz
- ◆ Integrated 12 bit I/Q D/A, A/D converters, selectable bandwidths between 1.5 and 28 MHz

### 9-axis MEMS Accelerometer / Gyro / Compass

- ◆ 3-axis gyroscope ranges of ±250, ±500, ±1000, and ±2000°/sec
- ◆ 3-axis accelerometer ranges of ±2g, ±4g, ±8g and ±16g
- ◆ 3-axis magnetometer resolution 0.3 μT typical, ±1200 μT maximum range
- ◆ Accelerometer / Gyroscope maximum sample rate: 1.024 / 8.192 kHz
- ◆ Integrated motion processing engine, recognizes gestures and provides wake-up interrupts

### Barometer

- ◆ Altitude resolution: better than 30 cm,
- ◆ Pressure resolution: 1.5 Pa
- ◆ Pressure range 20-110 kPa

### FPGA

- ◆ Slices: 6,822
- ◆ Multiply/DSP Slices: 58
- ◆ RAM: 2088 kbits (261 kBytes on board), 128 MiB external
- ◆ Programmable clocks up to 360 MHz
- ◆ Xilinx XC6SLX45 is standard, larger available by special order.

### Loctronix Kits and Development Tools

- ◆ **ASR-2300 Module** – OEM module for embedded applications
- ◆ **Housing Kit** – Configurable Housing Kit for the ASR-2300.
- ◆ **ASR Workbench** – Easy to use Windows base GUI for modeling SDR signal processing.

### ASR-2300 Supported SDR Waveforms\*\*

- ◆ **IDS** – GNSS Interference Detection System
- ◆ **HGX** – Hybrid GPS Receiver, L1/L2 high-performance navigation
- ◆ **DAIN** – Doppler Aided Inertial Navigation with Signals of Opportunity

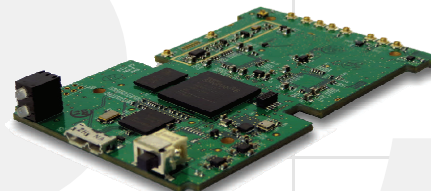

ASR-2300 Module

\*\* Contact Loctronix for details.

For more information contact:

[www.loctronix.com](http://www.loctronix.com)

+1.425.307.3485

Loctronix Corporation  
18815 139th Ave. NE, Suite A-1  
Woodinville, WA 98072  
United States of America

**Loctronix**<sup>™</sup>  
Locked on Location

© 2014 Loctronix Corporation, All Rights Reserved