

# RA CONNECTOR<IDC>

Disconnectable Insulation displacement connectors for 1.27mm pitch ribbon cables

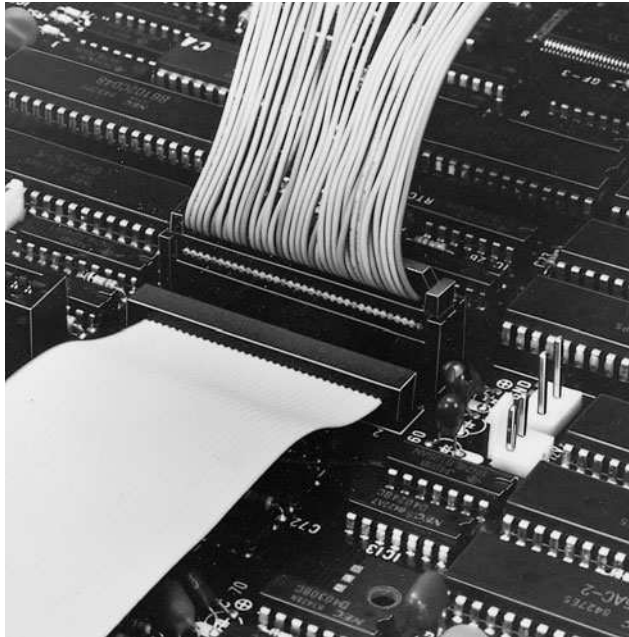

*To keep pace with the rapid developments in electronics, internal and external connection systems are naturally increasing in density. At the same time, labor requirements and overall costs must be minimized. RA connectors meet all of these requirements, while providing increased reliability. These connectors, whose materials, shapes, dimensions, and surface treatments have been carefully selected, are based on the latest technological information that has been accumulated and improved over years of experience in crimping connection technology.*

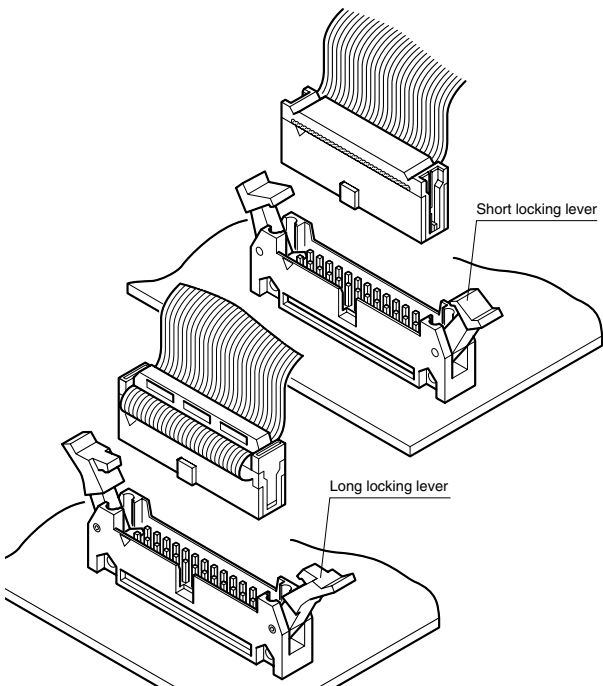

## Features

### • Twin U-slot ID section

The twin U-slot is the most important IDC element in JST's RA connectors. As shown in the figure, wire conductors are connected between the slots of U-shaped parallel beams, and the distance between each adjacent pair of beams is designed to be one third of the pitch of wire strands.

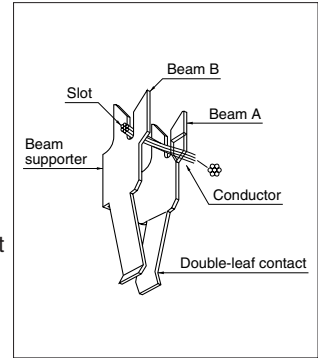

### • Two-die processing and selective gold plating

Two precision dies are used to blank and form the contacts. After the first die blanks the contacts, they are gold plated at crucial points. Then, the contacts are formed by the second die. This eliminates unnecessary gold-plating and overall costs are minimized. This innovation is another example of our industry-leading technology.

### • Selective gold-plated posts

Header posts are also selectively gold-plated. While square wire material is used for production of conventional posts in loose pieces, continuous flat strip is used for production of our post in chain form. This allows selective gold-plating and provides cost reduction.

### • Cost-efficient

JST's unique technology allows it to produce connectors that are extremely reliable and cost-efficient.

### • Interchangeable cables and connectors

RA connectors fit commercially available 1.27mm pitch flat ribbon cables. A variety of ribbon cables are offered according to the purpose. Moreover, the RA series receptacles and header are interchangeable with the similar type of connectors commercially available. Contact JST before procuring cables and other manufacturer's mating connectors.

\* Compliant with RoHS.

\* Refer to "General Instruction and Notice when using Terminals and Connectors" at the end of this catalog.

\* Contact JST for details.

## Standards

Recognized E60389

Certified LR20812

## Receptacle

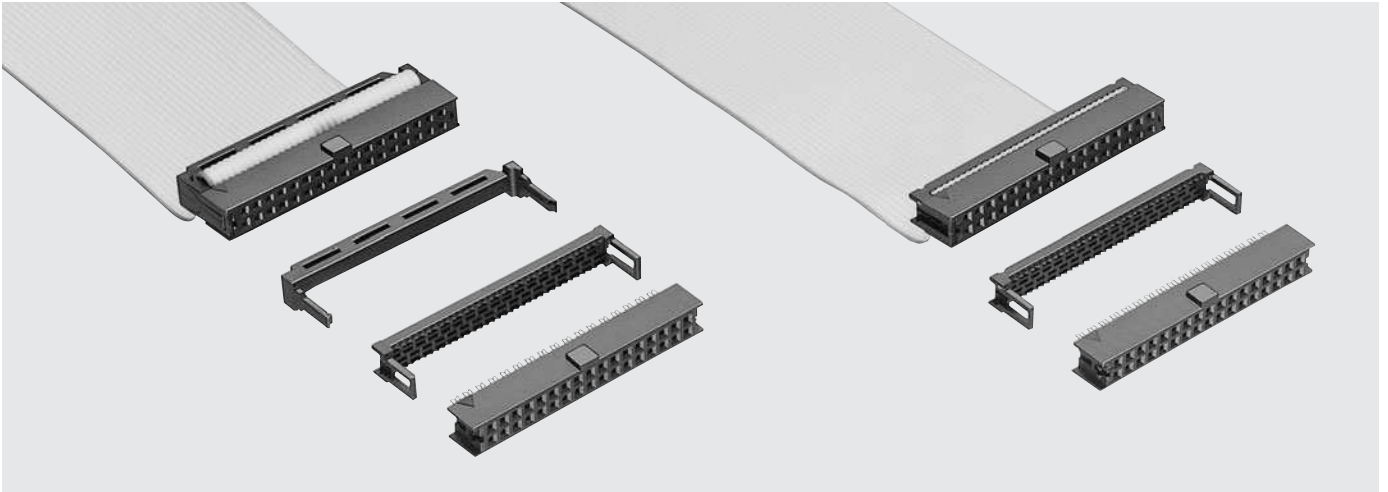

## Specifications

### Characteristics

Current rating	1.0A AC, DC
Voltage rating	300V AC, DC
Temperature range	(including temperature rise in applying electrical current) -55°C to +125°C (gold-plated) -55°C to +105°C (tin-plated)
Contact resistance	Initial value/10mΩ max. (gold-plated) 40mΩ max. (tin-plated) After environmental testing/ 15mΩ max. (gold-plated) 50mΩ max. (tin-plated)
Insulation resistance	5,000MΩ min.
Withstanding voltage	500V AC/5 seconds
Applicable wire	AWG #28, 1.27mm pitch ribbon cable

### Materials

Contact	Phosphor bronze • Nickel-undercoated, selective gold-plated • Copper-undercoated, tin-plated (reflow treatment)
Receptacle housing	Glass-filled PBT, UL94V-0, black
Cover housing	Glass-filled PBT, UL94V-0, black
Strain relief	Glass-filled PBT, UL94V-0, black

\*Contact JST for details.

## Applicable cables

Ribbon cables conforming to the following specifications can be used with RA connector receptacles. Contact JST for details.

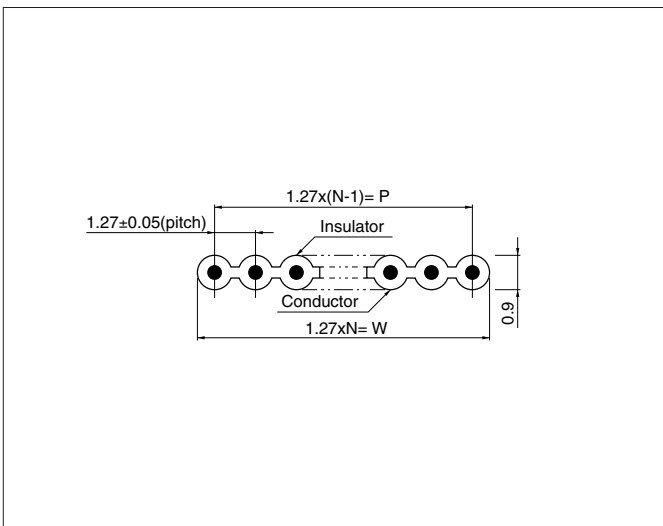

Note: N --- Number of circuits

No. of conductors (n)	Dimensional tolerance (mm)	
	P	W
10 to 14	±0.18	±0.3
16 to 26	±0.28	±0.3
34 to 60	±0.38	±0.3

Conductor	AWG #28 stranded wire Construction: 7/0.127mm dia. Material: Tin-plated annealed copper wire
	AWG #28 solid wire Construction: 0.32mm dia. Material: Tin-plated annealed copper wire
Insulator	Soft vinyl chloride

# RA CONNECTOR

## Model number identification

• Series name	RA — S 50 1 T — 1 2 00	
• Product name: Receptacle		
• Number of circuits: 10, 14, 16, 20, 26, 34, 40, 50, 60		
• Number of guide ribs: 10 to 40 circuits ... 1 50 circuits ... 0, 1, 2 60 circuits ... 1, 2		
• Connection method: T ... Through type S ... Short lock through type		
• With or without strain relief 0 ... Without 1 ... With		
• Contact material: 2 ... Phosphor bronze for spring		
• Surface finish	00... Gold-plated (flash)	02... 0.2micron gold-plated
	03... 0.4micron gold-plated	04... 0.76micron gold-plated
	90... Tin-plated (reflow treatment)	

Note:

The standard gold-plated type is identified by the suffix number [-1200], but this suffix number is usually omitted. The gold-plated type identified by [-0200] is indicated by [-0] for short. Other types must be identified by the full code number. Special types do not conform to the above coding system.

### Receptacle for long locking lever header

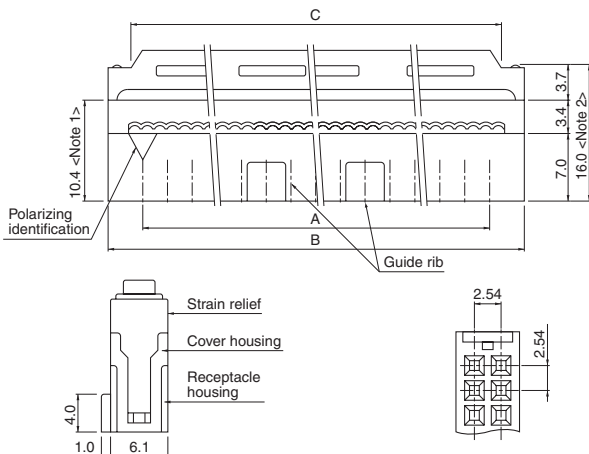

<Note 1>: Height without strain relief <Note 2>: Height with strain relief

### Receptacle for short locking lever header

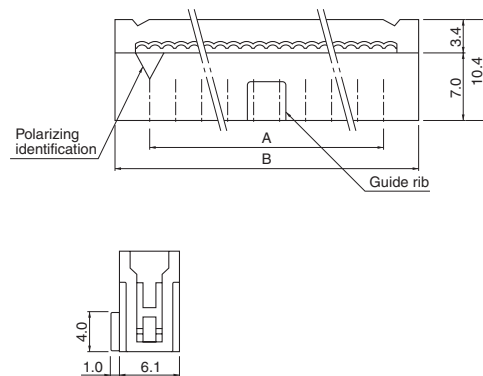

Circuits	Type of cover housing	No. of guide ribs	Model No.			Dimensions (mm)			Qty / box
			Gold-plated receptacles		Tin-plated receptacles (With strain relief)	A	B	C	
			With strain relief	Without strain relief					
10	Long type	1	RA-S101T	RA-S101T-0	RA-S101T-1290	10.16	17.30	13.00	300
14		1	RA-S141T	RA-S141T-0	RA-S141T-1290	15.24	22.38	18.08	200
16		1	RA-S161T	RA-S161T-0	RA-S161T-1290	17.78	24.92	20.62	200
20		1	RA-S201T	RA-S201T-0	RA-S201T-1290	22.86	30.00	25.70	150
26	Short type	1	RA-S261T	RA-S261T-0	RA-S261T-1290	30.48	37.62	33.32	150
34		1	—	RA-S341S-0	—	40.64	47.78	—	100
40	Long type	1	RA-S341T	RA-S341T-0	RA-S341T-1290	48.26	55.40	43.48	100
40	Short type	1	RA-S401T	RA-S401T-0	RA-S401T-1290	48.26	55.40	51.10	100
50	Long type	1	—	RA-S502S-0	—	60.96	68.10	—	75
		0	RA-S500T	RA-S500T-0	RA-S500T-1290			63.80	
		1	RA-S501T	RA-S501T-0	RA-S501T-1290				
2	RA-S502T	RA-S502T-0	RA-S502T-1290						
60	Short type	1	—	RA-S602S-0	—	73.66	80.80	—	75
	Long type	1	RA-S601T	RA-S601T-0	RA-S601T-1290			76.50	
		2	RA-S602T	RA-S602T-0	RA-S602T-1290				

RoHS compliance Tin-plated products display (LF)(SN) on a label.

## Strain relief and cover housing

Indicate the Model No. shown below when ordering strain relief and cover separately.

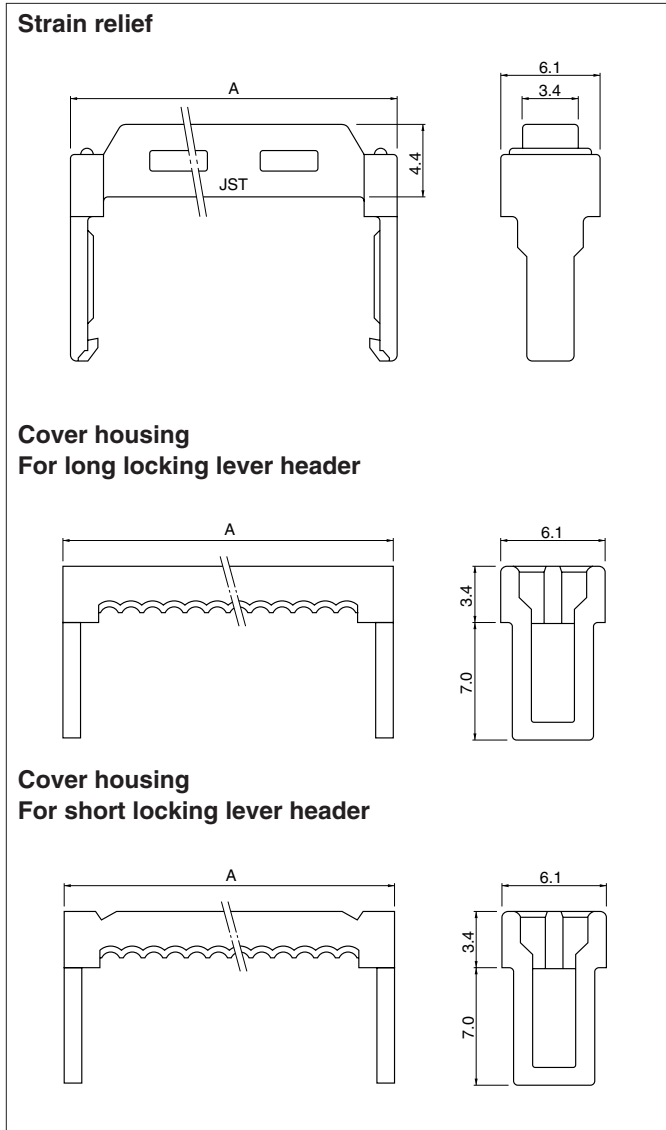

Cir- cuits	Model No.			Dimensions (mm)
	Strain relief	Cover housing		A
		Long type	Short type	
10	RA-SR10T-1	RA-CH10T	—	17.30
14	RA-SR14T-1	RA-CH14T	—	22.38
16	RA-SR16T-1	RA-CH16T	—	24.92
20	RA-SR20T-3	RA-CH20T	—	30.00
26	RA-SR26T-3	RA-CH26T	—	37.62
34	RA-SR34T-3	RA-CH34T	RA-CH34S	47.78
40	RA-SR40T-3	RA-CH40T	—	55.40
50	RA-SR50T-3	RA-CH50T	RA-CH50S	68.10
60	RA-SR60T-1	RA-CH60T	RA-CH60S	80.80

### RoHS compliance

Note: 1. Color: Black

2. When ordering Strain relief or Cover housing only, refer to the above Model Nos.

# RA CONNECTOR

## Shrouded header

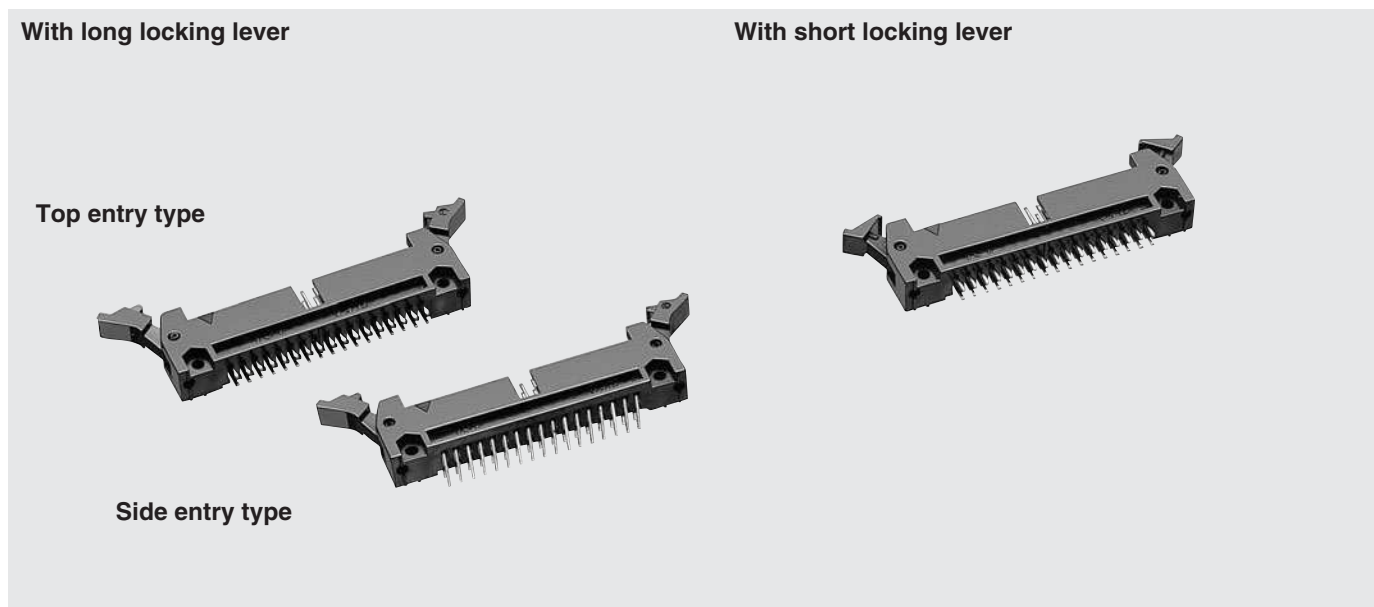

## Specifications

### Characteristics

Current rating	1.0A AC, DC
Voltage rating	300V AC, DC
Temperature range	(including temperature rise in applying electrical current) -55°C to +125°C (gold-plated) -55°C to +105°C (tin-plated)
Insulation resistance	5,000M $\Omega$ min.
Withstanding voltage	500V AC/5 seconds
Applicable PC board thickness	1.6mm

Note: Contact JST for details.

### Materials and Finish

Post	Brass • Nickel-undercoated Mating part; gold-plated Solder tail; tin-plated (reflow treatment) • Copper-undercoated, tin-plated (reflow treatment)
Housing	Glass-filled PBT, UL94V-0, black

## Model number identification

• Series name	RA	H	50	1	TD	1	1	10
• Product name: Header								
• Number of circuits: 10, 14, 16, 20, 26, 34, 40, 50, 60								
• Number of guide grooves: 10 to 40 circuits...1 50 and 60 circuits...1, 2								
• PC board mounting method TD...Top entry SD...Side entry								
• Type of locking lever: 0...Without locking lever 1...Long locking lever 2...Short locking lever								
• Post material: 1...Brass								
• Surface finish: 10...Gold-plated (flash) 12...0.2micron gold-plated 13...0.4micron gold-plated 14...0.76micron gold-plated 90...Tin-plated (reflow treatment)								

Note:

The standard gold-plated type is identified by the suffix number [-1110], but this suffix number is usually omitted. Other types must be identified by the full code number. Special types do not conform to the coding system in the left.

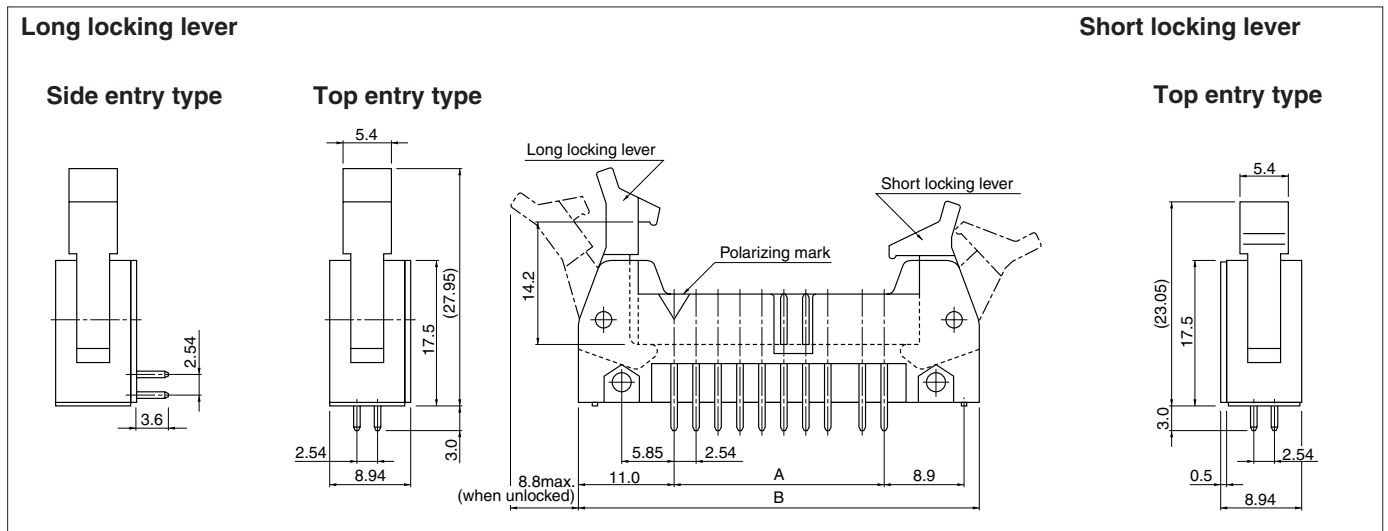

Cir- cuits	Type of locking lever	No.of guide grooves	Model No.				Dimensions (mm)		Q'ty / box
			Gold-plated header (With locking lever)		Tin-plated header (With locking lever)		A	B	
			Top entry type	Side entry type	Top entry type	Side entry type			
10	Long type	1	RA-H101TD	RA-H101SD	RA-H101TD-1190	RA-H101SD-1190	10.16	32.16	50
14		1	RA-H141TD	RA-H141SD	RA-H141TD-1190	RA-H141SD-1190	15.24	37.26	50
16		1	RA-H161TD	RA-H161SD	RA-H161TD-1190	RA-H161SD-1190	17.78	39.78	50
20		1	RA-H201TD	RA-H201SD	RA-H201TD-1190	RA-H201SD-1190	22.86	44.86	50
26		1	RA-H261TD	RA-H261SD	RA-H261TD-1190	RA-H261SD-1190	30.48	52.48	25
34	Short type	1	*RA-H341TD-2110	—	—	—	40.64	62.64	25
	Long type		RA-H341TD	RA-H341SD	RA-H341TD-1190	RA-H341SD-1190			
40	Short type	1	*RA-H401TD-2110	—	—	—	48.26	70.26	25
	Long type		RA-H401TD	RA-H401SD	RA-H401TD-1190	RA-H401SD-1190			
50	Short type	1	*RA-H501TD-2110	—	—	—	60.96	82.96	25
	Long type		*RA-H501TD	*RA-H501SD	*RA-H501TD-1190	*RA-H501SD-1190			
	Long type	2	RA-H502TD	RA-H502SD	RA-H502TD-1190	RA-H502SD-1190			
60	Short type	1	*RA-H601TD-2110	—	—	—	73.66	95.66	25
	Long type		*RA-H601TD	*RA-H601SD	*RA-H601TD-1190	*RA-H601SD-1190			
			2	RA-H602TD	RA-H602SD	RA-H602TD-1190			

**RoHS compliance** This product displays (LF)(SN) on a label.

Note: 1.Headers with locking levers can be used only for receptacle with strain reliefs.

2.\*Marked products are not CSA approved.

# RA CONNECTOR

## PC board layout (viewed from component side)

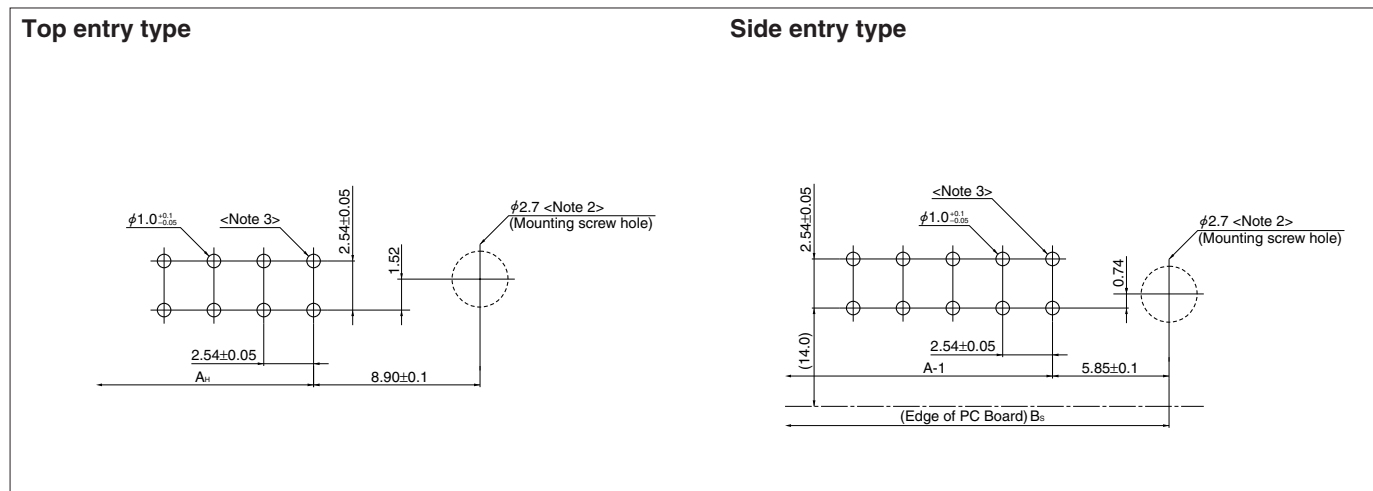

Cir- cuits	Dimensions (mm)	
	$A_H$	$B_S$
10	10.16	21.86
14	15.24	26.94
16	17.78	29.48
20	22.86	34.56
26	30.48	42.18
34	40.64	52.34
40	48.26	59.96
50	60.96	72.66
60	73.66	85.36

### Note:

1. Tolerances are non-cumulative:  $\pm 0.05$ mm for all centers.  
Hole dimensions differ according to the kind of PC board and piercing method. The dimensions above should serve as a guideline.  
Contact JST for details.
2. The mounting screw holes are not required for standard headers.
3. This is normally No. 1 pin position.