

General Description

The AOZ1213 is a high efficiency, simple to use, buck regulator plus one linear regulator controller optimized for a variety of applications.

The AOZ1213 works from a 4.5V to 28V wide input voltage range. The buck regulator provides up to 3A of continuous output current. Each output voltage is adjustable down to 0.8V.

The AOZ1213 is available in a 4x3 DFN-12 package and can operate over a -40°C to +85°C ambient temperature range.

Features

- 4.5V to 28V operating input voltage range
- Integrated linear regulator controller
- 70mΩ internal NFET, efficiency: up to 95%
- Internal soft start
- Each output voltage adjustable down to 0.8V
- 3A continuous output current
- Fixed 370kHz PWM operation
- Cycle-by-cycle current limit
- Short-circuit protection
- Thermal shutdown
- Small size 4x3 DFN-12 packages

Applications

- Point of load DC/DC conversion
- Set top boxes
- LCD Monitors & TVs
- Cable modems
- Telecom/Networking/Datacom equipment



Typical Application

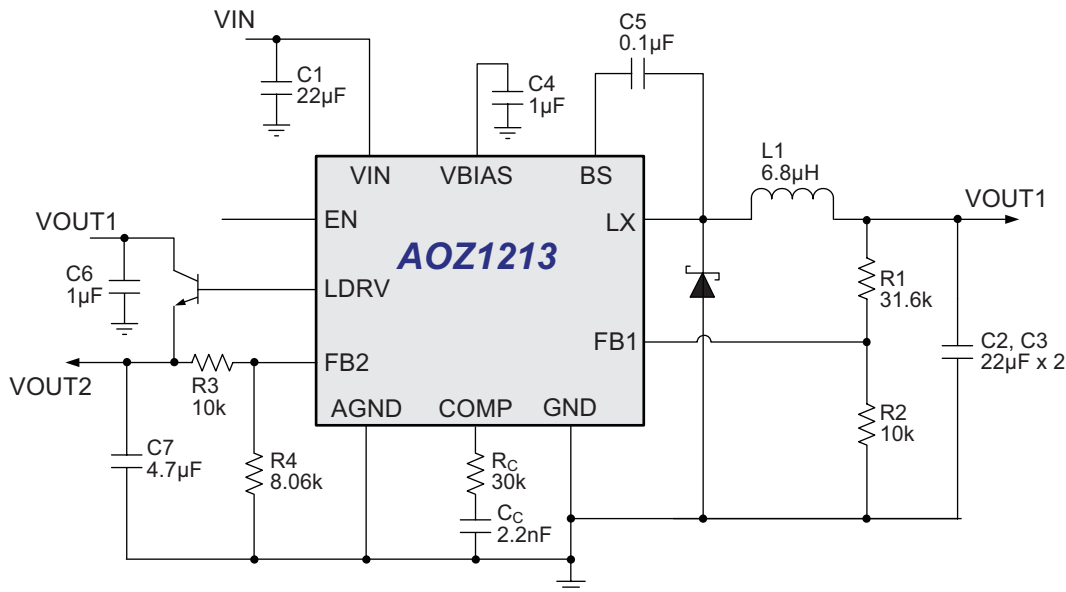

Figure 1. Typical Application Circuit

Ordering Information

| Part Number | Ambient Temperature Range | Package | Environmental |
|-------------|---------------------------|------------|---------------------------------|
| AOZ1213DI | -40°C to +85°C | 4x3 DFN-12 | RoHS Compliant Green Product |



AOS Green Products use reduced levels of Halogens, and are also RoHS compliant.

Please visit www.aosmd.com/web/quality/rohs_compliant.jsp for additional information.

Pin Configuration

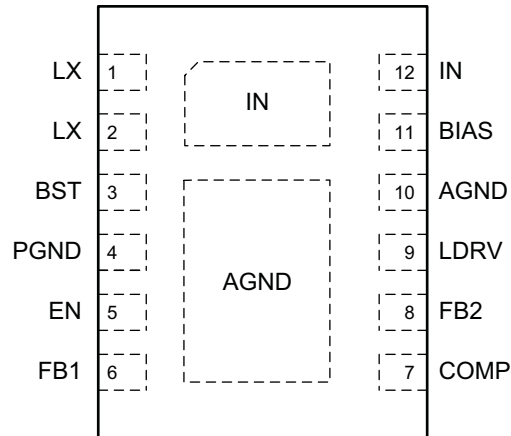

DFN-12
(Top View)

Pin Description

| Pin Number | Pin Name | Pin Function |
|------------|----------|---|
| 1, 2 | LX | Buck Regulator Switching Node. |
| 3 | BST | Buck Regulator Bootstrap Pin. BST is the high side driver supply. Connect a 0.1µF capacitor between BST and LX to form a bootstrap circuit. |
| 4 | PGND | Power Ground. |
| 5 | EN | Enable Input. EN is active high. Connect EN to IN if not used. Do not leave EN floating. |
| 6 | FB1 | Buck Regulator Feedback Input. FB1 is regulated to 0.8V. Set the buck regulator output voltage using a resistive voltage divider. |
| 7 | COMP | Buck Regulator Compensation Pin. COMP is the output of the internal transconductance error amplifier. Connect a RC network between COMP and GND to compensate the control loop. |
| 8 | FB2 | Linear Regulator Feedback Input. FB2 is regulated to 0.8V. Set the linear regulator output voltage using a resistive voltage divider. |
| 9 | LDRV | Linear Regulator Drive Output. LDRV controls the gate of an external pass transistor. |
| 10 | AGND | Analog Ground. |
| 11 | BIAS | Internal Bias Regulator Output. Connect a 1µF between BIAS and GND. |
| 12 | IN | Input Supply Pin. The input range is between 4.5V and 28V. |

Electrical Characteristics

$T_A = 25^\circ\text{C}$, $V_{IN} = V_{EN} = 12\text{V}$, unless otherwise specified⁽³⁾

| Symbol | Parameter | Conditions | Min. | Typ. | Max. | Units |
|--------------------------|---------------------------------------|--|------------|------------|------------|--------------------------|
| V_{IN} | Supply Voltage | | 4.5 | | 28 | V |
| V_{UVLO} | Input Under-Voltage Lockout Threshold | V_{IN} Rising | | 4.0 | | V |
| | | V_{IN} Falling | | 3.7 | | V |
| I_{IN} | Supply Current (Quiescent) | $I_{OUT} = 0$, $V_{FB} = 1.2\text{V}$, $V_{EN} > 2\text{V}$ | | 2 | 3 | mA |
| I_{OFF} | Shutdown Supply Current | $V_{EN} = 0\text{V}$ | | 3 | 20 | μA |
| $V_{FB1, 2}$ | Feedback Voltage | | 0.788 | 0.8 | 0.812 | V |
| | Load Regulation | | | 0.5 | | % |
| | Line Regulation | | | 0.1 | | % |
| I_{FB1} | Feedback Voltage Input Current | | | | 200 | nA |
| ENABLE | | | | | | |
| V_{EN} | EN Input Threshold | Off Threshold | | | 0.6 | V |
| | | On Threshold | 2.5 | | | V |
| V_{HYS} | EN input Hysteresis | | | 200 | | mV |
| I_{EN} | Enable Sink/Source current | | | | 50 | nA |
| MODULATOR | | | | | | |
| f_O | Frequency | | 315 | 370 | 425 | kHz |
| D_{MAX} | Maximum Duty Cycle | | | 85 | | % |
| D_{MIN} | Minimum Duty Cycle | | | 5 | | % |
| G_{VEA} | Error Amplifier Voltage Gain | | | 500 | | V / V |
| G_{EA} | Error Amplifier Transconductance | | | 200 | | $\mu\text{A} / \text{V}$ |
| PROTECTION | | | | | | |
| I_{LIM} | Current Limit | | 4 | 4.5 | 5 | A |
| | Over-Temperature Shutdown Limit | T_J Rising | | 145 | | $^\circ\text{C}$ |
| | | T_J Falling | | 100 | | $^\circ\text{C}$ |
| t_{SS} | Soft Start Interval | | | 6 | | ms |
| PWM OUTPUT STAGE | | | | | | |
| $R_{DS(ON)}$ | High-Side Switch On-Resistance | | | 70 | 100 | $\text{m}\Omega$ |
| | High-Side Switch Leakage | $V_{EN} = 0\text{V}$, $V_{LX} = 0\text{V}$ | | | 10 | μA |
| LINEAR CONTROLLER | | | | | | |
| LDRV Vout | Drive Output High Voltage | $V_{fb2} = 0.7\text{V}$, LDRV, $I_{out} = 20\text{mA}$, $I_{out1} = 0$ | 4 | | | V |
| LDRV Iout | Drive Output Current | $V_{fb2} = 0.7\text{V}$, $I_{out1} = 0$ | 10 | | | mA |
| | Under Voltage Threshold | | | 0.6 | | V |
| | Line Regulation | | | 0.5 | | % |
| | Load Regulation | | | 1 | | % |
| I_{FB2} | FB2 Leakage | | | | 150 | nA |

Note:

3. Specification in **BOLD** indicate an ambient temperature range of -40°C to $+85^\circ\text{C}$. These specifications are guaranteed by design.

Typical Performance Characteristics

Circuit of Figure 1. $T_A = 25^\circ\text{C}$, $V_{IN} = V_{EN} = 12\text{V}$, $V_{OUT} = 3.3\text{V}$ unless otherwise specified.

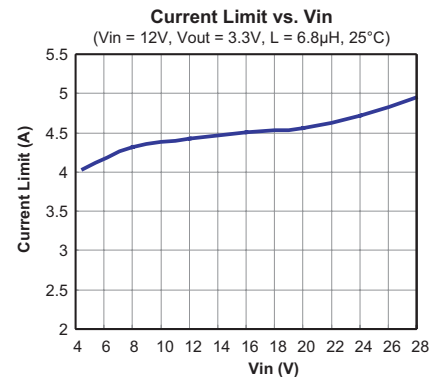
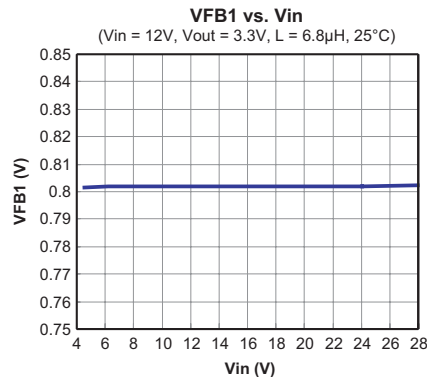
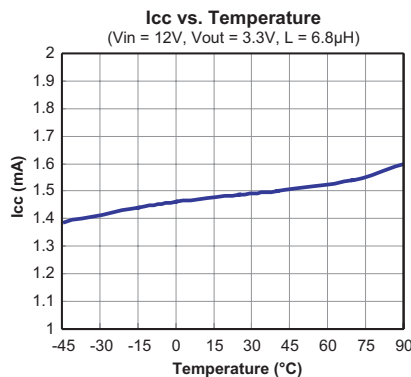
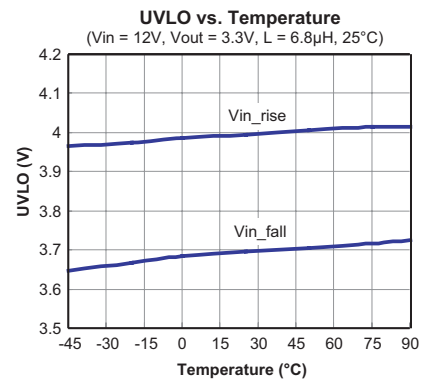
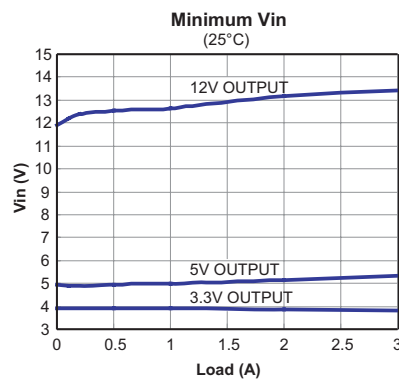
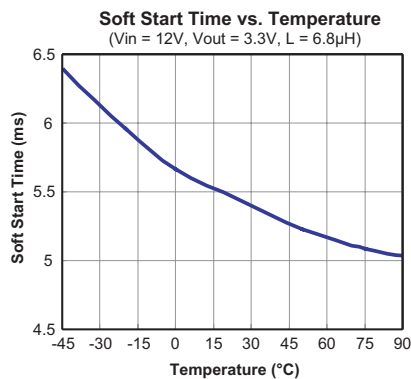
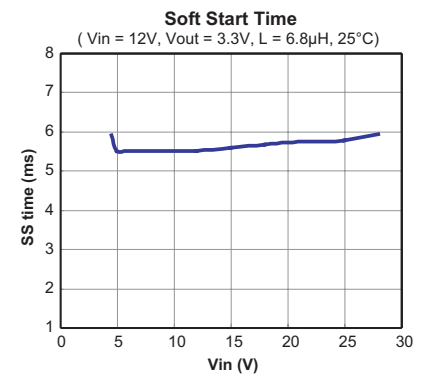
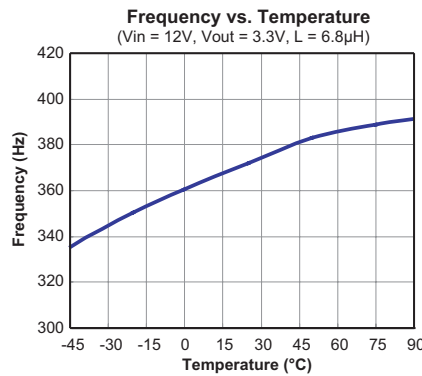
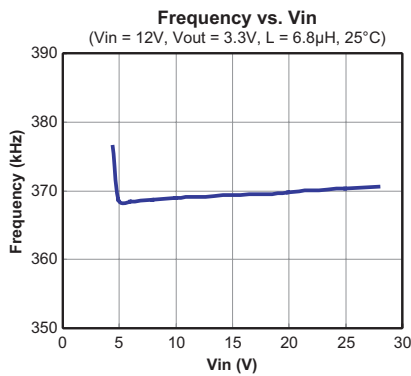
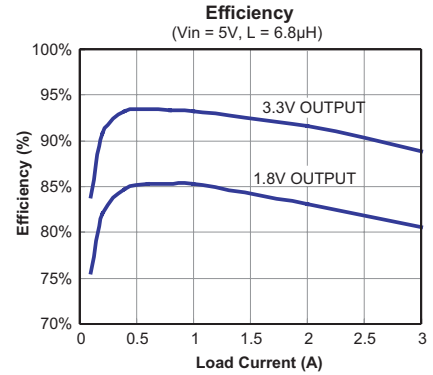
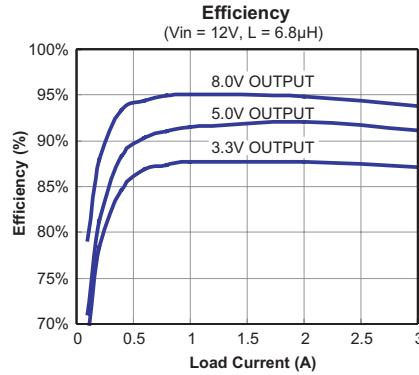
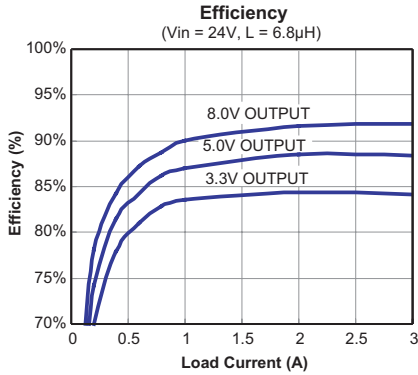

Typical Performance Characteristics (Continued)

Circuit of Figure 1. $T_A = 25^\circ\text{C}$, $V_{IN} = V_{EN} = 12\text{V}$, $V_{OUT} = 3.3\text{V}$ unless otherwise specified.

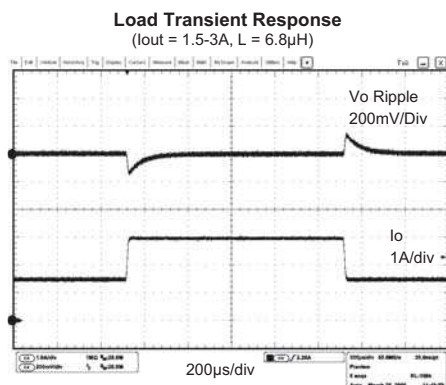
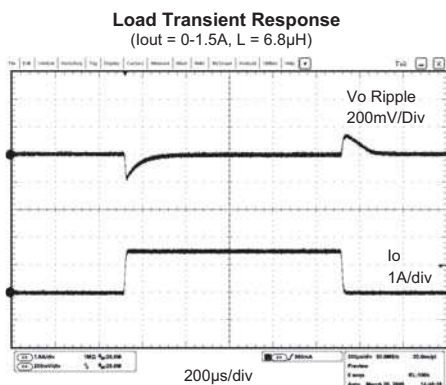
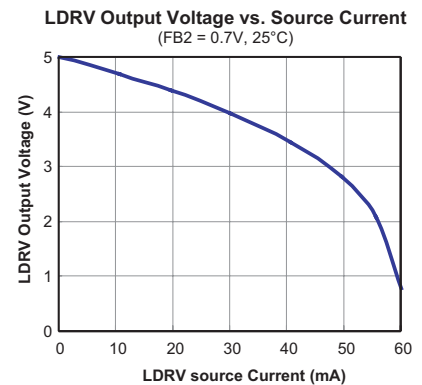
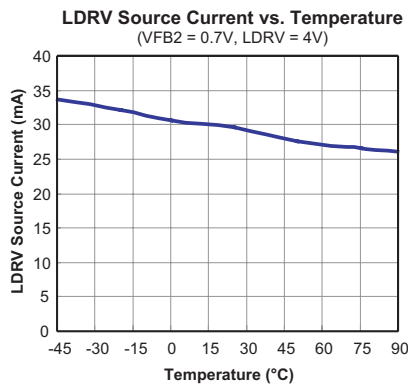
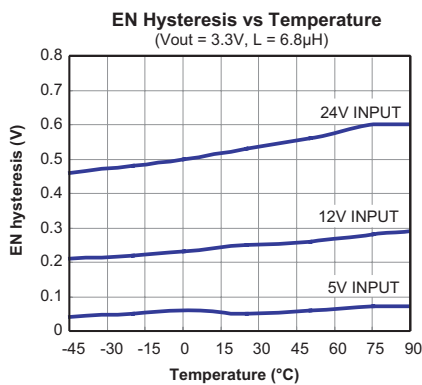
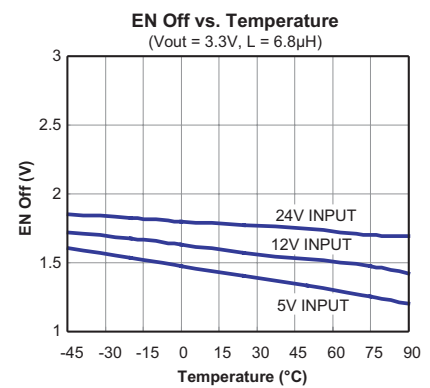
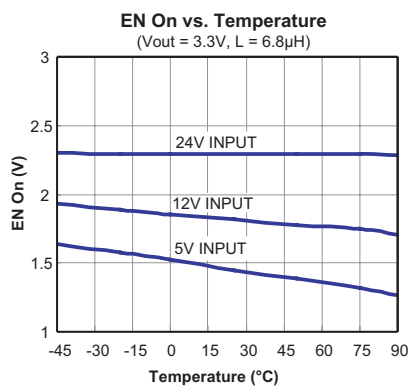
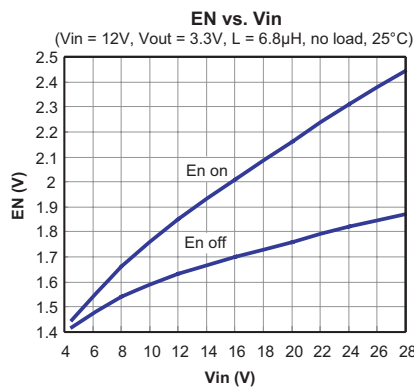
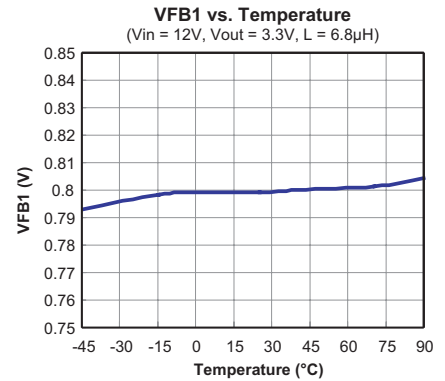
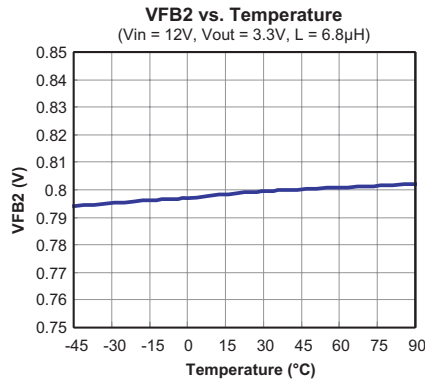
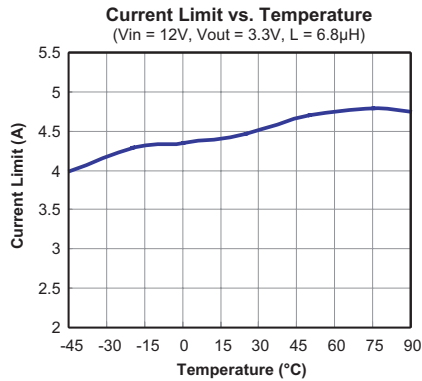

Detailed Description

The AOZ1213 is a current-mode step down regulator with integrated high side NMOS switch. It operates from a 4.5V to 28V input voltage range and supplies up to 3A of load current. The duty cycle can be adjusted from 5% to 85% allowing a wide range of output voltage. Features include enable control, Power-On Reset, input under voltage lockout, fixed internal soft-start and thermal shut down. The linear regulator controller is designed to drive an external NPN power transistor or an N channel power MOSFET to provide up to 1A of current to an auxiliary load.

The AOZ1213 is available in 4X3 DFN-12 package.

Enable and Soft Start

The AOZ1213 has internal soft start feature to limit in-rush current and ensure the output voltage ramps up smoothly to regulation voltage. A soft start process begins when the input voltage rises to 4.0V and voltage on EN pin is HIGH. In soft start process, the output voltage is ramped to regulation voltage in typically 6ms. The 6ms soft start time is set internally.

Connect the EN pin to VIN if the enable function is not used. Pulling EN to ground will disable the AOZ1213. Do not leave it open. The voltage on EN pin must be above 2.5 V to enable the AOZ1213. When voltage on EN pin falls below 0.6V, the AOZ1213 is disabled. If an application circuit requires the AOZ1213 to be disabled, an open drain or open collector circuit should be used to interface to the EN pin.

Steady-State Operation

Under steady-state conditions, the converter operates in fixed frequency and Continuous-Conduction Mode (CCM).

The AOZ1213 integrates an internal N-MOSFET as the high-side switch. Inductor current is sensed by amplifying the voltage drop across the drain to the source of the high side power MOSFET. Since the N-MOSFET requires a gate voltage higher than the input voltage, a boost capacitor connected between LX pin and BST pin drives the gate. The boost capacitor is charged while LX is low. An internal 10³/₄ switch from LX to PGND is used to ensure that LX is pulled to PGND even with a light load. Output voltage is divided down by the external voltage divider at the FB pin. The difference of the FB pin voltage and reference is amplified by the internal

transconductance error amplifier. The error voltage, which shows on the COMP pin, is compared against the current signal, which is the sum of inductor current signal and ramp compensation signal, at PWM comparator input. If the current signal is less than the error voltage, the internal high-side switch is on. The inductor current flows from the input through the inductor to the output. When the current signal exceeds the error voltage, the high-side switch is off. The inductor current is freewheeling through the Schottky diode to output.

Switching Frequency

The AOZ1213 switching frequency is fixed and set by an internal oscillator. The switching frequency is set 370kHz.

Output Voltage Programming

Output voltage can be set by feeding back the output to the FB pin with a resistor divider network. In the application circuit shown in Figure 1. The resistor divider network includes R₁ and R₂. Usually, a design is started by picking a fixed R₂ value and calculating the required R₁ with equation below:

$$V_{OUT1} = 0.8 \times \left(1 + \frac{R_1}{R_2} \right)$$

Some standard values of R₁, R₂ for most commonly used output voltage values are listed in Table 1.

Table 1.

| Vo (V) | R1 (kΩ) | R2 (kΩ) |
|--------|---------|---------|
| 0.8 | 1.0 | Open |
| 1.2 | 4.99 | 10 |
| 1.5 | 10 | 11.5 |
| 1.8 | 12.7 | 10.2 |
| 2.5 | 21.5 | 10 |
| 3.3 | 31.6 | 10 |
| 5.0 | 52.3 | 10 |
| 12.0 | 140 | 10 |

The combination of R₁ and R₂ should be large enough to avoid drawing excessive current from the output, which will cause power loss.

Protection Features

The AOZ1213 has multiple protection features to prevent system circuit damage under abnormal conditions.

Over Current Protection (OCP)

The sensed inductor current signal is also used for over current protection. Since the AOZ1213 employs peak current mode control, the COMP pin voltage is proportional to the peak inductor current. The COMP pin voltage is limited to be between 0.4V and 2.5V internally. The peak inductor current is automatically limited cycle by cycle.

The cycle by cycle current limit threshold is internally set. When the load current reaches the current limit threshold, the cycle by cycle current limit circuit turns off the high side switch immediately to terminate the current duty cycle. The inductor current stop rising. The cycle by cycle current limit protection directly limits inductor peak current. The average inductor current is also limited due to the limitation on peak inductor current. When cycle by cycle current limit circuit is triggered, the output voltage drops as the duty cycle decreasing.

The AOZ1213 has internal short circuit protection to protect itself from catastrophic failure under output short circuit conditions. The FB pin voltage is proportional to the output voltage. Whenever FB pin voltage is below 0.3V, the short circuit protection is triggered. To prevent current limit running away, when comp pin voltage is higher than 2.1V, the short circuit protection is also triggered. When the above conditions happen, PWM turns off immediately, after about 1mS the converter restarts via a soft start scheme. The short circuit protection process repeats until the short circuit condition disappears.

Power-On Reset (POR)

A power-on reset circuit monitors the input voltage. When the input voltage exceeds 4.0V, the converter starts operation. When input voltage falls below 3.7V, the converter will stop switching.

Linear Regulator

The AOZ1213 contains an error amplifier which can be configured as a linear regulator controller. By adding an external follower (NPN or NMOS) and divider resistors as shown in Figure 1, the FB2 and LDRV pins can be configured as a controller for a Low Dropout Regulator.

The LDRV pin source capability come from LDO inside which is capable more than 10mA of base current to the external NPN transistor.

The FB2 voltage is monitored by an Under Voltage Protection circuit, which shutdown LDRV output when FB2 voltage is under 0.6V.

Thermal Protection

An internal temperature sensor monitors the junction temperature. It shuts down the internal control circuit and high side NMOS if the junction temperature exceeds 145°C. The regulator will restart automatically under the control of soft-start circuit when the junction temperature decreases to 100°C.

Application Information

The basic AOZ1213 application circuit is shown in Figure 1. Component selection is explained below.

Buck Regulator Design

Input Capacitor

The input capacitor (C_1 in Figure 1) must be connected to the V_{IN} pin and GND pin of the AOZ1213 to maintain steady input voltage and filter out the pulsing input current. The voltage rating of input capacitor must be greater than maximum input voltage plus ripple voltage.

The input ripple voltage can be approximated by equation below:

$$\Delta V_{IN} = \frac{I_O}{f \times C_{IN}} \times \left(1 - \frac{V_O}{V_{IN}}\right) \times \frac{V_O}{V_{IN}}$$

Since the input current is discontinuous in a buck converter, the current stress on the input capacitor is another concern when selecting the capacitor. For a buck circuit, the RMS value of input capacitor current can be calculated by:

$$I_{CIN_RMS} = I_O \times \sqrt{\frac{V_O}{V_{IN}} \left(1 - \frac{V_O}{V_{IN}}\right)}$$

if let m equal the conversion ratio:

$$\frac{V_O}{V_{IN}} = m$$

The relationship between the input capacitor RMS current and voltage conversion ratio is calculated and shown in Figure 2 on the next page. It can be seen that when V_O is half of V_{IN} , C_{IN} is under the worst current stress. The worst current stress on C_{IN} is $0.5 \times I_O$.

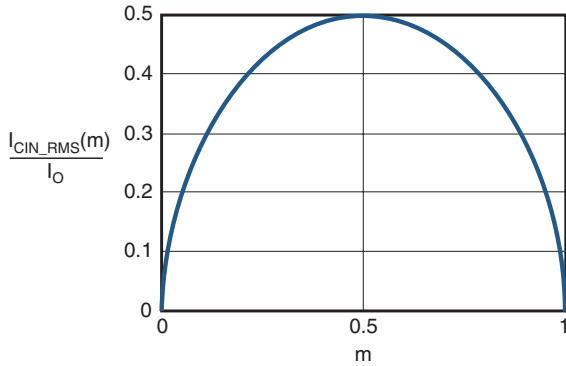

Figure 2. I_{CIN} vs. Voltage Conversion Ratio

For reliable operation and best performance, the input capacitors must have current rating higher than I_{CIN_RMS} at worst operating conditions. Ceramic capacitors are preferred for input capacitors because of their low ESR and high ripple current rating. Depending on the application circuits, other low ESR tantalum capacitor or aluminum electrolytic capacitor may also be used. When selecting ceramic capacitors, X5R or X7R type dielectric ceramic capacitors are preferred for their better temperature and voltage characteristics. Note that the ripple current rating from capacitor manufactures is based on certain amount of life time. Further de-rating may be necessary for practical design requirement.

Inductor

The inductor is used to supply constant current to output when it is driven by a switching voltage. For given input and output voltage, inductance and switching frequency together decide the inductor ripple current, which is,

$$\Delta I_L = \frac{V_O}{f \times L} \times \left(1 - \frac{V_O}{V_{IN}}\right)$$

The peak inductor current is:

$$I_{Lpeak} = I_O + \frac{\Delta I_L}{2}$$

High inductance gives low inductor ripple current but requires larger size inductor to avoid saturation. Low ripple current reduces inductor core losses. It also reduces RMS current through inductor and switches, which results in less conduction loss.

When selecting the inductor, make sure it is able to handle the peak current without saturation even at the highest operating temperature.

The inductor takes the highest current in a buck circuit. The conduction loss on inductor needs to be checked for thermal and efficiency requirements.

Surface mount inductors in different shape and styles are available from Coilcraft, Elytone and Murata. Shielded inductors are small and radiate less EMI noise. But they cost more than unshielded inductors. The choice depends on EMI requirement, price and size.

Output Capacitor

The output capacitor is selected based on the DC output voltage rating, output ripple voltage specification and ripple current rating.

The selected output capacitor must have a higher rated voltage specification than the maximum desired output voltage including ripple. De-rating needs to be considered for long term reliability.

Output ripple voltage specification is another important factor for selecting the output capacitor. In a buck converter circuit, output ripple voltage is determined by inductor value, switching frequency, output capacitor value and ESR. It can be calculated by the equation below:

$$\Delta V_O = \Delta I_L \times \left(ESR_{CO} + \frac{1}{8 \times f \times C_O}\right)$$

where;

C_O is output capacitor value and

ESR_{CO} is the Equivalent Series Resistor of output capacitor.

When a low ESR ceramic capacitor is used as the output capacitor, the impedance of the capacitor at the switching frequency dominates. Output ripple is mainly caused by capacitor value and inductor ripple current. The output ripple voltage calculation can be simplified to:

$$\Delta V_O = \Delta I_L \times \left(\frac{1}{8 \times f \times C_O}\right)$$

If the impedance of ESR at switching frequency dominates, the output ripple voltage is mainly decided by capacitor ESR and inductor ripple current. The output ripple voltage calculation can be further simplified to:

$$\Delta V_O = \Delta I_L \times ESR_{CO}$$

For lower output ripple voltage across the entire operating temperature range, X5R or X7R dielectric type of ceramic, or other low ESR tantalum capacitor or aluminum electrolytic capacitor may also be used as output capacitors.

In a buck converter, output capacitor current is continuous. The RMS current of output capacitor is decided by the peak to peak inductor ripple current. It can be calculated by:

$$I_{CO_RMS} = \frac{\Delta I_L}{\sqrt{12}}$$

Usually, the ripple current rating of the output capacitor is a smaller issue because of the low current stress. When the buck inductor is selected to be very small and inductor ripple current is high, output capacitor could be overstressed.

Schottky Diode Selection

The external freewheeling diode supplies the current to the inductor when the high side NMOS switch is off. To reduce the losses due to the forward voltage drop and recovery of diode, Schottky diode is recommended to use. The maximum reverse voltage rating of the chosen Schottky diode should be greater than the maximum input voltage and size for average forward current in normal condition. Average forward current can be calculated from:

$$I_{D_AVE} = \frac{I_O}{V_{IN}}(V_{IN} - V_{OUT})$$

Loop Compensation

The AOZ1213 employs peak current mode control for easy use and fast transient response. Peak current mode control eliminates the double pole effect of the output L&C filter. It greatly simplifies the compensation loop design.

With peak current mode control, the buck power stage can be simplified to be a one-pole and one-zero system in frequency domain. The pole is dominant pole and can be calculated by:

$$f_{p1} = \frac{1}{2\pi \times C_O \times R_L}$$

The zero is a ESR zero due to output capacitor and its ESR. It can be calculated by:

$$f_{z1} = \frac{1}{2\pi \times C_O \times ESR_{CO}}$$

where;

C_O is the output filter capacitor,

R_L is load resistor value, and

ESR_{CO} is the equivalent series resistance of output capacitor.

The compensation design is actually to shape the converter close loop transfer function to get desired gain and phase. Several different types of compensation network can be used for AOZ1213. For most cases, a series capacitor and resistor network connected to the COMP pin sets the pole-zero and is adequate for a stable high-bandwidth control loop.

In the AOZ1213, FB pin and COMP pin are the inverting input and the output of internal transconductance error amplifier. A series R and C compensation network connected to COMP provides one pole and one zero. The pole is:

$$f_{P2} = \frac{G_{EA}}{2\pi \times C_C \times G_{VEA}}$$

where;

G_{EA} is the error amplifier transconductance, which is 200×10^{-6} A/V,

G_{VEA} is the error amplifier voltage gain, which is 500 V/V, and

C_C is the compensation capacitor

The zero given by the external compensation network, capacitor C_C and resistor R_C , is located at:

$$f_{Z2} = \frac{1}{2\pi \times C_C \times R_C}$$

To design the compensation circuit, a target crossover frequency f_C for close loop must be selected. The system crossover frequency is where control loop has unity gain. The crossover frequency is also called the converter bandwidth. Generally a higher bandwidth means faster response to load transient. However, the bandwidth should not be too high due to system stability concern. When designing the compensation loop, converter stability under all line and load condition must be considered.

Usually, it is recommended to set the bandwidth to be less than 1/10 of switching frequency. It is recommended to choose a crossover frequency less than 30kHz.

$$f_C = 30kHz$$

The strategy for choosing R_C and C_C is to set the crossover frequency with R_C and set the compensator zero with C_C . Using selected crossover frequency, f_C , to calculate R_C :

$$R_C = f_C \times \frac{V_O}{V_{FB}} \times \frac{2\pi \times C_O}{G_{EA} \times G_{CS}}$$

where;

f_C is desired crossover frequency,

V_{FB} is 0.8V,

G_{EA} is the error amplifier transconductance, which is 200×10^{-6} A/V, and

G_{CS} is the current sense circuit transconductance, which is 6.6 A/V

The compensation capacitor C_C and resistor R_C together make a zero. This zero is put somewhere close to the dominate pole f_{p1} but lower than 1/5 of selected crossover frequency. C_C can be selected by:

$$C_C = \frac{1.5}{2\pi \times R_C \times f_{p1}}$$

The equation above can also be simplified to:

$$C_C = \frac{C_O \times R_L}{R_C}$$

An easy-to-use application software which helps to design and simulate the compensation loop can be found at www.aosmd.com.

Linear Regulator Design

Adjustable Output Voltage

The output voltage can be set by feeding back the output to FB2 pin with a resistor divider network. In the application circuit shown in Figure1. The linear regulator output voltage can be obtained using the following equation:

$$V_{OUT2} = 0.8 \times \left(1 + \frac{R3}{R4}\right)$$

$R4$ should be 10k Ω or less to avoid bias current errors.

External NPN Pass Transistor or MOSFET

Both Transistor and MOSFET can be used as an external follower. Some precautions must be followed:

1. The transistor and MOSFET should be able to supply maximum operating current for the linear regulator supply.
2. DC current gain h_{FE} must be large enough so that the pass transistor and supply the maximum load current with 30mA with base current. However, too big of an h_{FE} may cause the LDO to be sensitive to current noise, and as a compromise, a DC current gain transistor should be selected.
3. The total power dissipation should not be higher than the rated value.
4. Compared to a transistor, a MOSFET has lower dropout voltage which is $R_{DS(ON)}$ multiplied by the output current. The minimum input voltage will increase to V_O plus V_{GS} while the transistor is V_O plus V_{BE} .

Linear Regulator Output Capacitor

The linear regulator requires using an output capacitor as part of the frequency compensation network, which affects the stability and high frequency response. The regulator has a finite band width. For high frequency transient loads, recovery from transient is determined by both output capacitor and the bandwidth of the regulator. A minimum output capacitor of 4.7 μ F is recommended to prevent oscillations and provide good transient response.

The ESR value should be maintained in the range that determines the loop stability. When small signal ringing occurs with ceramics due to insufficient ESR in low output voltage condition, adding ESR or increasing the capacitor value improves the stability and reduces the ringing. But too high an ESR is also not suggested, which will cause the zero to be too big and the phase margin is not satisfied. High ESR also brings in high voltage ripple. The lower the output voltage is, the higher the ESR value is needed. Basically, ESR between 0.02 Ω and 3 Ω can make sure the circuit stable.

Solid tantalum electrolytic, aluminum electrolytic, and multilayer ceramic capacitors are all suitable, only if the capacitance and ESR of them meet the requirements.

Output Voltage Ripple

The LDO is designed to provide low output voltage noise while operating at any load. Because of the existence of stray inductance and capacitance, sometimes there could be a big ripple voltage in the output which is unexpected. The following tips could decrease the ripple voltage to a lower value:

1. Improve the PCB layout:
 - Signal grounds should connect to AGND to insure the noise is small,
 - Low side divider resistor connects to AGND directly;.
 - Keep sensitive signal trace such as FB2 pin, LDRV pin as short as possible, and far away from noise trace.
2. Adding a bypass capacitor from FB2 pin to AGND, which will lower the bandwidth of the loop. The impedance of the FB2 pin capacitor at the ripple frequency should be less than the value of R3.
3. Adding a resistor R_G between LDRV and the base of the transistor (gate of MOSFET), which can structure a RC filter with the capacitor of Base-Emitter to reduce the noise (Figure 2). As the increasing of R_G value, the noise getting smaller. Considering the power dissipation of the R_G, its value is often between 10Ω and 100Ω.
4. Increasing the capacitance of output capacitor or add the ESR of the output capacitor.
5. Change the pass transistor to a lower h_{FE} type (MOSFET to a lower g_{FS} type), thus the loop gain can be smaller as a source follower. But the h_{FE} and g_{FS} should be large enough to meet the output current requirement.

Thermal Management and Layout Consideration

In the AOZ1213 buck regulator circuit, high pulsing current flows through two circuit loops. The first loop starts from the input capacitors, to the VIN pin, to the LX pins, to the filter inductor, to the output capacitor and load, and then return to the input capacitor through ground. Current flows in the first loop when the high side switch is on. The second loop starts from inductor, to the output capacitors and load, to the GND pin of the AOZ1213, to the LX pins of the AZO1213. Current flows in the second loop when the low side diode is on.

In PCB layout, minimizing the two loops area reduces the noise of this circuit and improves efficiency. A ground plane is recommended to connect input capacitor, output capacitor, and GND pin of the AOZ1213.

In the AOZ1213 buck regulator circuit, the three major power dissipating components are the AOZ1213, external diode and output inductor. The total power dissipation of converter circuit can be measured by input power minus output power.

$$P_{total_loss} = V_{IN} \times I_{IN} - V_O \times I_O$$

The power dissipation of the inductor can be approximately calculated by output current and DCR of the inductor.

$$P_{inductor_loss} = I_O^2 \times R_{inductor} \times 1.1$$

The power dissipation of the diode is:

$$P_{diode_loss} = I_O \times V_F \times \left(1 - \frac{V_O}{V_{IN}}\right)$$

The actual AOZ1213 junction temperature can be calculated with power dissipation in the AOZ1213 and thermal impedance from junction to ambient.

$$T_{junction} = (P_{total_loss} - P_{inductor_loss}) \times \Theta_{JA} + T_{ambient}$$

The maximum junction temperature of AOZ1213 is 145°C, which limits the maximum load current capability.

The thermal performance of the AOZ1213 is strongly affected by the PCB layout. Extra care should be taken by users during design process to ensure that the IC will operate under the recommended environmental conditions.

Several layout tips are listed below for the best electric and thermal performance. Figure 3 is the layout example.

1. Do not use thermal relief connection to the VIN and the GND pin. Pour a maximized copper area to the GND pin and the VIN pin to help thermal dissipation.
2. Input capacitor should be connected as close as possible to the VIN pin and the GND pin.
3. Make the current trace from LX pins to L to Co to the GND as short as possible.
4. Pour copper plane on all unused board area and connect it to stable DC nodes, like VIN, GND or VOUT.
5. Keep sensitive signal traces such as the trace connecting FB pin and COMP pin away from the LX pins.

Layout Example of the AOZ1213

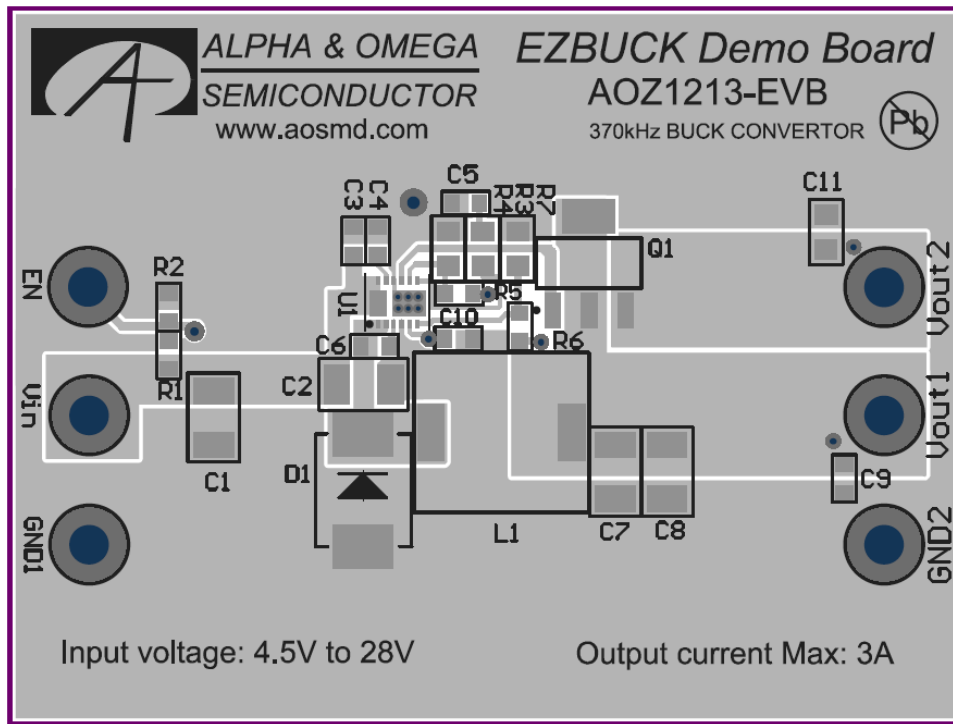

Figure 3a. Top Side

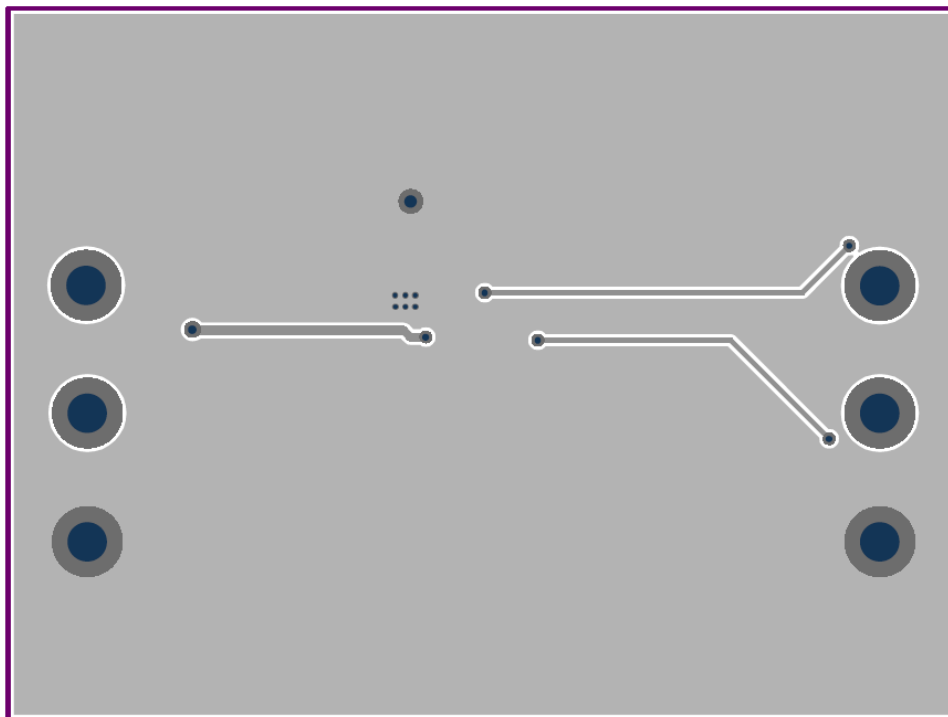
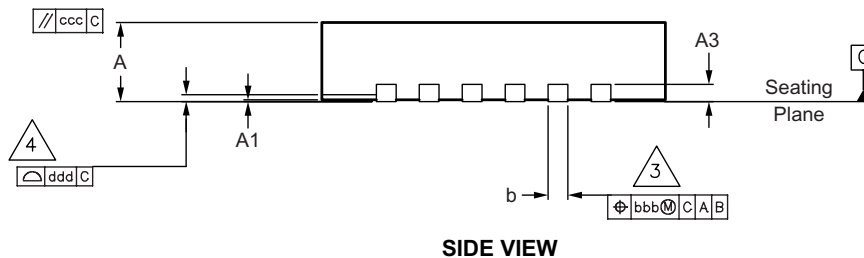
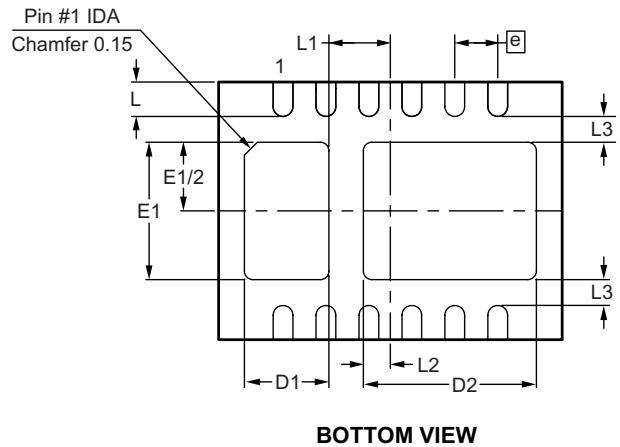
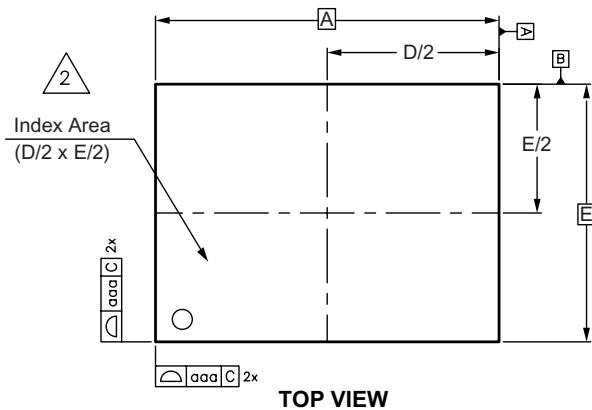
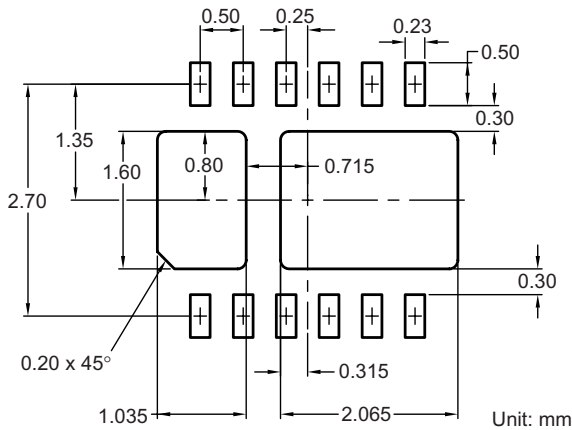

Figure 3b. Bottom Side

Package Dimensions, DFN 4 x 3



RECOMMENDED LAND PATTERN



Dimensions in millimeters

| Symbols | Min. | Nom. | Max. |
|---------|-----------|-------|------|
| A | 0.80 | 0.90 | 1.00 |
| A1 | 0.00 | 0.02 | 0.05 |
| A3 | 0.20 REF. | | |
| b | 0.20 | 0.23 | 0.35 |
| D | 4.00 BSC | | |
| D1 | 0.83 | 0.985 | 1.09 |
| D2 | 1.86 | 2.015 | 2.12 |
| E | 3.00 BSC | | |
| E1 | 1.45 | 1.60 | 1.70 |
| e | 0.50 BSC | | |
| L | 0.30 | 0.40 | 0.50 |
| L1 | 0.61 | 0.715 | 0.82 |
| L2 | 0.21 | 0.315 | 0.42 |
| L3 | 0.30 REF. | | |
| aaa | 0.15 | | |
| bbb | 0.10 | | |
| ccc | 0.10 | | |
| ddd | 0.08 | | |

Dimensions in inches

| Symbols | Min. | Nom. | Max. |
|---------|------------|-------|-------|
| A | 0.031 | 0.035 | 0.039 |
| A1 | 0.000 | 0.001 | 0.002 |
| A3 | 0.008 REF. | | |
| b | 0.008 | 0.009 | 0.014 |
| D | 0.157 BSC | | |
| D1 | 0.033 | 0.039 | 0.043 |
| D2 | 0.073 | 0.079 | 0.083 |
| E | 0.118 BSC | | |
| E1 | 0.057 | 0.063 | 0.067 |
| e | 0.020 BSC | | |
| L | 0.012 | 0.016 | 0.020 |
| L1 | 0.024 | 0.028 | 0.032 |
| L2 | 0.008 | 0.012 | 0.017 |
| L3 | 0.012 REF. | | |
| aaa | 0.006 | | |
| bbb | 0.004 | | |
| ccc | 0.004 | | |
| ddd | 0.003 | | |

Notes:

1. Controlling dimension is millimeter, converted inch dimensions are not necessarily exact.

2. The location of the terminal #1 identifier and terminal numbering conforms to JEDEC publication 95 SPP-002.

3. Dimension b applied to metallized terminal and is measured between 0.20mm and 0.35mm from the terminal tip. If the terminal has the optional radius on the other end of the terminal, dimension b should not be measured in that radius area.

4. Coplanarity ddd applies to the terminals and all other bottom surface metallization.

Tape and Reel Dimensions, DFN 4 x 3

Carrier Tape

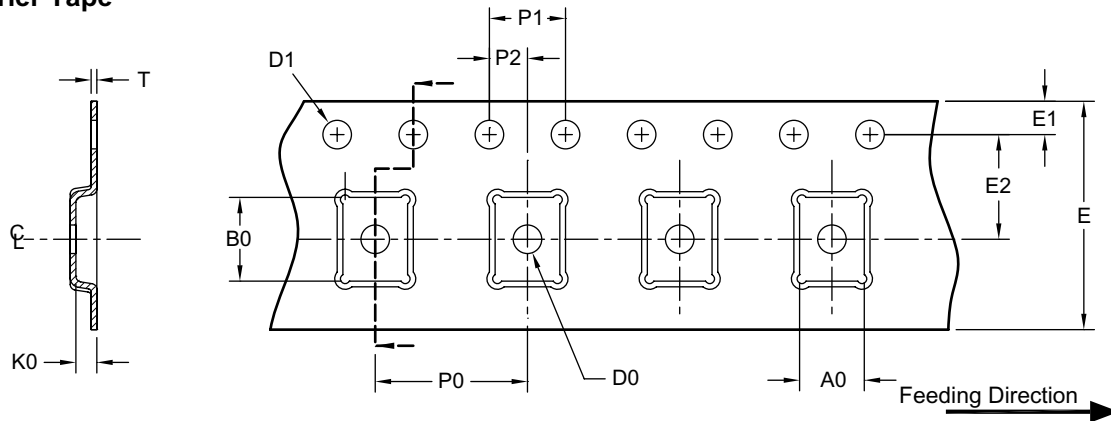

UNIT: mm

| Package | A0 | B0 | K0 | D0 | D1 | E | E1 | E2 | P0 | P1 | P2 | T |
|----------------------|---------------|---------------|---------------|--------------|--------------------|--------------|---------------|---------------|---------------|---------------|---------------|---------------|
| DFN 4 x 3 (12 mm) | 3.40 ±0.10 | 4.40 ±0.10 | 1.10 ±0.10 | 1.50 Min. | 1.50 +0.10/-0.0 | 12.0 ±0.3 | 1.75 ±0.10 | 5.50 ±0.05 | 8.00 ±0.10 | 4.00 ±0.10 | 2.00 ±0.10 | 0.30 ±0.05 |

Reel

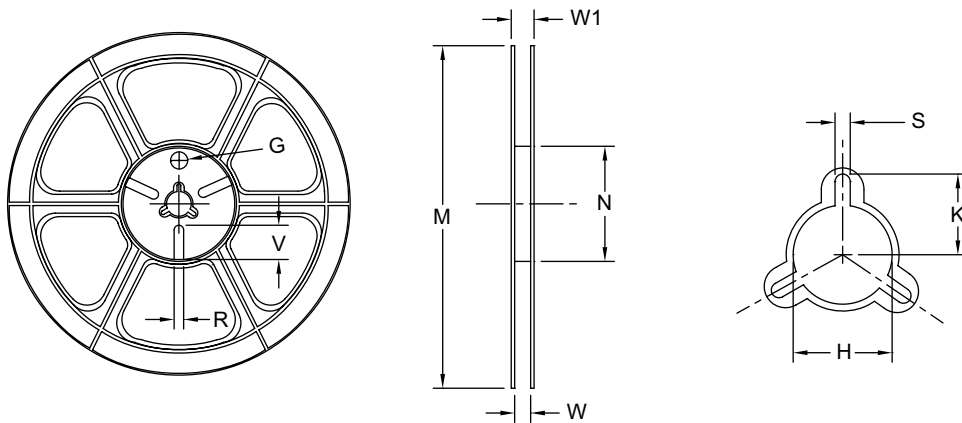

UNIT: mm

| Tape Size | Reel Size | M | N | W | W1 | H | K | S | G | R | V |
|-----------|-----------|----------------|---------------|-----------------|-----------------|---------------|--------------|-------------|---|---|---|
| 12mm | ø330 | ø330.0 ±2.0 | ø79.0 ±1.0 | 12.4 +2.0/-0 | 17.0 +2.6/-0 | ø13.0 ±0.5 | 10.5 ±0.2 | 2.0 ±0.5 | — | — | — |

Leader / Trailer & Orientation

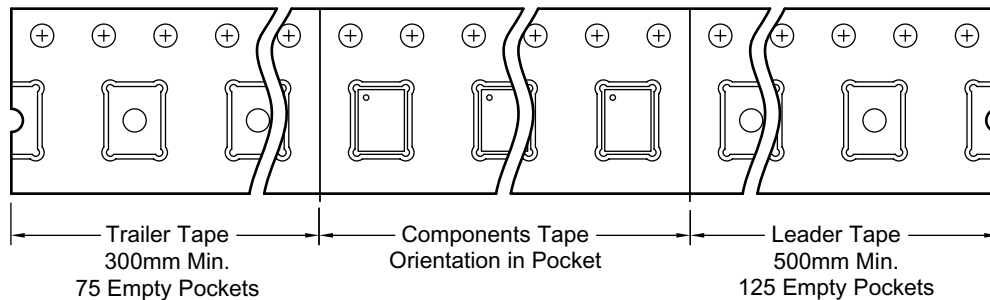

Package Marking

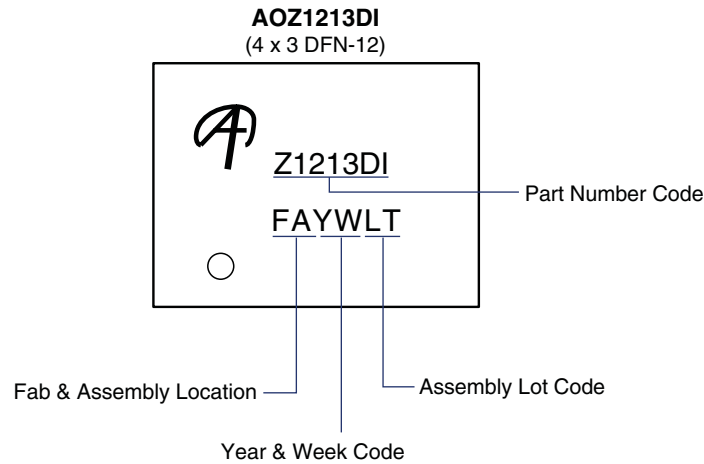

Alpha & Omega Semiconductor reserves the right to make changes at any time without notice.

LIFE SUPPORT POLICY

ALPHA & OMEGA SEMICONDUCTOR PRODUCTS ARE NOT AUTHORIZED FOR USE AS CRITICAL COMPONENTS IN LIFE SUPPORT DEVICES OR SYSTEMS.

As used herein:

- | | |
|---|---|
| <p>1. Life support devices or systems are devices or systems which, (a) are intended for surgical implant into the body or (b) support or sustain life, and (c) whose failure to perform when properly used in accordance with instructions for use provided in the labeling, can be reasonably expected to result in a significant injury of the user.</p> | <p>2. A critical component in any component of a life support, device, or system whose failure to perform can be reasonably expected to cause the failure of the life support device or system, or to affect its safety or effectiveness.</p> |
|---|---|