

Operator's Manual

Series 5017

Model 5017A

Model 5017B

Model 5017C

Model 5017D

Model 5017E

Model 5017F

Model 5017G

Model 5017H

MAN-5017 Rev A



**2015 West Chestnut Street
Alhambra, California 91803**

(626) 293-3400

Fax: (626) 293-3428

www.emcore.com

Disclaimer

Every attempt has been made to make this material complete, accurate, and up-to-date. Users are cautioned, however, that Ortel reserves the right to make changes without notice and shall not be responsible for any damages, including consequential, caused by reliance on the material presented, including, but not limited to, typographical, arithmetical, or listing errors.

Copyright Information

© 2006 by Ortel

Ortel, A Division of Emcore
Alhambra, California, 91803, USA

May 2006

WARNINGS, CAUTIONS, AND GENERAL NOTES

Safety Considerations

When installing or using this product, observe all safety precautions during handling and operation. Failure to comply with the following general safety precautions and with specific precautions described elsewhere in this manual violates the safety standards of the design, manufacture, and intended use of this product. Ortel assumes no liability for the customer's failure to comply with these precautions.



Calls attention to a procedure or practice, which if ignored, may result in damage to the system or system component. Do not perform any procedure preceded by a CAUTION until described conditions are fully understood and met.

Electrostatic Sensitivity

ESD = Electrostatic Sensitive Device

Observe electrostatic precautionary procedures.

Semiconductor laser transmitters and receivers provide highly reliable performance when operated in conformity with their intended design. However, a semiconductor laser may be damaged by an electrostatic charge inadvertently imposed by careless handling.

Static electricity can be conducted to the laser chip from the center pin of the RF input connector, and through the DC connector pins. When unpacking and otherwise handling the transmitter, follow ESD precautionary procedures including use of grounded wrist straps, grounded workbench surfaces, and grounded floor mats.

Exposure to electrostatic charge is greatly reduced after the transmitter has been installed in an operational circuit.

If You Need Help

If you need additional help in installing or using the system, need additional copies of this manual, or have questions about system options, please call Ortel's Sales Department.

Service

Do not attempt to modify or service any part of the system other than in accordance with procedures outlined in this Operator's Manual. If the system does not meet its warranted specifications, or if a problem is encountered that requires service, return the apparently faulty plug-in or assembly to Ortel for evaluation in accordance with Ortel's warranty policy.

When returning a plug-in or assembly for service, include the following information: Owner, Model Number, Serial Number, Return Authorization Number (obtained in advance from Ortel's Customer Service Department), service required and/or a description of the problem encountered.

Warranty and Repair Policy Warranty and Repair Policy Warranty and Repair Policy Warranty and Repair Policy Warranty and Repair Policy

The Ortel Quality Plan includes product test and inspection operations to verify the quality and reliability of our products.

Ortel uses every reasonable precaution to ensure that every device meets published electrical, optical, and mechanical specifications prior to shipment. Customers are asked to advise their incoming inspection, assembly, and test personnel as to the precautions required in handling and testing ESD sensitive opto-electronic components.

These products are covered by the following warranties:

1. General Warranty

Ortel warrants to the original purchaser all standard products sold by Ortel to be free of defects in material and workmanship for one (1) year from date of shipment from Ortel. During the warranty period, Ortel's obligation, at our option, is limited to repair or replacement of any product that Ortel proves to be defective. This warranty does not apply to any product, which has been subject to alteration, abuse, improper installation or application, accident, electrical or environmental over-stress, negligence in use, storage, transportation or handling.

2. Specific Product Warranty Instructions

All Ortel products are manufactured to high quality standards and are warranted against defects in workmanship, materials and construction, and to no further extent. Any claim for repair or replacement of a device found to be defective on incoming inspection by a customer must be made within 30 days of receipt of the shipment, or within 30 days of discovery of a defect within the warranty period.

This warranty is the only warranty made by Ortel and is in lieu of all other warranties, expressed or implied, except as to title, and can be amended only by a written instrument signed by an officer of Ortel. Ortel sales agents or representatives are not authorized to make commitments on warranty returns.

In the event that it is necessary to return any product against the above warranty, the following procedure shall be followed:

- a. Return authorization shall be received from the Ortel Sales Department prior to returning any device. Advise the Ortel Sales Department of the model, serial number, and the

discrepancy. The device shall then be forwarded to Ortel, transportation prepaid. Devices returned freight collect or without authorization may not be accepted.

- b. Prior to repair, Ortel Sales will advise the customer of Ortel test results and will advise the customer of any charges for repair (usually for customer caused problems or out-of-warranty conditions).

If returned devices meet full specifications and do not require repair, or if non-warranty repairs are not authorized by the customer, the device may be subject to a standard evaluation charge. Customer approval for the repair and any associated costs will be the authority to begin the repair at Ortel. Customer approval is also necessary for any removal of certain parts, such as connectors, which may be necessary for Ortel testing or repair.

- c. Repaired products are warranted for the balance of the original warranty period, or at least 90 days from date of shipment.

3. **Limitations of Liabilities**

Ortel's liability on any claim of any kind, including negligence, for any loss or damage arising from, connected with, or resulting from the purchase order, contract, or quotation, or from the performance or breach thereof, or from the design, manufacture, sale, delivery, installation, inspection, operation or use of any equipment covered by or furnished under this contract, shall in no case exceed the purchase price of the device which gives rise to the claim.

EXCEPT AS EXPRESSLY PROVIDED HEREIN, ORTEL MAKES NO WARRANTY OF ANY KIND, EXPRESSED OR IMPLIED, WITH RESPECT TO ANY GOODS, PARTS AND SERVICES PROVIDED IN CONNECTION WITH THIS AGREEMENT INCLUDING, BUT NOT LIMITED TO, THE IMPLIED WARRANTIES OF MERCHANTABILITY AND FITNESS FOR A PARTICULAR PURPOSE. ORTEL SHALL NOT BE LIABLE FOR ANY OTHER DAMAGE INCLUDING, BUT NOT LIMITED TO, INDIRECT, SPECIAL OR CONSEQUENTIAL DAMAGES ARISING OUT OF OR IN CONNECTION WITH FURNISHING OF GOODS, PARTS AND SERVICE HEREUNDER, OR THE PERFORMANCE, USE OF, OR INABILITY TO USE THE GOODS, PARTS AND SERVICE.

Ortel will not be responsible for loss of output or reduced output of opto-electronic devices if the customer performs chip mounting, ribbon bonding, wire bonding, fiber coupling, fiber connectorization, or similar operations. These processes are critical and may damage the device or may affect the device's output or the fiber output.

Ortel test reports or data indicating mean-time-to-failure, mean-time-between-failure, or other reliability data are design guides and are not intended to imply that individual products or samples of products will achieve the same results. These numbers are to be used as management and engineering tools, and are not necessarily indicative of expected field operation. These numbers assume a mature design, good parts, and no degradation of reliability due to manufacturing procedures and processes.

Ortel is not liable for normal laser output degradation or fiber coupling efficiency degradation over the life of the device.

This fiberoptic laser transmitter contains a class IIIb laser product as defined by the U.S. Department of Health and Human Services, Public Health Service, Food and Drug Administration. This laser product complies with 21 CFR, Chapter I, Subchapter J of the DHEW standards under the Radiation Control for Health and Safety Act of 1968. The laser module certification label is located on the top of the transmitter enclosure and it also shows the required **DANGER** warning logotype.



The Ortel laser products are used in optical fiber communications systems for radio frequency and microwave frequency analog fiberoptic links. In normal operation, these systems are fully enclosed and fully shielded by the hermetically sealed laser metal package. Laser bias current is limited by the internal control circuitry. The transmitters are coupled to glass fiber and have 1300 nm optical output wavelength with typically .5 to 7 mW output power depending on the model. The optical radiation is confined to the fiber core. Under these conditions, there is no accessible laser emission and hence no hazard to safety or health. Variations in the different models reflect the bandwidth, optical output, noise, and distortion of the laser.

Since there is no human access to the laser output during system operation, no special operator precautions are necessary when fiber is connected to the transmitter and receiver. During installation, service or maintenance, the service technician is warned, however, to take precautions, which include not looking directly into the fiber connector or the fiber, which is connected to the fiber connector before it is connected to the fiberoptic receiver. The light emitted from the fiberoptic connector or any fiber connected to the connector is invisible and may be harmful to the human eye. Use either an infrared viewer or fluorescent screen for optical output verification. All handling precautions as outlined by the FDA and ANSI Z136.2 and other authorities of class IIIb lasers must be observed.

Table of Contents

Chapter 1	General Information	8
	Description.....	8
	Specification	8
	Identification and Model Numbers.....	10
	Options	11
Chapter 2	Safety Precautions	12
	ESD Sensitive.....	12
	Power Supply	12
	Input RF Power.....	12
	Grounding	12
	Storage	12
Chapter 3	Operation.....	13
	Theory of Operation.....	13
	External Displays and Controls	13
	LED Displays	13
	Status Monitors.....	13
	Alarm Functions.....	14
	Internal Control Circuits.....	14
	Optical Power Stabilization.....	14
	Temperature Stabilization	15
Chapter 4	Installation and Setup Procedures	16
	Unpacking and Visual Inspection	16
	Operating Conditions.....	16
	Connection Instructions.....	16
	Electrical Connections.....	16
	DC Connection	16
	RF Connection.....	17
Chapter 5	Performance Verification Procedures.....	18
	Broadband Amplitude Response and VSWR.....	18
	Noise Figure Measurement	19
	Linearity Test - Two Carrier Test.....	21

Chapter 1 - General Information

1.1 DESCRIPTION

This manual describes the following fiberoptic transceivers model numbers:

5017A/B/C/D/E/F/G/H

These fiberoptic products are designed to carry RF and microwave signals using singlemode optical fiber. They contain InGaAsP high-speed semiconductor lasers and photodiodes in a patented high-speed package. Featured in the package is a coaxial input and a built-in thermoelectric cooler (TEC). The 5017 A/B/C/D/E/F/G/H uses a high performance, internally isolated DFB laser operating at a wavelength of 1310 nm.

The 5017x contains electronic circuits to operate the optical components over the operating temperature range of the product. Also, status monitoring and alarm circuits are included for use in systems that require self-diagnosis and failure analysis.

The signal input is via a coaxial SMA connector in a 50 ohm input circuit. The 5017A/B/C/D uses and internal spool with a max delay of 8 μ -sec and the 5017E/F/G/H uses and external spool mounted to the lid with a max delay of 110 μ -sec

1.2 SPECIFICATIONS

For detailed specifications of an individual product described in this manual, consult the Product Specification Table (PST) included with your manual. If the PST, is missing you can obtain a duplicate from the Ortel Sales Department, (626) 293-3400.

Specifications apply over the entire specified operating range of the product and are guaranteed for 1 year after the date of purchase.

PRODUCT SPECIFICATION

RF Parameters

Frequency Range	
5017A/E	0.1 to 4 GHz
5017B/F	0.1 to 10 GHz
5017C/G	0.1 to 15 GHz
5017D/H	0.1 to 18 GHz
Insertion Loss (5017A/B/C/D)	-44 dB
Insertion Loss (5017E/F/G/H)	-58 dB
Amplitude Response	
"A" and "E" Versions	3 dB p-p
"B" and "F" Versions	4 dB p-p
"C" and "G" Versions	5 dB p-p
"D" and "H" Versions	6 dB p-p
Input/Output Impedance	50 Ω
Input Return Loss	
5017 A/B/E/F	-9.6 dB
5017 C/D/G/H	0.1 to 10 GHz -9.6 dB 10.1 to 18 GHz -6.0 dB
Output Return Loss	
5017 A/B/E/F	-9.0 dB
5017 C/D/G/H	0.1 to 10 GHz -9.0 dB 10.1 to 18 GHz -6.0 dB
Input 1 dB Compression (typ)	+20 dBm
Input Third Order Intercept	
100 MHz to 4.0 GHz	> +30 dBm
4.0 to 18.0 GHz	> +25 dBm
Noise Figure (dB) 5017 A/B/C/D	
100 MHz	44 dB
4 GHz	49 dB
10 GHz	54 dB
15 GHz	64 dB
18 GHz	69 dB

Noise Figure (dB) 5017 E/F/G/H	
100 MHz	54 dB
4 GHz	59 dB
10 GHz	64 dB
15 GHz	74 dB
18 GHz	79 dB

Optical Parameters

Fiber Connectors singlemode (9/125)
FC/APC

DC Power Requirements

+15 V @ 300 mA (max)
+5 V @ 1.6 A @ +65°C

Maximum Ratings

Input Power +20 dBm/60 sec
Operating Temperature -20 to 65°C
Storage Temperature -40 to 85°C

Mechanical Dimensions

Height 2.37 in
Width 6.0 in
Depth 6.0 in

RF Connector
DC Connector

SMA (F)
D-sub 9 pin

DC Pinout	
Pin No	Function
1	+15 Vdc
2	+5 Vdc
3	NC
4	Power Ground
5	Ref. Ground
6	Laser Photodiode Monitor
7	Received optical power
8	Laser current monitor
9	Over temperature alarm

1.3 IDENTIFICATION AND MODEL NUMBERS

Each Ortel product is assigned a unique model number and serial number, which appears on the label of the transmitter. Model numbers for this series have the form

5017X-*nnn*

where 'X' is a letter designation specifying the model (A, B, C, D, E, F,G and H) and 'nnn' is a three digit numeric designation for the appropriate optical connector option.

1.3.1 OPTIONS

Changes to the PST can; be accommodated by requesting non-standard options to meet specific performance requirements. Such options are designated by an alpha-numeric suffix,

-XNN

where X is alpha, and NN is numeric. Such custom options must be agreed upon in advance with the Ortel Sales Department.

Chapter 2 - Safety Precautions

2.1 ESD SENSITIVE

Semiconductor lasers and photodiodes are static sensitive devices, and products containing them should be treated accordingly. Static electricity can be conducted to the laser chip from the center pin of the RF input SMA connector, and through the DC connector pins. When unpacking and handling the delay line, prior to install action, use ESD precautionary procedures such as grounded wrist straps and grounded work mats.

After the delay line is installed in an operational circuit, these pins are protected from casual contact and ESD sensitivity is greatly reduced.

2.2 POWER SUPPLY

A power supply is required to provide power to the laser, the photodiode and to the temperature control circuits. Operating the delay line outside of its recommended power supply values may cause damage to the product. Damage can occur to the laser if the delay line is operated with one or more supply voltages set improperly. It is recommended that the supply voltages be turned on simultaneously after the connections have been made to the 9-pin connector. For best results, avoid connecting the 9-pin connector to the delay line housing while the power supply is on (see Section 3.3 for connection instructions before applying power).

2.3 INPUT RF POWER

The laser diode can be overdriven and damaged by the application of excessive RF power. Refer to the specific Product Specification Table for information about the maximum permissible RF power to the delay line. Do not apply RF power with the delay line turned off.

2.4 GROUNDING

All power supplies should be connected to an earth ground.

2.5 STORAGE

Observe ESD precautions while storing the delay line (i.e., anti-static containers) and store away from corrosive materials. Storage temperature: -40 to 85°C.

Chapter 3 - Operation

THEORY OF OPERATION

The Model 5017 series fiberoptic delay line uses an Ortel high-speed laser module to generate an intensity modulated optical signal at 1300 nm wavelength. The 5017 A/B/C/D/E/F/G/H uses a high performance distributed feedback (DFB) laser with a built-in optical isolator. This signal is sent through a length of singlemode optical fiber and received by a high-speed photodiode, which outputs the RF signal. For more complete information on the operating principles of analog fiberoptic links, consult Ortel's RF/Microwave Fiberoptic Link Design Guide.

3.1 EXTERNAL DISPLAYS AND CONTROLS

There are no external controls or adjustments. The laser current is preset at the factory to provide optimum performance according to the specifications published in the data sheet and the Product Specification Table.

3.1.1 LED DISPLAYS

There is one externally visible LED that provides information about the operating state of the delay line. This LED is normally on. If it is off after applying dc power to the delay line and waiting for a few seconds, recheck all power connections. If the condition persists, consult with Ortel's Customer Service department.

POWER ON: This LED is normally ON, and indicates that +15 V is present at Pin #1 of the dc 9-pin connector.

3.1.2 STATUS MONITORS

Three monitor voltages are available on the dc connector. They are designed to provide information about the operating condition of internal optical power circuits for routine operational maintenance.

PIN 6: Laser Photodiode Current Monitor. 1 V/mA, $\pm 2\%$ (1.0 M Ω load). Provides a buffered voltage proportional to the photodiode current.

PIN 7: Received Low optical Power. 1 V/mA, $\pm 2\%$ (1.0 M Ω load). Provides a buffered voltage proportional to the photodiode current.

PIN 8: Laser DC Current Monitor. 1 V/100 mA, $\pm 2\%$ (1.0 M Ω load). Provides a buffered voltage proportional to the laser dc current. Measuring and recording this voltage provides a record of the laser current over time. The normal range is 0.3 to 0.75 V (30 to 75 mA).

3.1.3 ALARM FUNCTIONS

The alarm is designed to interface with user-supplied circuits. The alarm is an open collector output capable of sinking 20 mA when ON and withstanding 15 Vdc when OFF. Normal operation of the alarm circuit is the OFF state. A suggested use of the alarm circuit would be a series connection of an external LED, or a relay, from the system 15 V supply through a 1 k Ω resistor. Assuming negligible voltage drop through the LED or relay, this would provide a 15 mA activation current when the alarm is active.

The alarm function and pin assignment is as follows.

PIN 9: Laser Temperature. This alarm is ON (sinks current) if the laser substrate temperature is more than 2°C higher than the factory setpoint. The alarm is not activated if the temperature is LOWER than the setpoint.

3.2 INTERNAL CONTROL CIRCUITS

The laser module contained in this delay line contains two sensing elements to provide feedback on the operating conditions of the laser. They are, a monitor photodiode, which provides a current proportional to the output power of the laser chip, and a thermistor, which provides information about the temperature of the laser substrate. The entire substrate is mounted on a Peltier Cooler (thermoelectric cooler), which can heat or cool the laser substrate as necessary to maintain a constant operating temperature for the laser chip.

The 5000 series delay line contains two feedback control circuits, which use these sensing elements to maintain stable operation.

3.2.1 OPTICAL POWER STABILIZATION

The optical power control circuit senses the current generated by the monitor photodiode and compares the resulting voltage against a reference voltage, which is preset at the factory. A feedback circuit drives a highly stabilized current source, which provides the dc current for the laser operation. This mode of operation is known as "constant power". As the laser ages, the control circuit will maintain the optical output power, as sensed by the internal photodiode, constant by adjusting the laser current to compensate for changes in chip operating temperature, threshold current, and quantum efficiency. The power control circuit will not compensate for changes in the laser/fiber coupling efficiency.

In addition to the dc current supply circuit; there are two additional circuits in the optical power control circuit. A "slow start" circuit operates when the delay line is switched on. This circuit increases the laser current over 3 seconds from zero to its operating value. This eliminates transients and which could damage the laser. A current limiter, preset at the factory, establishes a maximum value for the laser current. Thus, a failure of the monitor photodiode will not result in uncontrolled laser current values, which would destroy the laser.

3.2.2 TEMPERATURE STABILIZATION

The temperature control circuit senses the thermistor resistance in the laser module and compares it against a variable reference, which is preset at the factory. The error voltage drives an integrator, which supplies current to the T/E cooler (TEC). The current source is bipolar, so heating and cooling functions are provided to the TEC.

As with the power control circuit, a current limiter prevents the TEC and laser from damage due to excessive heating or cooling functions should the thermistor fail.

Chapter 4 - Installation and Setup Procedures

4.1 UNPACKING AND VISUAL INSPECTION

The product described herein was inspected before shipment and found to be free of mechanical and electrical defects. Observe ESD precautions while handling the delay line. Unpack and examine the product for any damage due to shipping. Keep all packing materials until you are satisfied that the product works according to specifications. Verify that the pins and connectors are free from obvious shipping or handling damage. If damage is discovered, file a claim with the carrier immediately. Notify the Ortel Sales Department as soon as possible.

4.2 OPERATING CONDITIONS

This product is designed and tested to withstand harsh environmental operating and storage conditions. The basic design and manufacturing processes have been subjected to rigorous product qualification tests of temperature cycling, mechanical shock, and vibration. Every product is warranted to operate within specification over the temperature range from -20 to 65°C, and to withstand storage temperatures from -40 to 85°C without degradation.

4.3 CONNECTION INSTRUCTIONS

To operate the 5017 at room temperature in a laboratory setting, it can be placed on a convenient flat surface without any particular concern for a good heatsink. In a field-operating environment, to obtain reliable operation over the full temperature range, make the fiberoptic connections before applying power to the 5017.

4.3.1 ELECTRICAL CONNECTION

Observe the following procedures while making electrical connection to the delay line.

4.3.1.1 DC CONNECTION

Connect the transmitter to the required dc voltages using a standard 9-pin DSUB connector. Do not solder wires directly to the pins of the dc connector. The delay line contains internal regulator and transient suppression circuits. Most high quality power supplies will provide excellent results. For best results, make the dc connection to the transmitter before switching on the supply.

When turning the transmitter on, there is a "slow start" circuit that introduces a 2-3 second delay in the turn on. When the LED's are all lit, the 5017 is ready to use.

4.3.1.2 RF CONNECTION

Apply RF power *only* after DC power has been applied. Connect the RF signal source to the SMA input connector. Absolute maximum signal level shall not exceed 100 mW.

CAUTION: Do not apply excessive torque to the SMA connector. The use of standard wrenches can lead to a damaged connector. Use 7-9 inch pounds of torque. The use of a torque wrench is *strongly recommended*.

The input impedance of the delay line is 50 ohms. Use signal sources with the same characteristic impedance. Consult the Product Specification Table for the maximum input signal level. Do not exceed this level to avoid damaging the laser diode.

Chapter 5 - PERFORMANCE VERIFICATION PROCEDURES

5.1 Broadband Amplitude Response and VSWR

Test Set-Up: See Figure 1. Amplitude and VSWR can be measured with a scalar network analyzer and a sweeper.

1. Set up the HP8510B network analyzer in the frequency domain with the following parameters;

Source Power	+10 dBm
Step Sweep	801 Points
Start Frequency	1.0 GHz
Stop Frequency	4.0 GHz; "A" versions (set the marker at 4 GHz) 10.0 GHz; "B" versions (set the marker at 10 GHz) 15.0 GHz; "C" versions (set the marker at 15 GHz) 18.0 GHz; "D" versions (set the marker at 18 GHz)

2. Perform a response calibration (you only need the "THRU" connection for this).
3. Connect the delay line- port 1 of the test set to the device input and port 2 to the device output.
4. Press "Restart Measurement".
5. When the measurement is done, press "Channel 1" and "S₂₁" and "Log Mag".
6. Set the vertical scale for 5 dB/div, the Reference Level and the Reference Position so that the response is clearly visible in the upper half of the screen. If you are not measuring the phase response skip to step 12.

VSWR

7. Return to a single channel display. Then, press "Channel 1" and S₁₁.
8. Go to the "Format" menu and press the SWR soft key. Set the vertical scale to 0.5/div. Set the Reference Level to 1.0 and adjust the Reference Position so that the trace is clearly visible on the screen.
9. Press "Channel 2" and "S₂₂". Repeat step 16 above.
10. Press "Display", "Dual Channel" then "Overlay" to display S₁₁ and S₂₂ simultaneously. Adjust the Reference Positions as necessary so that both traces are clearly displayed.
11. Activate the markers. Set Marker 1 at 1 GHz and Marker 2 at 4 GHz for "A" and "E" versions, 10GHz for "B" and "F" versions, 15 GHz for "C" and "G" versions and 18 GHz for "D" and "H" versions.
12. Verify that the input and output VSWR (S₁₁ and S₂₂) are less than the specification in the region between the markers.

- 5.2 13. Activate the Copy menu and copy all on the plotter.
Noise Figure Measurement

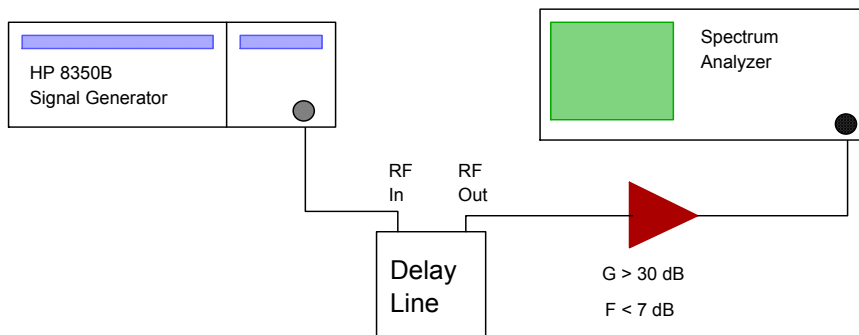

Figure 2 - Test Set-up: Signal to Noise

1. Connect equipment as shown in the figure.
2. Set the signal generator to CW and set the output power so that the power into the delay line is +0 dBm. Perform the signal to noise test at the following frequencies:

"A" and "E" version	1.0, 4.0 GHz
"B" and "F" version	1.0, 4.0, 10.0 GHz
"C" and "G" version	1.0, 7.0, 15.0 GHz
"D" and "H" version	1.0, 7.0, 15.0, 18.0 GHz

3. Set up the spectrum analyzer as follows:
 - a. Center frequency frequency under test
 - b. Span 50 MHz
 - c. ATTEN 0 dB
 - d. Scale 10 dB/div
 - e. RES BW 1 MHz
 - f. VID BW 300 Hz
4. Activate the marker. Perform a peak search, then set marker to reference level.
5. Verify that the noise floor displayed on the spectrum analyzer is at least 10 dB higher than it is with the delay line disconnected.
6. Set the marker 15 MHz above the carrier. Using the marker menu activate the noise density measurement. The marker display will now be in dBm/Hz. Turn off the RF signal and take the difference between the displayed noise density and the reference level. Since the input signal is 0 dBm, this difference is the equivalent input noise. Add 174 dB to this number to get the noise figure. Verify that it meets the specification.
7. Repeat this procedure at the other frequencies.

5.4 Linearity Test - Two Carrier Test

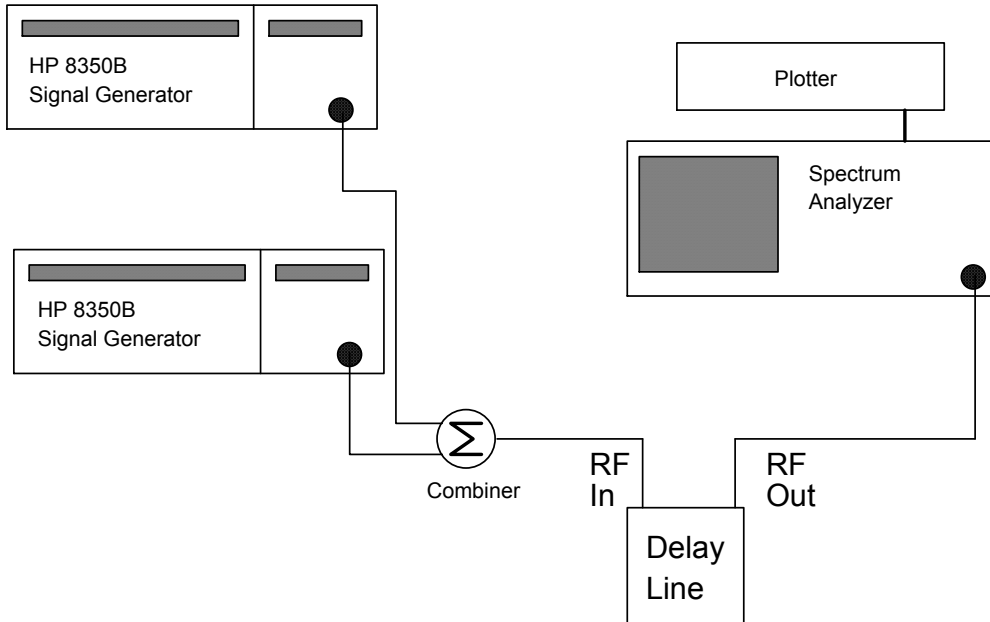

Figure 3 - Test Set-up: Two Tone Test

1. Connect the outputs of the two signal generators to the inputs of the combiner and connect the combiner output to the spectrum analyzer input.
2. Set the frequency of one generator at 3.98 GHz and the other at 4.00 GHz. Adjust the output power levels to +0 dBm per carrier (power into the delay line) and the analyzer center frequency at 3.99 GHz.
3. Connect the combiner output to the delay line input and the delay line output to the spectrum analyzer input.

4. Set the center frequency to 3.98 GHz and the SPAN at 100 MHz. Leave the RES BW and the VID BW on AUTO. Set the ATTEN to 10 dB. Set the reference level and position so that the carriers are at the top line on the display.
5. Activate the marker and set at the peak of the upper carrier. Activate the delta marker and set it at the upper third order intermodulation product. If the level of the third IM is very unstable (noisy) set the analyzer to take 5 - 10 video averages.
6. Verify that the third order intermodulation products are at least $-2(\text{TOI} - P_{\text{in}3})$ dBc (where TOI is the input third order intercept from the product specification and $P_{\text{in}3}$ is the input rf power/tone). For example, if $\text{TOI} = +25$ dBm and $P_{\text{in}3} = 0$ dBm, the IMs should be < -50 dBc (dB relative to the carrier).
7. For "B" and "E" versions repeat the above steps setting one generator to 9.00 GHz and the other to 9.05 GHz and the analyzer center frequency at 9.02 GHz. For "C" and "G" versions, set oscillator frequencies at 14.40 and 14.50GHz and the analyzer center frequency at 14.45 GHz; and for "D" versions, set oscillator frequencies at 17.40 and 17.50 GHz and the analyzer center frequency at 17.45 GHz. Verify that the third order intermodulation products are at least $-2(\text{TOI} - P_{\text{in}3})$ dBc.