

5017C / 5017G 15 GHz Fiber-Optic Delay Line



The 5017D and 5017H 15 GHz delay line delivers unmatched performance for radar testing, signal processing, phased antenna array, and phase noise testing. These rugged devices eliminate many of the problems that are inherent in alternative transceiver technologies.

Ortel's fiber-optic transceivers provide bandwidth that is essentially independent of fiber length, loss or delay, and triple transit signals that are immeasurable. In addition to enhanced electrical performance, the delay lines provide several mechanical advantages. Ortel's technology takes advantage of the rigid yet flexible properties of fiber-optic cable to provide enhanced phase and group delay characteristics. The small size of these components allows for a long delay in a compact package with the superior temperature stability of fiber.



Ordering Information

Model Number	Description
5017C-XXXX	Transceiver, 15 GHz, SMA, 8 μ-sec max
5017G-XXXX	Transceiver, 15 GHz, SMA, 110 μ-sec max

Features

- Bandwidth to 15 GHz
- High dynamic range
- -40 to +65 C
- 1310 nm
- Flat frequency response
- Low phase noise

Applications

- Radar testing
- Signal processing
- Phased antenna array
- Phase noise processing
- Antenna remoting

Delay Time XXXX = X (hundreds) X (Tens) X (Ones) X (Tenths)

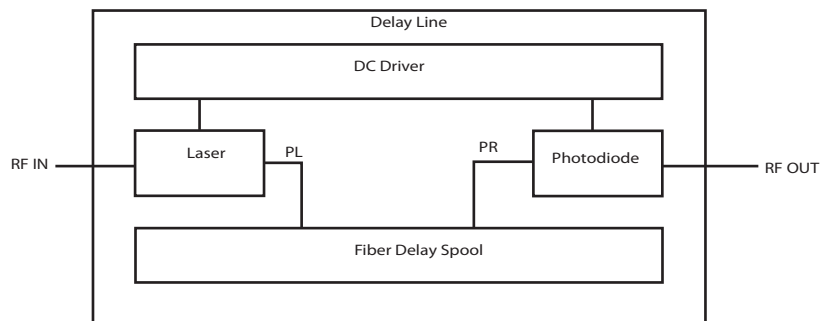
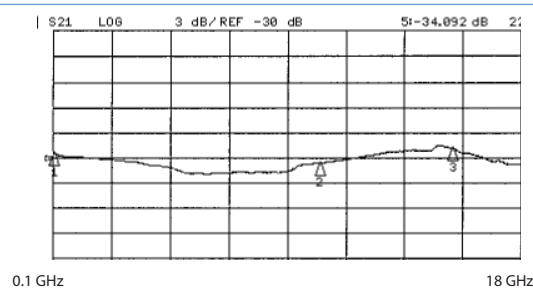

5017C / 5017G

15 GHz Fiber-Optic Delay Line



MICROWAVE

Absolute Maximum Ratings

Stresses in excess of the absolute maximum ratings can cause permanent damage to the device. These are absolute stress ratings only. Functional operation of the device is not implied at these or any other conditions in excess of those given in the operational sections of the data sheet. Exposure to absolute maximum ratings for extended periods can adversely affect device reliability.

Parameter	Min	Max	Unit
Operating Temperature Range of Baseplate	-40	+65	°C
Storage Temperature	-55	+85	°C
RF Input Power	-	20	dBm

DC Interface Characteristics

Pin Number	Min	Typ	Max	Max Ripple	Current
1	14V	15V	16V	100 mV p-p	0.3 A max
2	4.5V	5V	5.5V	200 mV p-p	1.6 A max

Front Panel LEDs

- Power On

Pin/Package Information

Nine-Pin, Male D-sub Connector

Pin Number	Function
1	+15 Vdc
2	+5 Vdc
3	Not Used
4	Ground
5	Ground
6	Laser Photodiode Current Monitor
7	Photodiode Current Monitor
8	Laser Current Monitor
9	Laser Over Temperature Alarm ¹

1. Open Collector Output

Laser Safety

This product emits no optical radiation, therefore it is considered eye safe.

However it does contain a Class IIIB laser, so be serviced only by Emcore.

RF Interface - SMA Female

dc Monitor Voltages

- Laser Photodiode Current, pin 6
1V/1mA (into 1 MOhm load). Proportional to laser optical power
- Photodiode Current, pin 7
1V/1mA (into 1 MOhm load). Proportional to laser optical power
- Laser DC Current, pin 8
1V/100mA (into 1 MOhm load)

Alarm Circuits

- Laser Over Temperature Alarm, pin 9
Laser Temperature. This alarm is ON (sinks current) if the laser substrate temperature is more than 2 °C higher than the factory setpoint. The alarm is not activated if the temperature is LOWER than the setpoint.

5017C / 5017G

15 GHz Fiber-Optic Delay Line

Electrical Characteristics

Parameter	5017C	5017G	Units
Upper Band Edge Frequency	15	15	GHz
Lower Band Edge Frequency	0.1	0.1	GHz
Amplitude Flatness	5	5	dB
Insertion Loss, 8 μ -sec ¹	28		dB
Insertion Loss, 110 μ -sec ¹		50	dB
Max Delay	8	110	μ -Sec
Input RF Return Loss, max 0.1 - 10 GHz	-7.0	-7.0	dB
10 - 15 GHz	-4.0	-4.0	dB
Output RF Return Loss, max 0.1 - 10 GHz	-9.0	-9.0	dB
10 - 15 GHz	-6.0	-6.0	dB
Impedance	50	50	Ohm
Input 1 dB Compression, min	+20	+20	dBm
Input Third Order Intercept, min 0.1 GHz - 4 GHz	+30	+30	dBm
4 GHz - 15GHz	+25	+25	dBm
Noise Figure, max. 0.1 GHz - 4 GHz	49	59	dB
4 GHz - 10 GHz	54	64	dB
10 GHz - 15 GHz	64	74	dB
Delay Accuracy	± 1.0	± 1.0	%

1: Shoter delays will have lower loss

OUTLINE DRAWING

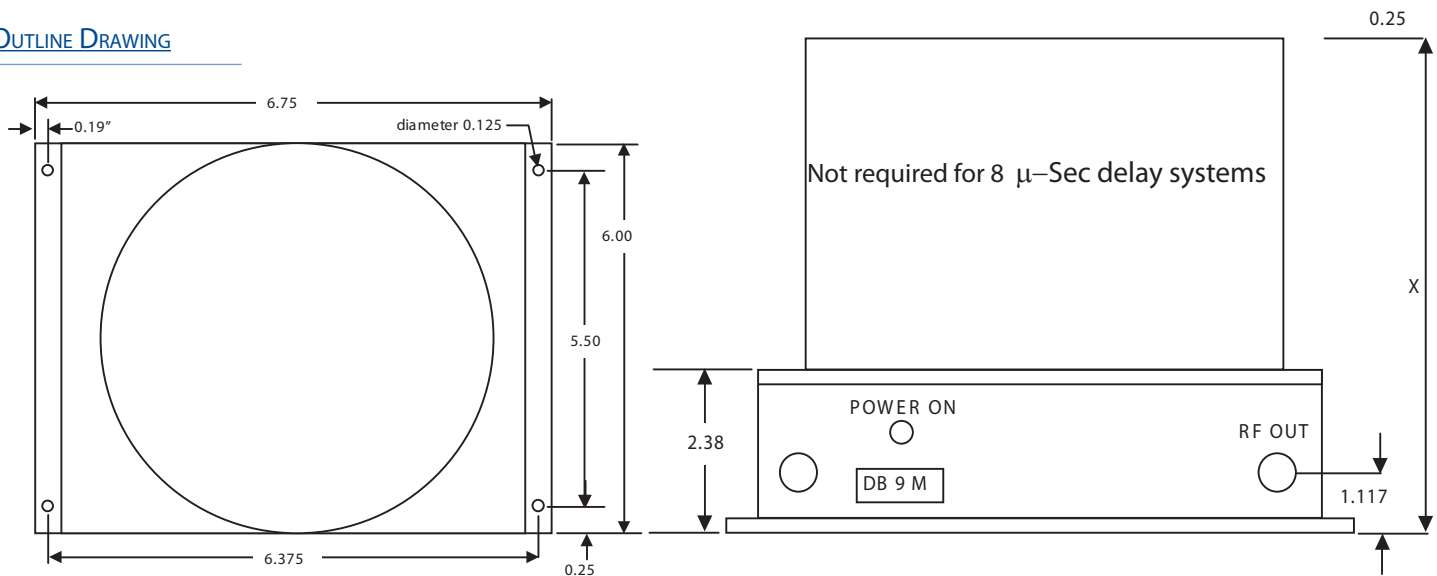

Dimension "X"

- 8 μ -Sec Max: 2.38 inches
- 35 μ -Sec Max: 4.38 inches
- 60 μ -Sec Max: 5.38 inches
- 80 μ -Sec Max: 6.38 inches
- 110 μ -Sec Max: 7.88 inches

Rev: December 15, 2010