

Optiva OTS-2: Ku-Band

RF Fiber Optic Transport System



DATASHEET | JUNE 2013

SATCOM



Applications

- Satcom Ku-Band Antenna Signal Distribution
- Ground Terminal & Intra-Facility Links
- Site Diversity Systems
- Electronic Warfare (EW) Systems
- Broadband Delay Line and Signal Processing Systems

Features / Benefits

- Ku-Band Uplink and Downlink - Eliminates the performance and cost penalty of block up/down conversion
- Low RIN Source Laser - Provides high-dynamic-range of >102 dB Hz^{2/3}
- Microprocessor-Based Transmitter Control for Laser Bias, Modulator Bias & Link Gain - Provides consistent high performance operation and allows for modulator low-bias operation and SFDR >102 dB Hz^{2/3}
- SNMP V.1 and RS-232 Monitor & Control Interface - Flexible user interface options
- Compatible with EMCORE's Modular Optiva Platform - Allows multiple format and frequency transport in a single chassis
- DWDM Operation - Increases transport capacity without increasing fiber count

Ku-Band RF Fiber Optic Transport System System

The Optiva OTS-2 Ku-Band transmitter and receiver are ideal to construct downlink 10.700 to 12.750 GHz and uplink 13.750 to 14.500 GHz transparent fiber optic links for antenna remoting, electronic warfare systems, broadband delay lines, signal processing systems and other high-dynamic-range applications.



Optiva satellite and microwave transmitters and receivers are SNMP compliant. They can be housed in the same chassis and monitored by the same Network Management System (NMS) as Optiva HD video, audio, serial data, and USB extension / distribution cards to provide multiple format and frequency transport in a single flexible platform.

System Design

The Optiva platform includes a wide range fiber **optiva** PLATFORM optic transport products for satellite and microwave communications from 1 MHz to 40 GHz. These units can be used to construct transparent inter- and intra-facility links from 1 meter to >100 km for RF and microwave signal transport, antenna remoting, video transport, electronic warfare systems and other high-dynamic-range applications.

Optiva is a completely modular, hot-swappable platform. Both 19" rack-mount and compact tabletop, or wall-mountable enclosures are available. The 3RU 19" rack-mount, fan-cooled enclosures (Model OT-CC-16 and OT-CC-16F) can support up to 16 insert cards and utilize two dual-redundant, hot-swappable, 100 or 200 watt power supplies. The 1RU 19" rack-mount, fan-cooled enclosure (Model: OT-CC-6-1U) can accommodate 6 insert cards and utilizes two hot-swappable 60 watt power supplies. Compact one-slot (OT-DTCR-1), or two-slot (OT-DTCR-2) enclosures are also available that use an external wall-mount power supply.

Enclosure Options

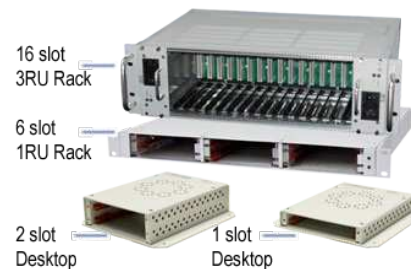

Performance Highlights

Parameter	Min	Typical	Max	Units
Frequency Range	10.70	-	12.750	GHz
	13.750	-	14.500	GHz
RF Input Power	-	-	5* -15^	dBm
Wavelength	-	1550	-	nm
Optical Output Power	9	10	11	dBm
Operating Temperature Range	-10	-	50	°C

*TX: RF amp 15 dB gain, attenuation range 0 to 15 dB
 ^TX: RF amp 35 dB gain, attenuation range 0 to 15 dB

Absolute Maximum Ratings

Stresses in excess of the absolute maximum ratings can cause permanent damage to the device. These are absolute stress ratings only. Functional operation of the device is not implied at these or any other conditions in excess of those given in the operational sections of the datasheet. Exposure to absolute maximum ratings for extended periods can adversely affect device reliability.

Parameter	Symbol	Min	Max	Units
Operating Temperature	T _{OP}	-20	60	°C
Storage Temperature	T _{STG}	-40	85	°C
RF Input	S _{in}	NA	5* -15^	dBm

*TX: RF amp 15 dB gain
 ^TX: RF amp 35 dB gain

Transmitter & Receiver Block Diagram

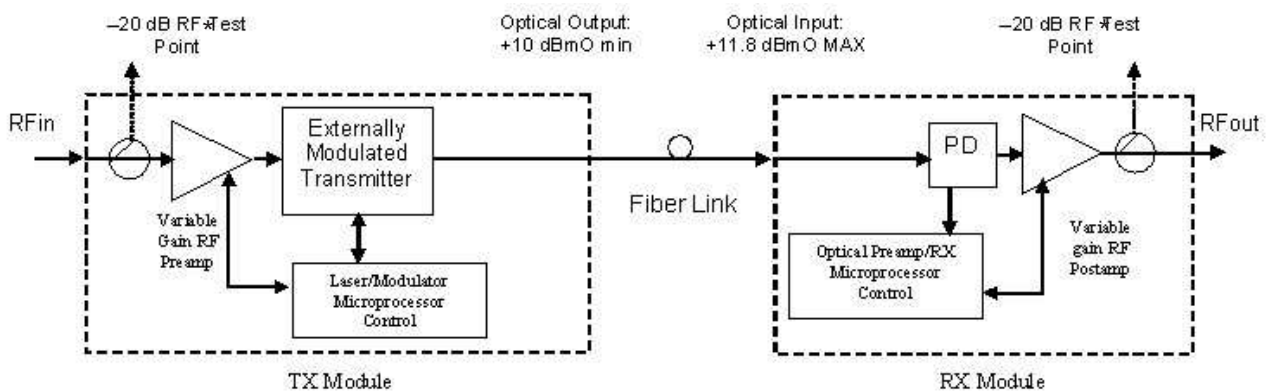

*50 Ω SMA female connectors

Optiva OTS-2: Ku-Band

RF Fiber Optic Transport System



DATASHEET | JUNE 2013

SATCOM

Transmitter & Receiver Optical Characteristics

Parameter	Symbol	Condition	Min	Typical	Max	Units
Wavelength	λ	-	1530	1550	1562	nm
Optical Output Power	P_L	-	9	10	11	dBmo
Connector Return Loss	-	-	40	-	-	dB
Optical Connector Type	-	SC/APC	-	-	-	-
Receiver Optical Input Power	P_{in}	-	-	-	+10	dBmo
Receiver Responsivity	-	-	0.7	-	-	A/W

Note: In order to prevent reflection-induced distortion degradation, the laser should be connected to an optical cable having a return loss of at least 55 dB for discrete reflections and 30 dB for distributed reflections.

Ku-Band Transmitter & Receiver RF Characteristics

Parameter	Condition	Min	Typical	Max	Units
Operational Bandwidth	-	10.700	-	12.750	GHz
	-	13.750	-	14.500	GHz
RF Input Impedance	-	-	50	-	Ω
RF Return Loss	-	-	-	-15	dB
RF Connectors	SMA Female				
RF Test Point Reference Value, Relative to RF input or RF output*	-	-18	-20	-22	dB

*Test point performance beyond the stated frequency range is provided; only the test point reference value tolerance may increase beyond the above stated +/- 1 dB

DC Power Consumption - Max

Module Type	Input Voltage (VDC)	Max Current (@+70°C)
Transmitter	+12	1A
Receiver	+12	750 mA

Environmental Specifications

Parameter	Symbol	Min	Max	Units
Operating Temperature	T_{OP}	-10	50	°C
Operating Humidity, Maximum Non-Condensing	--	--	95%	--
Operating Altitude, Above Sea Level	--	--	6000	ft
Storage Temperature	T_{STG}	-40	70	°C
Storage Humidity, Maximum Non-Condensing	--	--	95%	--
Storage Altitude, Above Sea Level	--	--	50,000	ft

Optiva OTS-2: Ku-Band

RF Fiber Optic Transport System



DATASHEET | JUNE 2013

SATCOM

Link Performance - Ku-Band Downlink

Parameter	Symbol	Condition	Min	Typical	Max	Units
RF Bandwidth	-	-	10.700	-	12.750	GHz
Link Gain (+0 dBm _o RX optical input)*^	G	@ 10.700 GHz	-4	0	-	dB
	G	@ 12.750GHz	-4	0	-	dB
Link Gain (+10 dBm _o RX optical input)*^	G	@ 10.700 GHz	16	20	-	dB
	G	@ 12.750GHz	16	20	-	dB
Noise Figure (+0 dBm _o RX optical input)^	NF	@ 10.700 GHz	12	-	-	dB
	NF	@ 12.750GHz	12	-	-	dB
Noise Figure (+10 dBm _o RX optical input)^	NF	@ 10.700 GHz	7	-	-	dB
	NF	@ 12.750GHz	7	-	-	dB
Input IP3^	IIP3	@ 10.700 GHz	-	-6	-	dBm
	IIP3	@ 12.750GHz	-	-5	-	dBm
Spurious Free Dynamic Range^	SFDR	@ 0 dBm _o RX Optical Input	101	-	-	dB-Hz ^{2/3}
	SFDR	@ +10 dBm _o RX Optical Input	105	-	-	dB-Hz ^{2/3}
Gain Variation	-	Any 36 MHz	-	-	0.5	dB
	-	Any 500 MHz	-	-	1.5	dB

*Receiver RF output will change 2 dB for each 1 dB of RX optical input power level change

^Performance based on OTS-2T/S5 with RF Amp gain of 35 dB, OTS-2R/S5 with RF Amp gain of 15 dB

Link Performance - Ku-Band Uplink:

Parameter	Symbol	Condition	Min	Typical	Max	Units
RF Bandwidth	-	-	13.750	-	14.500	GHz
Link Gain (+0 dBm _o RX optical input)*^	G	@ 13.750 GHz	-6	-2	-	dB
	G	@ 14.500 GHz	-6	-2	-	dB
Link Gain (+10 dBm _o RX optical input)*^	G	@ 13.750 GHz	14	18	-	dB
	G	@ 14.500 GHz	14	18	-	dB
Noise Figure (+0 dBm _o RX optical input)^	NF	@ 13.750 GHz	12	-	-	dB
	NF	@ 14.500 GHz	12	-	-	dB
Noise Figure (+10 dBm _o RX optical input)^	NF	@ 13.750 GHz	7	-	-	dB
	NF	@ 14.500 GHz	7	-	-	dB
Input IP3^	IIP3	@ 13.750 GHz	-	-6	-	dBm
	IIP3	@ 14.500 GHz	-	-5	-	dBm
Spurious Free Dynamic Range^	SFDR	@ 0 dBm _o RX Optical Input	101	-	-	dB-Hz ^{2/3}
	SFDR	@ +10 dBm _o RX Optical Input	105	-	-	dB-Hz ^{2/3}
Gain Variation	-	Any 36 MHz	-	-	0.5	dB
	-	Any 500 MHz	-	-	1.5	dB

*Receiver RF output will change 2 dB for each 1 dB of RX optical input power level change

^Performance based on OTS-2T/S5 with RF Amp gain of 35 dB, OTS-2R/S5 with RF Amp gain of 15 dB

Network Management

All modules are compliant with SNMP v.1 supported through the Optiva NMS card (OPV-CTRL-IC)

Optiva OTS-2: Ku-Band

RF Fiber Optic Transport System



DATASHEET | JUNE 2013

SATCOM

Typical Ku-Band Downlink S21 Frequency Response



Typical Ku-Band Uplink S21 Frequency Response



Optiva OTS-2: Ku-Band

RF Fiber Optic Transport System



DATASHEET | JUNE 2013

SATCOM

Ordering Information: Transmitter

Transmitter

OTS-2T / S5-VVVV-WW-10-XX-12-YY-Z

- When ordering replace "VVV" with one of the Ku-Band Frequency Options
- When ordering replace "WW" with one of the ITU Channel Options
- When ordering replace "XX" with one of the Optical Connector Options
- When ordering replace "YY" with one of the Variable Gain RF Amplifier Options
- When ordering replace "Z" with one of the Enclosure Options

RF Connector	Ku-Band Frequency Options (GHz) "VVV"	ITU Channel Options (THz / nm) "WW"	Optical Power (dBm)	Optical Connector Options "XX"	Optical Output + RF Test Port (dB)	Variable Gain RF Amplifier Options (dB) "YY"	Enclosure Options "Z"
S5 = 50 Ω SMA	1012 = 10.70-12.750 GHz Uplink 1314 = 13.750-14.500 GHz Downlink	Standard: 00 = non-ITU: 1520-1580 nm Optional: 18 = 191.8 THz/1563.05 nm 19 = 191.9 THz/1562.23 nm 20 = 192 THz/1561.42 nm 21 = 192.1 THz/1560.61 nm 22 = 192.2 THz/1559.79 nm 23 = 192.3 THz/1558.98 nm 24 = 192.4 THz/1558.17 nm 25 = 192.5 THz/1557.36 nm 26 = 192.6 THz/1556.56 nm 27 = 192.7 THz/1555.75 nm 28 = 192.8 THz/1554.94 nm 29 = 192.9 THz/1554.13 nm 30 = 193 THz/1553.33 nm 31 = 193.1 THz/1552.52 nm 32 = 193.2 THz/1551.72 nm 33 = 193.3 THz/1550.92 nm 34 = 193.4 THz/1550.12 nm 35 = 193.5 THz/1549.32 nm 36 = 193.6 THz/1548.51 nm 37 = 193.7 THz/1547.72 nm 38 = 193.8 THz/1546.92 nm 39 = 193.9 THz/1546.12 nm 40 = 194 THz/1545.32 nm 41 = 194.1 THz/1544.53 nm 42 = 194.2 THz/1543.73 nm 43 = 194.3 THz/1542.94 nm 44 = 194.4 THz/1542.14 nm 45 = 194.5 THz/1541.35 nm 46 = 194.6 THz/1540.56 nm 47 = 194.7 THz/1539.77 nm 48 = 194.8 THz/1538.98 nm 49 = 194.9 THz/1538.19 nm 50 = 195 THz/1537.4 nm 51 = 195.1 THz/1536.61 nm 52 = 195.2 THz/1535.82 nm 53 = 195.3 THz/1535.04 nm 54 = 195.4 THz/1534.25 nm 55 = 195.5 THz/1533.46 nm 56 = 195.6 THz/1532.68 nm 57 = 195.7 THz/1531.9 nm 58 = 195.8 THz/1531.12 nm 59 = 195.9 THz/1530.33 nm 60 = 196 THz/1529.55 nm 61 = 196.1 THz/1528.77 nm 62 = 196.2 THz/1527.99 nm	10 = +10 Optical Output	Standard: SA = SC / APC Optional: FA = FC / APC EA = E2000 / APC	1 = Single Optical Output + 2 = -20 dB Test Port	15 = 15 dB 35 = 35 dB	1 = Optiva Indoor Rack Mount Installation 2 = Optiva Outdoor MiniHub Installation

Optiva OTS-2: Ku-Band

RF Fiber Optic Transport System



DATASHEET | JUNE 2013

SATCOM

Ordering Information: Receiver

Receiver

OTS-2R / S5-VVVV-10-WW-XX-2-YY-Z

- When ordering replace "VVVV" with one of the Ku-Band Frequency Options
- When ordering replace "WW" with one of the Optical Connector Options
- When ordering replace "XX" with one of the ITU Channel Options
- When ordering replace "YY" with one of the Variable Gain RF Amplifier Options
- When ordering replace "Z" with one of the Enclosure Options

RF Connector	Ku-Band Frequency Options (GHz) "VVVV"	Optical Power (dBm) "YY"	Optical Connector Options "WW"	ITU Filter Options for Improved Optical Isolation in DWDM Systems (THz / nm) "XX"	Test Port (dB)	Variable Gain RF Amplifier Options (dB) "Y"	Enclosure Options "Z"
S5 = 50 Ω SMA	1012 = 10.70-12.750 GHz Uplink 1314 = 13.750-14.500 GHz Downlink	10 = +10 Max Optical Input	Standard: SA = SC / APC Optional: FA = FC / APC EA = E2000 / APC	Standard: 00 = No filter Optional: 18 = 191.8 THz/1563.05 nm 19 = 191.9 THz/1562.23 nm 20 = 192 THz/1561.42 nm 21 = 192.1 THz/1560.61 nm 22 = 192.2 THz/1559.79 nm 23 = 192.3 THz/1558.98 nm 24 = 192.4 THz/1558.17 nm 25 = 192.5 THz/1557.36 nm 26 = 192.6 THz/1556.56 nm 27 = 192.7 THz/1555.75 nm 28 = 192.8 THz/1554.94 nm 29 = 192.9 THz/1554.13 nm 30 = 193 THz/1553.33 nm 31 = 193.1 THz/1552.52 nm 32 = 193.2 THz/1551.72 nm 33 = 193.3 THz/1550.92 nm 34 = 193.4 THz/1550.12 nm 35 = 193.5 THz/1549.32 nm 36 = 193.6 THz/1548.51 nm 37 = 193.7 THz/1547.72 nm 38 = 193.8 THz/1546.92 nm 39 = 193.9 THz/1546.12 nm 40 = 194 THz/1545.32 nm 41 = 194.1 THz/1544.53 nm 42 = 194.2 THz/1543.73 nm 43 = 194.3 THz/1542.94 nm 44 = 194.4 THz/1542.14 nm 45 = 194.5 THz/1541.35 nm 46 = 194.6 THz/1540.56 nm 47 = 194.7 THz/1539.77 nm 48 = 194.8 THz/1538.98 nm 49 = 194.9 THz/1538.19 nm 50 = 195 THz/1537.4 nm 51 = 195.1 THz/1536.61 nm 52 = 195.2 THz/1535.82 nm 53 = 195.3 THz/1535.04 nm 54 = 195.4 THz/1534.25 nm 55 = 195.5 THz/1533.46 nm 56 = 195.6 THz/1532.68 nm 57 = 195.7 THz/1531.9 nm 58 = 195.8 THz/1531.12 nm 59 = 195.9 THz/1530.33 nm 60 = 196 THz/1529.55 nm 61 = 196.1 THz/1528.77 nm 62 = 196.2 THz/1527.99 nm	2 = -20 dB Test Port	15 = 15 dB 35 = 35 dB	1 = Optiva Indoor Rack Mount Installation 2 = Optiva Outdoor MiniHub Installation

Optiva OTS-2: Ku-Band

RF Fiber Optic Transport System



DATASHEET | JUNE 2013

SATCOM

Mechanical Configuration

Each Transmitter and Receiver module occupies two slots in the EMCORE Optiva Chassis.

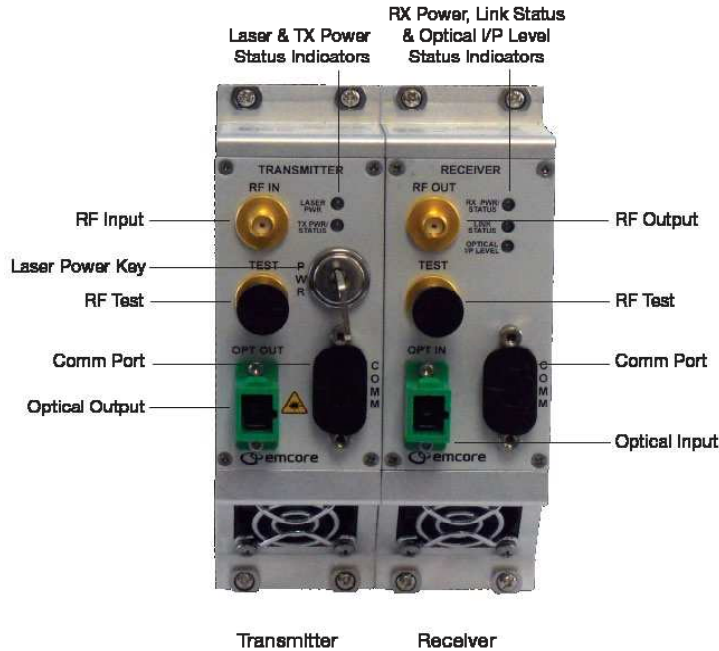

Laser Safety

This product meets the appropriate standard in Title 21 of the Code of Federal Regulations (CFR). FDA/CDRH Class 1M laser product. All versions of this laser are Class 1M laser product, tested according to IEC 60825-1:2007 / EN 60825-1:2007. An additional warning for Class 1M laser products. For diverging beams, this warning shall state that viewing the laser output with certain optical instruments (for example: eye loupes, magnifiers, and microscopes) within a distance of 100 mm may pose an eye hazard. For collimated beams, this warning shall state that viewing the laser output with certain instruments designed for use at a distance (for example: telescopes and binoculars) may pose an eye hazard.

Wavelength = 1.3/1.5 μ m.

Maximum power = 30 mW.

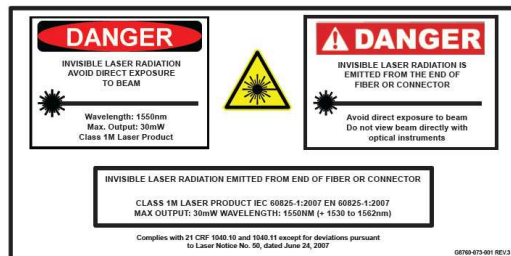

*Caution - Use of controls or adjustments or performance of procedures other than those specified herein may result in hazardous radiation exposure.

*IEC is a registered trademark of the International Electrotechnical Commission.