

# openGear® OPG-1L 50 MHz – 2.3 GHz RF Fiber Optic Link

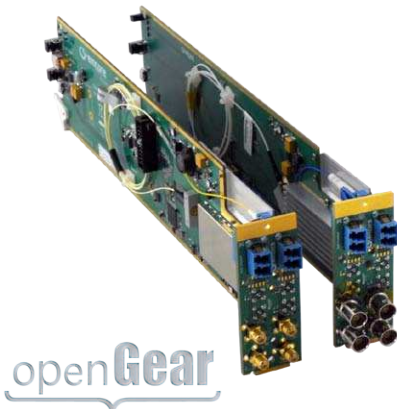

DATASHEET | OCTOBER 2013

SATCOM



EMCORE's openGear® OPG-1L RF Fiber Optic Links are optimized to perform in the 50 MHz to 2.3 GHz frequency range providing transparent signal transport for satellite antenna applications on an open architecture platform.



The OPG-1L transmitter and receiver modules may be housed in the same chassis as EMCORE'S openGear® HD video, audio, serial data and USB extension / distribution cards, allowing full monitoring and control of each module via the DashBoard Network Management System (NMS).

## System Design

The OPG-1L was designed to be fully compatible with the openGear® standard for terminal equipment or cable headend design. This means that when you install an openGear® enclosure, you can then purchase additional insert cards from different manufacturers to be used in the same enclosure. The standard enclosure is a 19" rack-mount frame that can hold up to 20 insert cards. A separate module handles the management and control systems, and allows for local or remote interfaces. Each enclosure utilizes 2 RU of rack space, maximizing the overall usage of the equipment rack.



The OPG-1L's Rear Interface Modules may be pre-installed with its cabling, without corresponding PCBA cards. This allows the user to anticipate future expansion needs without significantly increasing the initial investment, and without having to access the rear panel and cabling once installed. The user simply purchases corresponding PCBA cards on an as-needed basis then slides them into place from the front of the frame, effortlessly locking them into the Rear Interface Module.

## Features

- 50 MHz to 2.3 GHz Optimized for IF- and L-Band Video Signals
- Supports 30 km Links\*\*
- Optically-Isolated DFB Lasers Enable High-Dynamic-Range Links
- 25 dB Tx and Rx Adjustable Gain Range
- Peak Optimizer for Quick and Easy Set-Up
- SmartGain for Enhanced AGC Performance
- 50 & 75 Ohm BNC or 50 Ohm SMA
- Blind Mate RF Coax to Support Rear Plug-in Access
- SC/APC and LC/APC Optical Connectors
- Tx & Rx RF Power Monitors Via LED, SMA, Dashboard and SNMP
- Dashboard and SNMP Monitoring and Control
- LNB Power Capable
- Tx and Rx PCBA Card and Module
- 2 RU, 20-Slot openGear® Enclosure
- CE & CSA Certified, RoHS

\*\*For higher optics, please contact us

## Block Diagram

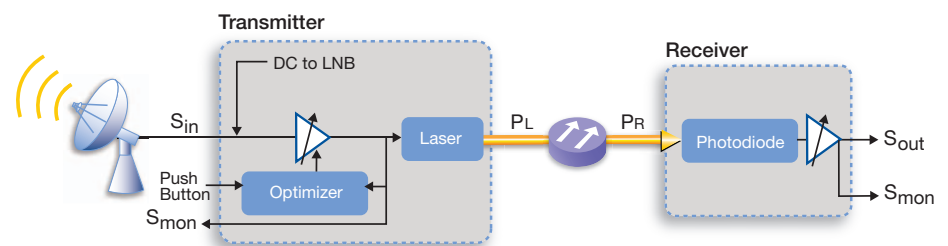

# openGear® OPG-1L 50 MHz – 2.3 GHz RF Fiber Optic Link



DATASHEET | OCTOBER 2013

SATCOM

## Performance Highlights

Parameter	Value	Units		
TX	Wavelength	1310, 1550	nm	
	Optical Output Power	5 ± 2	dBm	
	IF-Band Frequency	50-1000	MHz	
	L-Band Frequency	850-2300	MHz	
	Frequency Response	Any 500 MHz	± 0.75	dB
		Full Band (50-2300 MHz)	± 1.5	dB
		Input Return Loss (minimum)	10	dB
	Total Front-End RF Gain <sup>1</sup> (at minimum attenuation setting)	25 ± 2	dB	
	Attenuation Adjustment Range	30	dB	
	Spurs Free Dynamic Range <sup>2</sup>	98	dB-Hz <sup>2/3</sup>	
	Noise Figure (at maximum gain, 25°C)	23	dB	
	Input IP3 (at maximum gain, 25°C)	-4	dBm	
	Total RF Power Into Laser	2 ± 2dB	dBm	
RX	Output Return Loss (Minimum)	10	dB	
	Total Front-End RF Gain <sup>1</sup> (at minimum attenuation setting)	20 (dual output) 25 (single output)	dB	
	Attenuation Adjustment Range	15	dB	
	Output IP3 (at maximum gain, 25°C)	20 (dual output) 25 (single output)	dBm	

1. Link RF Gain<sub>dB</sub> = TG + RG - 2\*Fiber Loss<sub>dB</sub>

2. SFDR = 2/3\*(IP3 + 174 - NF).

## Mechanical Characteristics

Parameter	Value <sup>1</sup>	Units
PCBA Card Dimension	12.8 L x 3.0 H x 0.681 W	in
	32.5 L x 7.62 H x 0.173W	cm
Rear Interface Module Dimension	1.362 L x 3.365 H x 1.31 W	in
	3.46 L x 8.55 H x 3.33 W	cm

1. Defined per openGear Development Guide by Ross: 8200DR-001-02, 8200DR-001-03

## Electrical Characteristics

Parameter	Value	Units	
TX	Power Requirement	12	W
	Input Voltage (@ 1 A Max)	12 +/- 0.5	VDC
	LNB Voltage (at RF input port, 350 mA max)	17 +/- 1.0	VDC
	DC Current (@ +12 V with LNB Off)	350 +/- 50	mA
	RX	Input Voltage (@ 1 A Max)	12 +/- 0.5
DC Current (@ +12 V)		250 +/- 50	mA

## Frame Options



OPG-8321



OG3-FR

## OPG-1L

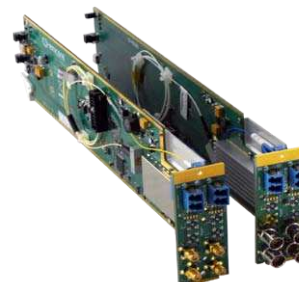

PCBA Cards with Rear Interface Modules



PCBA Cards

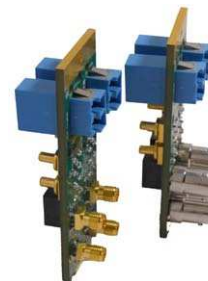

Rear Interface Modules

# openGear® OPG-1L 50 MHz – 2.3 GHz RF Fiber Optic Link



DATASHEET | OCTOBER 2013

SATCOM

## Card Compatibility to openGear® Frames



OPG-8321

OG3-FR

PCBA: OPG-UT-YY03-ZZ  
RIM: OPG-B (BNC Connector)  
or OPG-S (SMA Connector)



OG3-FR

PCBA: OPG-UR-V-ZZ  
RIM: OPG-B (BNC Connector)  
or OPG-S (SMA Connector)

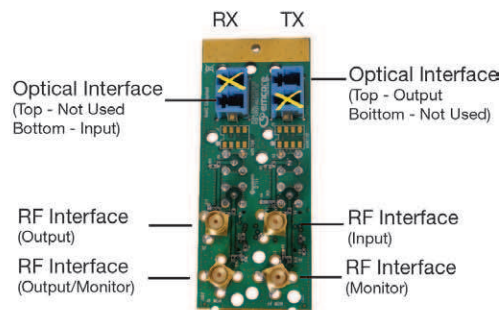
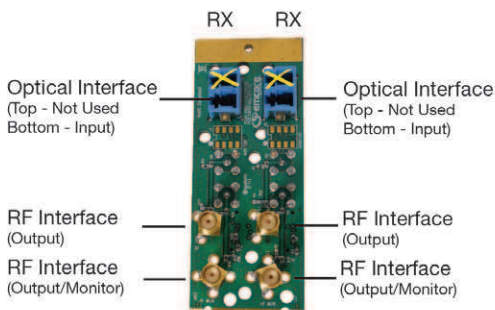
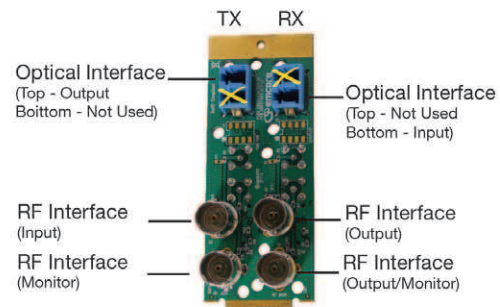
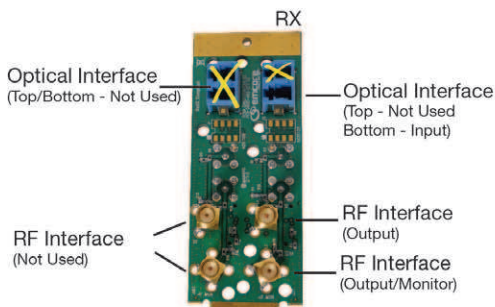
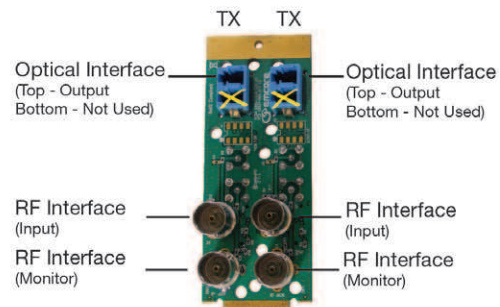
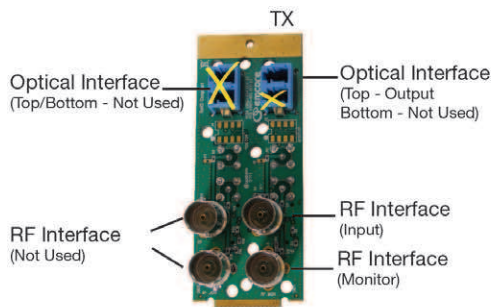

# openGear® OPG-1L 50 MHz – 2.3 GHz RF Fiber Optic Link



DATASHEET | OCTOBER 2013

SATCOM

## Ordering Information PCBA Card

Transmitter <sup>1</sup>	Receiver
OPG-UT-YY05-ZZ	OPG-UR-V-ZZ

Note 1. When installing transmitter cards in the OG3-FR frame, remove the pre-installed LNB blocker plug from the PCBA card but leave as-is for the OPG-8321 frame to prevent the frame's DC-power alarm from activating.

When ordering replace "U" with one of the Frequency Band Options  
 When ordering replace "V" with one of the RX Only: RF Interface Options  
 When ordering replace "YY" with one of the Wavelength Options\*\*  
 When ordering replace "ZZ" with one of the Optical Connector Options

Frequency Band Options "U"	Frequency Band (MHz)	RX Only: RF Interface Options "V"	Wavelength Options (nm) "YY"	Output Power (dBm)	Optical Connector Options "ZZ"
I = IF-Band	50-1000	1 = Output+Monitor 2 = Dual Outputs	13 = 1310, 55 = 1550	05 = +5	LA = LC-APC, SA = SC-APC (OG3-FR only)
L = L-Band	850-2300	1 = Output+Monitor 2 = Dual Outputs	13 = 1310, 55 = 1550	05 = +5	LA = LC-APC, SA = SC-APC (OG3-FR only)

## Ordering Information for Rear Interface Module (RIM)

Transmitter/Receiver	RF Connector Options "W"	RF Connector Impedance Options (ohm) "X"
OPG-WX	B = BNC, S = SMA	5 = 50, 7 = 75 (BNC only)

When ordering replace "W" with one of the RF Connector Options

## Laser Safety

This product meets the appropriate standard in Title 21 of the Code of Federal Regulations (CFR). FDA/CDRH Class 1M laser product. This device has been classified with the FDA/CDRH under accession number 0220191. All versions of this laser are Class 1M laser product, tested according to IEC 60825-1:2007 / EN 60825-1:2007. An additional warning for Class 1M laser products. For diverging beams, this warning shall state that viewing the laser output with certain optical instruments (for example: eye loupes, magnifiers, and microscopes) within a distance of 100 mm may pose an eye hazard. For collimated beams, this warning shall state that viewing the laser output with certain instruments designed for use at a distance (for example: telescopes and binoculars) may pose an eye hazard.

Wavelength = 1.3/1.5  $\mu$ m.

Maximum power = 30 mW.



\*Caution - Use of controls or adjustments or performance of procedures other than those specified herein may result in hazardous radiation exposure.

\*IEC is a registered trademark of the International Electrotechnical Commission.

