

YP3040 Pan-Tilt Motor

Operator-controlled field of view adjustment.



- > Pan-tilt functionality for fixed cameras
- > Operator controlled movement
- > IP66-rated protection
- > For wall mounting
- > Easy installation

YP3040 Pan-Tilt Motor is an optional accessory for Axis fixed network cameras with pan-tilt support. It is ideal for use where a cost effective solution for fine adjustments to a camera's field of view is needed.

YP3040 Pan-Tilt Motor adds pan-tilt functionality to Axis fixed network cameras with pan-tilt support. The camera is connected directly to the Pan-Tilt Motor and can be panned and tilted easily by an operator.

YP3040 Pan-Tilt Motor is easy to install. It is pre-configured for use with AXIS Q1755-E Network Camera, AXIS Q1910-E or AXIS Q1921-E Thermal Network Cameras.

YP3040 Pan-Tilt Motor can be used both indoors and outdoors. It is IP66-rated and recommended for use with AXIS T92A20, AXIS T92E05 and AXIS T92E20 Housings. The Pan-Tilt Motor is recommended for wall mounting with an optional YP3040 Wall Bracket. The recommended power supply is AXIS PS24 Mains Adaptor.



Technical specifications – YP3040 Pan-Tilt Motor

General	
Pan/Tilt	Pan range 0° to 355° Tilt range 10° to -80° Pan speed 7.5°/s Tilt speed 6°/s Designed for operator control
Protocol	Pelco-D
Ports	One RS-485 port
Input voltage	24 V AC 50/60 Hz AXIS PS24 Mains Adaptor recommended
Power consumption	30 W
Construction/material	Aluminum alloy
Operating temperature	-20 °C to 65 °C (-4 °F to 149 °F)
Protection class	IP66-rated (indoor and outdoor use)
Load	Torque 1.5 N m (1.1 ft. lb) Top load, maximum 8 kg (17.6 lb)
Mounting	For wall mounting
Weight	4.2 kg (9 lb)
Dimensions	288 x 165 x 188.5 mm (11" x 6" x 7")
Supported cameras	AXIS Q1755/-E Network Cameras, AXIS Q1910/-E and AXIS Q1921/-E Thermal Network Cameras
Included accessories	Mounting kit, Drill template, Installation guide
Recommended accessories	YP3040 Wall Bracket, AXIS T92A20 Housing, AXIS T92E05 Housing, AXIS T92E20 Housing, AXIS PS24 Mains Adaptor
Optional accessories	AXIS T8130 Video Surveillance Control Board

More information is available at www.axis.com

Dimensions mm (inch)

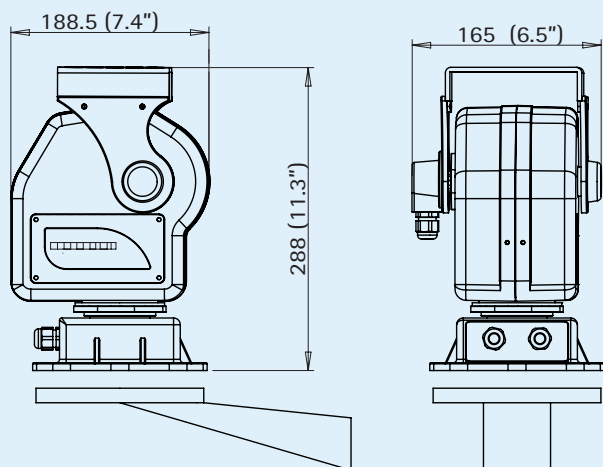

Accessories

YP3040 Wall Bracket



Axis housings



AXIS T8130 Video Surveillance Control Board



AXIS PS24 Mains Adaptor

