

AXIS P12 Network Camera Series

Miniature HDTV cameras for exceptionally discreet surveillance.



- > Functional and extremely discreet design
- > Easy and flexible installation
- > HDTV 720p
- > Edge storage
- > Multiple H.264 streams
- > Power over Ethernet

AXIS P12 Network Camera Series offers small-sized, high-performance cameras for exceptionally discreet indoor and outdoor surveillance. These cameras are perfect for covert installations or where a discreet and compact surveillance solution is required.

AXIS P12 Network Cameras is a series of uniquely designed cameras for exceptionally discreet surveillance. The series comprises three models; two pinhole models, AXIS P1204 and AXIS P1214, which are ideal for indoor installations, and AXIS P1214-E, which is an IP66-rated model that can be installed both indoors and outdoors.

The cameras provide crystal-clear HDTV 720p image quality at full frame rate. AXIS P12 cameras deliver multiple, individually configurable video streams in H.264 compression, which greatly optimizes bandwidth and storage needs without compromising image quality.

The form factor and small size offer excessive flexibility. The sensor unit and main unit are connected by an 8 meter (26ft.) cable, providing flexibility to place the sensor unit in one place and the main unit elsewhere.

AXIS P12 cameras offer powerful event management capabilities with intelligent video features such as tampering alarm and motion detection, in addition to AXIS Camera Application platform.

The cameras can be powered either over Ethernet, or by external power supply. Furthermore, the cameras include support for edge storage with the built-in microSD/microSDHC memory card slot.



Miniature HDTV cameras for discreet indoor and outdoor surveillance

AXIS P12 Network Cameras are flexible and easy to install on walls, ceilings or for integration into very limited spaces.

Unique design concept

With their functional, discreet design and small form factor, AXIS P12 cameras enable easy integration into very limited spaces. AXIS P12 Series is ideal for discreet and covert surveillance in stores, architectural buildings, hotels, offices, banks and ATMs.

Easy installation

The innovative design concept of AXIS P12 Series comprises a main unit, and a separate sensor unit, enabling them to be mounted up to 8 meters (26ft.) apart. The separate sensor unit with a lens and image sensor, offers great flexibility to blend into a wide range of environments, at the same time keeping the cameras protected from tampering.



Mounting options

AXIS P12 Series offers a wide range of mounting options for indoor and outdoor installations. The cameras include various mounting accessories enabling quick and easy installation. The unique form factor and small size of the sensor unit, enables flush mounting at places where a concealed application is required.



Outdoor covert surveillance

AXIS P1214-E is an IP66 and NEMA 4X -rated model, which ensures protection against dust, rain, snow, ice and corrosion. It can operate in temperatures from -20 °C to 50 °C (-4 °F to 122 °F). The supplied housing makes the camera suitable for discreet wall or ceiling mount, allowing an overview without being intrusive. The camera is designed for both indoor and outdoor applications and is ideal for door entrances and ATMs.



Mounting Accessories – AXIS P12 Network Cameras

AXIS P1204 Network Camera



AXIS P1204 can be mounted flat or angled on any surface, using the angled fastening bracket. The camera can also be mounted covertly behind a thin metal sheet in a doorway or an ATM.

AXIS P1214 Network Camera



AXIS P1214 can be mounted behind any wall, with just a small opening for the lens, or with the whole lens protruding from the wall.

AXIS P1214-E Network Camera



AXIS P1214-E which is an IP66-rated model, offers the same mounting options as AXIS P1214. The camera can also be mounted in the supplied housing, suited for both indoor and outdoor applications.

AXIS P1204 Network Camera with included mounting accessories

Sensor unit

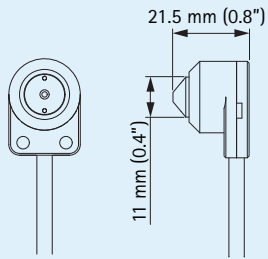

Cover

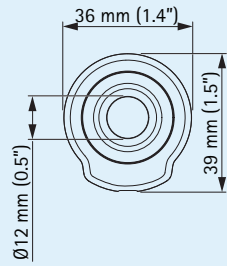

Angled mounting bracket

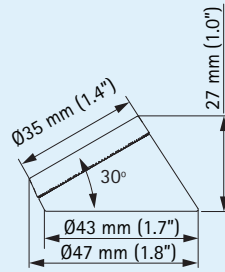

Straight mounting bracket

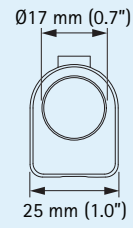

AXIS P1214 Network Camera with included mounting accessories

Sensor unit

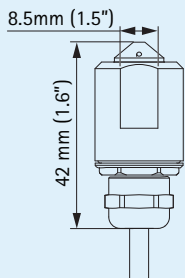
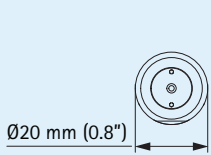

Mounting bracket

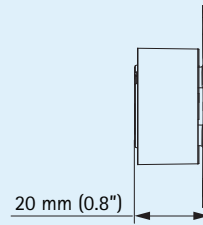
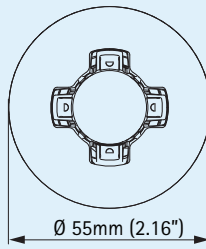

AXIS P1214-E Network Camera with included mounting accessories

Sensor unit

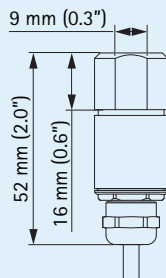
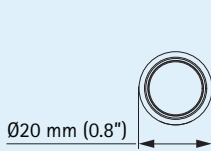

Mounting bracket

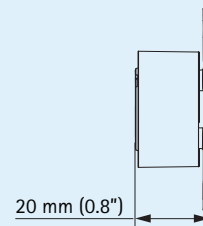
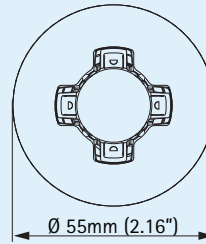

Outdoor housing

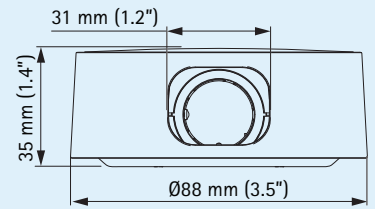

Main unit (all models)

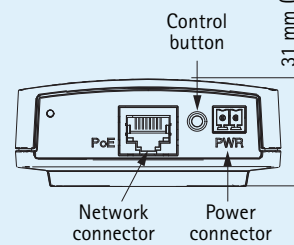
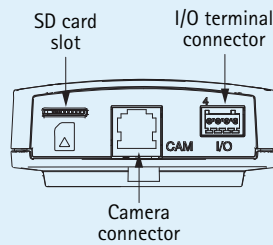
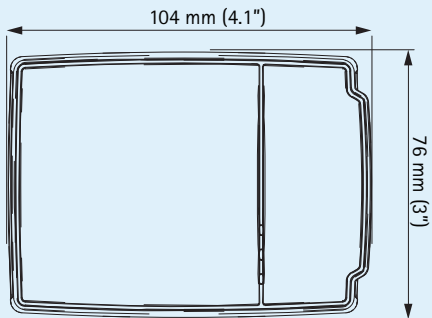

31 mm (1.2")

Mounting rail

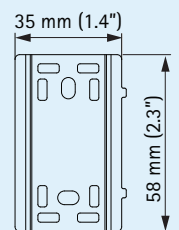

Technical specifications – AXIS P12 Network Camera Series

Camera		System integration	
Models	AXIS P1204: HDTV 720p AXIS P1214: HDTV 720p AXIS P1214-E: HDTV 720p, IP66-rated	Application Programming Interface	Open API for software integration, including VAPIX® and AXIS Camera Application Platform from Axis Communications available at www.axis.com ONVIF, specifications available at www.onvif.org AXIS Video Hosting System (AVHS) with One-Click Camera Connection
Image sensor	1/4" progressive scan RGB CMOS	Intelligent video	Video motion detection, active tampering alarm AXIS Camera Application Platform enabling installation of additional applications
Lens	AXIS P1204/P1214: 3.7 mm: 57° view*, F2.5, fixed iris, fixed focus AXIS P1214-E: 2.8 mm: 81° view*, F2.0, fixed iris, fixed focus *horizontal angle of view	Event triggers	Intelligent video, external inputs, video loss
Light sensitivity	AXIS P1204/P1214: 1.2 - 10000 lux AXIS P1214-E: 1.0 - 10000 lux	Event actions	File upload: FTP, HTTP, network share and email Notification: email, HTTP and TCP External output: video recording to edge storage Pre- and post-alarm video buffering
Shutter time	1/6 s to 1/24500 s	General	
Video		Casing	Main unit: polycarbonate casing AXIS P1204/P1214 sensor unit: metal casing (aluminum) AXIS P1214-E sensor unit: IP66 Nema 4X-rated metal casing (aluminum)
Video compression	H.264 (MPEG-4 Part 10/AVC) Motion JPEG	Memory	256 MB RAM, 128 MB Flash
Resolutions	1280x720 to 320x180	Power	Power over Ethernet IEEE 802.3af Class 2 (max. 6.49W) 8 - 28 V DC max 4.7 W
Frame rate H.264	25 fps with power line frequency 50 Hz 30 fps with power line frequency 60 Hz	Connectors	RJ-45 for 10BASE-T/100BASE-TX PoE RJ-12 for the sensor unit Terminal blocks for power, 1 alarm input and 1 output
Frame rate Motion JPEG	25 fps with power line frequency 50 Hz 30 fps with power line frequency 60 Hz	Edge storage	MicroSD/microSDHC/microSDXC slot supporting memory card up to 64 GB (card not included) Support for recording to network share (network-attached storage or file server)
Video streaming	Multiple, individually configurable streams in H.264 and Motion JPEG Controllable frame rate and bandwidth VBR/CBR H.264	Operating conditions	-20 °C to 50 °C (-4 °F to 122 °F) Humidity 10 - 85% RH (non-condensing)
Image settings	Compression, color, brightness, sharpness, contrast, white balance, exposure control, exposure zones, backlight compensation, fine tuning of behavior at low light, rotation Text and image overlay, privacy mask and mirroring of images Axis' Corridor Format	Approvals	EN 55022 Class B, EN 61000-3-2, EN 61000-3-3, EN 61000-6-1, EN 55024, FCC Part 15 Subpart B Class B, ICES-003 Class B, VCCI Class B, C-tick AS/NZS CISPR 22, KCC Class B, EN/IEC 60950-1, IEC 60068-2-6 (Vibration) Class 4M4, IEC 60068-2-27 (shock) Class 4M3, IEC 60068-2-1, IEC 60068-2-2, 60068-2-78 Class 3K3 AXIS P1214-E sensor unit: EN/IEC 60950-22, IEC 60529 IP66, NEMA 250 Type 4X, IEC 60068-2-78 Class 4K3, IEC 60068-2-14, IEC 60068-2-30
Network		Weight	Main unit: 109 g (0.24 lb.) AXIS P1204 sensor unit: 222 g (0.49 lb.) AXIS P1214 sensor unit: 238 g (0.52 lb.) AXIS P1214-E sensor unit: 248 g (0.55 lb.)
Security	Password protection, IP address filtering, HTTPS encryption*, IEEE 802.1X network access control*, digest authentication, user access log	Included accessories	Mounting kit, Installation Guide, Axis Warranty Document, AVHS Authentication key, Installation and Management Software CD, Windows decoder 1-user license
Supported protocols	IPv4/v6, HTTP, HTTPS*, SSL/TLS*, QoS Layer 3 DiffServ, FTP, CIFS/SMB, SMTP, Bonjour, UPnP™, SNMPv1/v2c/v3 (MIB-II), DNS, DynDNS, NTP, RTSP, RTP, TCP, UDP, IGMP, RTCP, ICMP, DHCP, ARP, SOCKS		

* This product includes software developed by the Open SSL Project for use in the Open SSL Tool kit (www.openssl.org)

More information is available at www.axis.com

Optional Accessories – AXIS P12 Network Camera Series

Optional accessories for indoor models

AXIS T8414 Installation Display



AXIS T8120 15W Midspan 1-Port



AXIS P7701 Video Decoder



AXIS P8221 Network I/O Audio Module



Video management software

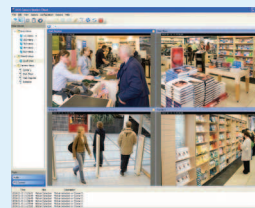

AXIS Camera Companion (included),
AXIS Camera Station and video management software from Axis' Application Development Partners (not included). See www.axis.com/products/video/software/