

# EA, ES, EC Series



## AC/DC

### 20 Watts

Single/Dual Outputs

- High performance design
- Chassis or PC mount
- Continuous short circuit protection
- Isolation to 2500 Vac

## Specifications

### INPUT

Voltage and Frequency

Standard	105 to 125 Vac - 50 to 440 Hz
Suffix I	200 to 252 Vac - 50 to 60 Hz
Suffix N	90 to 110 Vac - 50 to 60 Hz
Suffix K	200 to 252 Vac - 50 to 60 Hz
Suffix K2	105 to 125/210 to 250 Vac

### OUTPUT

Voltage Tolerance	± 1%
Regulation: Line/Load	.015% / .015%
Ripple and Noise (PARD)	7mV RMS
Short Circuit Protection	Power foldback
Temperature Coefficient	0.02% / °C

### GENERAL

I/O Isolation	1500 Vac
Suffix I	2500 Vac

### ENVIRONMENTAL

Operating Temperature	-25°C to +71°C No Derating
Storage Temperature	-25°C to +85°C
Cooling	Free-air Convection

All specifications are typical at nominal line and full load at 25°C unless otherwise noted and are subject to change without notice.

The EA, ES and EC Series of line operated power supplies features near constant efficiency over the entire rated input voltage range. These electrically identical families employ a highly efficient, closed loop ripple regulation circuit, which contains a low pass filter. Each stage, transformer, filter and regulator is engineered for maximum efficiency. This combination provides cooler operation; higher overall system reliability and greater line transient immunity to 60 dB, all to a degree unmatched by conventional power supply designs. Excellent thermal management permits full power output over the full operation range to +71° with no derating.

The EA and ES Series are plug-in modules offering a choice of two industry-standard pin-outs. The EC Series is a chassis-mount with a top-mounted, five-terminal barrier strip for power entry/exit.



**SEMICONDUCTOR  
CIRCUITS, INC.**

toll-free 888.438.3232 toll-free 888.GET.DCDC

# EA, ES and EC Series Ordering Information

Output Voltage	Output Current	AC Pin Spacing Inches (mm)	Fig.	Model Number
5 Vdc	1500mA	2.0 (51)	1-B	ES11-150
5 Vdc	1500mA	2.2 (56)	1-B	EA11-150
5 Vdc	1500mA	--	2-C	EC11-150
5Vdc	3000mA	2.0 (51)	1-C	ES11-300
5Vdc	3000mA	2.2(56)	1-C	EA11-300
5Vdc	3000mA	--	2-D	EC11-300
5Vdc	4000mA	2.0 (51)	1-D	ES11-400
5Vdc	4000mA	2.2(56)	1-D	EA11-400
5Vdc	4000mA	--	2-D	EC11-400
12Vdc	800mA	2.0 (51)	1-B	ES12-080
12Vdc	800mA	2.2 (56)	1-B	EA12-080
12Vdc	800mA	--	2-C	EC12-080
12Vdc	1500mA	2.0 (51)	1-D	ES12-150
12Vdc	1500mA	2.2 (56)	1-D	EA12-150
12Vdc	1500mA	--	2-D	EC12-150
15Vdc	650mA	2.0(51)	1-B	ES13-065
15Vdc	650mA	2.2(56)	1-B	EA13-065
15Vdc	650mA	--	2-C	EC13-065
24Vdc	400mA	2.0 (51)	1-B	ES17-040
24Vdc	400mA	2.2 (56)	1-B	EA17-040
24Vdc	400mA	--	2-C	EC17-040
±12Vdc	±500mA	2.0(51)	1-D	ES22-100
±12Vdc	±500mA	2.2 (56)	1-D	EA22-100
±12Vdc	±500mA	--	2-D	EC22-100
±15Vdc	±500mA	2.0 (51)	1-D	ES23-100
±15Vdc	±500mA	2.2 (56)	1-D	EA23-100
±15Vdc	±500mA	--	2-D	EC23-100

## Dimensions and Connections

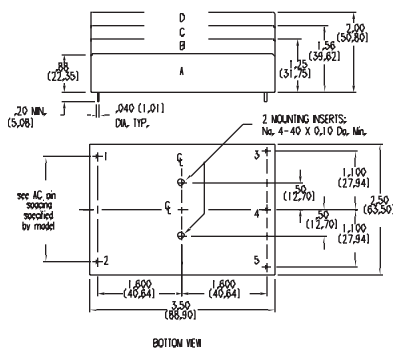

FIG. 1  
Dual Outputs (Fig. 1)  
2.0" and 2.2" AC Pin Spacing

1. VAC in high
2. VAC in neutral
3. -Output
4. Common
5. +Output

### PIN CONNECTIONS Single Output (Fig. 1) 2.0" AC Pin Spacing

1. VAC in high
2. VAC in neutral
3. Common
4. No connect
5. +Output

### PIN CONNECTIONS Single Output (Fig. 1) 2.2" AC Pin Spacing

1. VAC in high
2. VAC in neutral
3. No connect
4. Common
5. +Output

### TERM CONNECTIONS Single Output (Fig. 2)

1. VAC in high
2. VAC in neutral
3. +Output
4. No connect
5. Common

### TERM CONNECTIONS Dual Outputs (Fig. 2)

1. VAC in high
2. VAC in neutral
3. +Output
4. Common
5. -Output

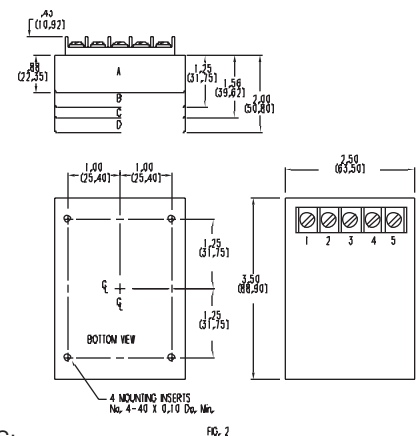

FIG. 2

- NOTES:
1. Ripple measured with a 3.3 mf tantalum capacitor across each output.

11/01/2001