

QQA Series



DC/DC

6 Watts

Single/Dual Outputs

- Surface mount technology
- MOSFET design
- 4:1 ultra wide input range
- Continuous short circuit protection
- Six-sided shielding

Specifications

INPUT

Voltage Range	4.5 - 5.5Vdc 9 - 36Vdc 20 - 72Vdc
Filtering	All Models

OUTPUT

Voltage Tolerance	± 2%
Ripple and Noise (PARD)	1% pk-pk (typ)
Short Circuit Protection	Continuous Power Cycle
Temperature Coefficient	0.02% / °C

GENERAL

Regulation:	
Line	1.0%
Load	5.0%
Efficiency	75% (typ)
I/O Isolation	500 Vdc
Switching Frequency	100kHz (typ)

ENVIRONMENTAL

Operating Temperature	-25°C to +71°C No Derating
Maximum Case Temp	105°C
Storage Temperature	-25°C to +105°C
Cooling	Free-air Convection

All specifications are typical at nominal line and full load at 25°C unless otherwise noted and are subject to change without notice.

The QQA series features the latest in MOSFET design, state of the art surface mount technology, and offers a 4:1 ultra-wide input range, and efficiencies greater than 80% (typ). Features include continuous short circuit protection, 500 Vdc I/O isolation, and an operating temperature range of -25°C to +71°C with no derating. All models are packaged in a six-sided shielded miniature case measuring only 1.0" x 2.0" x 0.4" high.

Applications

The QQA Series is ideally suited for telecommunications, process control, automatic and portable test equipment.



**SEMICONDUCTOR
CIRCUITS, INC.**

888.438.3232 888.GET.DCDC

QQA Series Ordering Information

Input Voltage Range	Output Voltage	Output Current	Model Number
4.5-5.5 Vdc	5Vdc	1000mA	QQA11-100-05
9-36 Vdc	5 Vdc	1000mA	QQA11-100-18
20-72 Vdc	5 Vdc	1000mA	QQA11-100-48
4.5-5.5 Vdc	9 Vdc	660mA	QQA19-066-05
9-36 Vdc	9 Vdc	660mA	QQA19-066-18
20-72 Vdc	9 Vdc	660mA	QQA19-066-48
4.5-5.5 Vdc	12 Vdc	500mA	QQA12-050-05
9-36 Vdc	12 Vdc	500mA	QQA12-050-18
20-72 Vdc	12 Vdc	500mA	QQA12-050-48
4.5-5.5 Vdc	15 Vdc	400mA	QQA13-040-05
9-36 Vdc	15 Vdc	400mA	QQA13-040-18
20-72 Vdc	15 Vdc	400mA	QQA13-040-48
4.5-5.5 Vdc	±12 Vdc	±250mA	QQA22-050-05
9-36 Vdc	±12 Vdc	±250mA	QQA22-050-18
20-72 Vdc	±12 Vdc	±250mA	QQA22-050-48
4.5-5.5 Vdc	±15Vdc	±200mA	QQA23-040-05
9-36 Vdc	±15 Vdc	±200mA	QQA23-040-18
20-72 Vdc	±15 Vdc	±200mA	QQA23-040-48

Dimensions and Connections

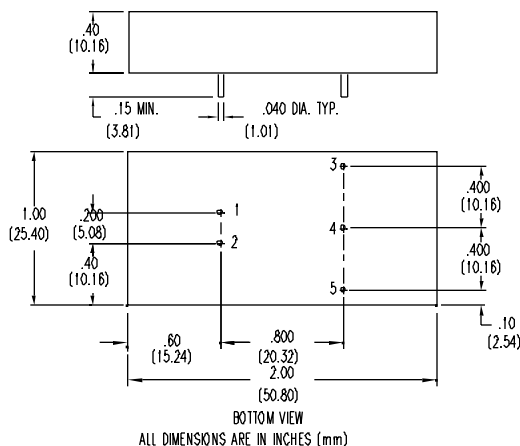

Pins 0.040 (1.0) dia x 0.20 (5.1) lg min.

PIN CONNECTIONS

Single Output

1. +Input
2. -Input
3. + Output
4. No Pin
5. -Output

PIN CONNECTIONS

Dual Outputs

1. +Input
2. -Input
3. +Output
4. Common
5. -Output

NOTES:

1. Ripple measured with a 3.3 mf tantalum capacitor across each output.
2. 20% minimum load required on each output

11/01/2001