

FC Series



DC/DC

.8 to 3 Watts

Dual Outputs

- Ultra low noise
- Pi input filter
- Continuous short circuit protection with auto restart
- Regulated outputs

Specifications

INPUT

Voltage Range	4.5 - 5.5 Vdc 10.8 - 15 Vdc 21.6 - 30 Vdc 42 - 56 Vdc
Reflected Ripple	Less than 1% Vin (max)

OUTPUT

Voltage Tolerance	± 1%
Ripple and Noise	5mV pk-pk
Short Circuit Protection	Current Limit
Temperature Coefficient	0.02% / °C

GENERAL

Regulation:	
Line	0.02%
Load	0.02%
Efficiency	65% (typ)
I/O Isolation	300 Vdc
Switching Frequency	6 to 20khz

ENVIRONMENTAL

Operating Temperature	-25°C to +71°C No Derating
Storage Temperature	-25°C to +105°C
Cooling	Free-air Convection

All specifications are typical at nominal line and full load at 25°C unless otherwise noted and are subject to change without notice.

The FC Series are ultra-low noise, high performance DC/DC converters that are packaged in low profile (0.4 inch high) cases. Essential quality performance features are designed and built-in. A high performance Pi input filter minimizes input reflected ripple, while 5-sided electrostatic shielding and tape-wound toroids, rather than pot cores, minimize radiated EMI. Advanced circuit design techniques reduce conducted output noise in the form of current spikes, to an extremely low level.

Applications

The FC Series converters are ideal for noise-sensitive analog and digital applications having high component density and stringent performance requirements. For ease of use and system reliability, all FC Series models feature I/O isolated outputs which are overcurrent protected by a self-resetting current limit circuit.



SEMICONDUCTOR
CIRCUITS, INC.

888.438.3232 888.GET.DCDC

FC Series Ordering Information

Input Voltage Range	Output Voltage	Output Current	Case	Model Number
4.5-5.5 Vdc	±12 Vdc	±35mA	A	FC22-007-05
10.8-15.0 Vdc	±12 Vdc	±35mA	A	FC22-007-12
21.6-30.0 Vdc	±12 Vdc	±35mA	A	FC22-007-24
42.0-56.0 Vdc	±12 Vdc	±35mA	A	FC22-007-48
4.5-5.5 Vdc	±12 Vdc	±125mA	B	FC22-025-05
10.8-15.0 Vdc	±12 Vdc	±125mA	B	FC22-025-12
21.6-30.0 Vdc	±12 Vdc	±125mA	B	FC22-025-24
42.0-56.0 Vdc	±12 Vdc	±125mA	B	FC22-025-48
4.5-5.5 Vdc	±15 Vdc	±30mA	A	FC23-006-05
10.8-15.0 Vdc	±15 Vdc	±30mA	A	FC23-006-12
21.6-30.0 Vdc	±15 Vdc	±30mA	A	FC23-006-24
42.0-56.0 Vdc	±15 Vdc	±30mA	A	FC23-006-48
4.5-5.5 Vdc	±15 Vdc	±100mA	B	FC23-020-05
10.8-15.0 Vdc	±15 Vdc	±100mA	B	FC23-020-12
21.6-30.0 Vdc	±15 Vdc	±100mA	B	FC23-020-24
42.0-56.0 Vdc	±15 Vdc	±100mA	B	FC23-020-48

Dimensions and Connections

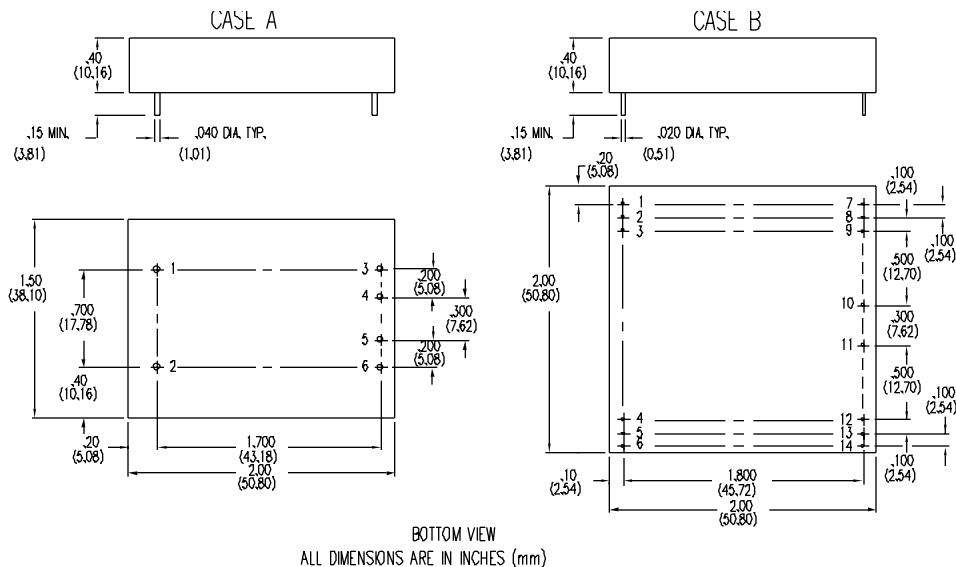

BOTTOM VIEW
ALL DIMENSIONS ARE IN INCHES (mm)

PIN CONNECTIONS

Dual Output	Case A	Case B
+Input	1	1-3
-Input	2	4-6
+Output	3	7-9
Common	4,5	10,11
-Output	6	12-14

NOTES:

- Ripple measured with a 3.3 mf tantalum capacitor across each output.
- Metal case (shield) connected to output common

11/01/2001