

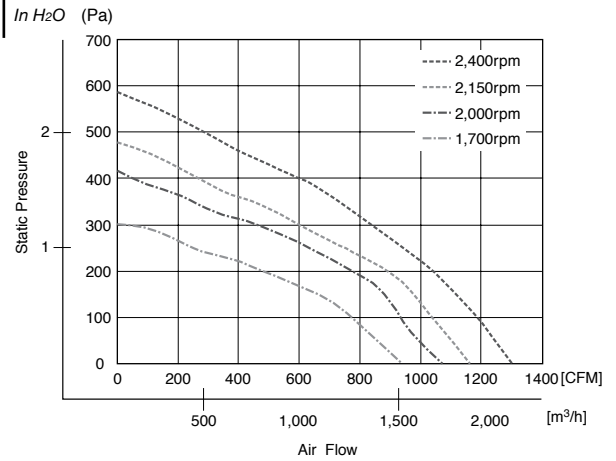

Characteristic Curves



General Specifications

Motor Protection:

Locked Rotor, Reverse Polarity

Insulation Resistance:

10M Ω min measured with 500V DC between all leads shorted together and case

Dielectric Withstand Voltage: AC 700V 1 minute

Allowable Ambient Temperature Range:

-30°C ~ +70°C (Operating)
-40°C ~ +80°C (Storage)

Expected Life

Failure Rate: 10%

40°C 70,000 Hours (L10)

Material

Impeller : Aluminum

Bearing : Ball Bearing

Lead Wire: UL1015, AWG18, +Red, -Black,

Speed Control = Yellow,

Speed Signal = White

Outline

Units: $\frac{\text{inch}}{\text{mm}}$

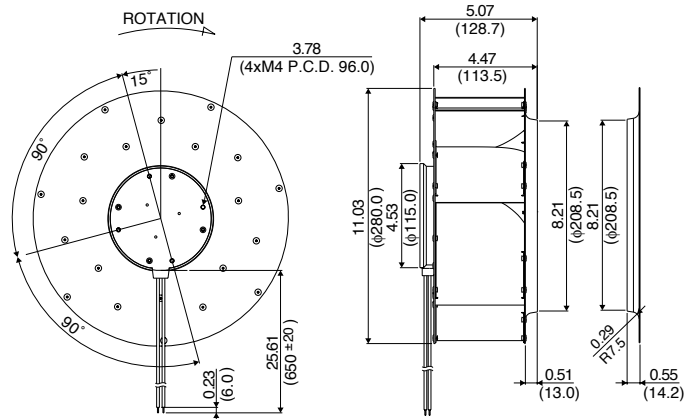

Specifications

MODEL	Rated Voltage	Operating Voltage	Current	Input Power	Speed	Max. Air Flow		Max. Static Pressure		Noise	Mass
	(V)	(V)	(A) ^{*1}	(W) ^{*1}	(min ⁻¹) ^{*1}	CFM ^{*1}	(m ³ /min) ^{*1}	in H ₂ O	(Pa) ^{*1}	(dB) ^{*1}	(g)
F280A1-113-D0720	48	30 ~ 72	4.70	225.6	2400	1304	36.94	2.34	585	81	2100
F280A2-113-D0720	48	30 ~ 72	2.80	134.4	2000	1071	30.33	1.66	416	75	2100
F280A3-113-D0520	24	18 ~ 30	7.30	175.2	2150	1166	33.03	1.91	477	77	2100
F280A4-113-D0510	24	18 ~ 30	3.90	93.6	1700	940	26.62	1.21	302	70	2100

Rotation: Clockwise

*1: Average Values in Free Air and Rated Voltage Condition