

General Specifications

Motor Protection:

Auto Restart/Polarity Protection

Insulation Resistance:

10M Ω or over with a DC500V Megger

Dielectric Withstand Voltage: AC 700V 1s

Allowable Ambient Temperature Range:

-10°C ~ +70°C (Operating)

-40°C ~ +70°C (Storage)

(non-condensing environment)

Expected Life

Failure Rate: 10%

25°C 100,000 Hours (B00/E00)

Material

Casing : Plastic (Black) 94V-0

Impeller : Plastic (Black) 94V-0

Bearing : Ball Bearing

Lead Wire : UL3385, AWG26, +Red, -Black

Panel Cut-Outs

Units: inch (mm)

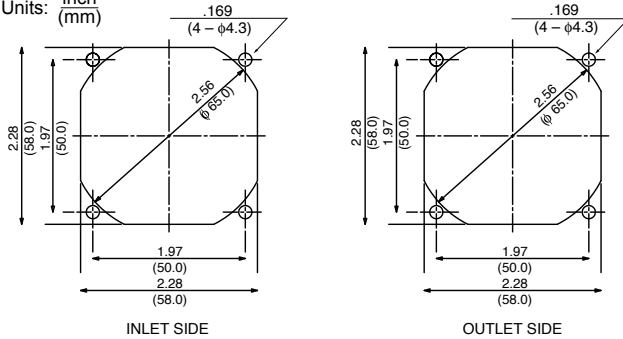

Characteristic Curves

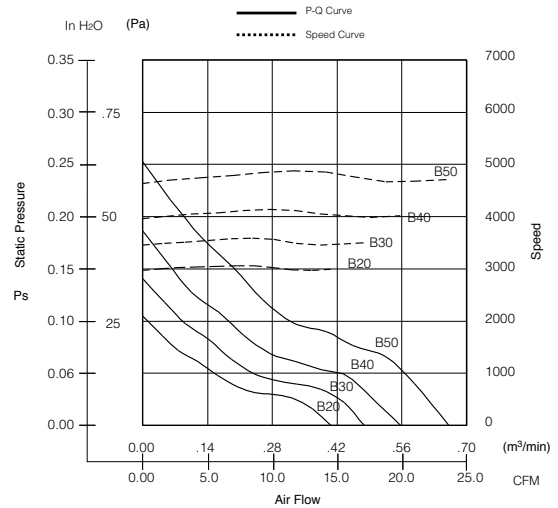

Outline

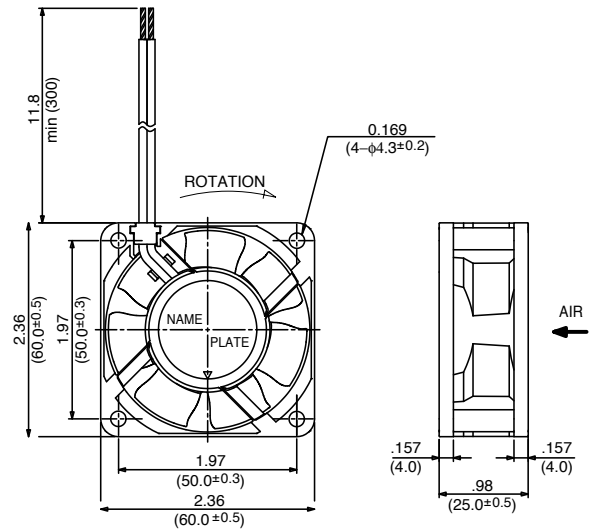

Specifications

MODEL	Product No.	Rated Voltage	Operating Voltage	Current	Input Power	Speed	Max. Air Flow		Max. Static Pressure		Noise	Mass
		(V)	(V)	(A) ^{*1}	(W) ^{*1}	(min ⁻¹) ^{*1}	CFM ^{*1}	(m ³ /min) ^{*1}	in H ₂ O	(Pa) ^{*1}	(dB) ^{*1}	(g)
2410SB-04W-B20	B/EXX	12	6 ~ 13.8	0.06	0.72	3000	14.5	0.41	0.10	26	17.0	56
2410SB-04W-B30	B/EXX	12	6 ~ 13.8	0.08	0.96	3500	16.9	0.48	0.14	35	22.5	56
2410SB-04W-B40	B/EXX	12	6 ~ 13.8	0.10	1.20	4000	19.8	0.56	0.18	46	26.5	56
2410SB-04W-B50	B/EXX	12	6 ~ 13.8	0.15	1.80	4700	23.3	0.66	0.25	63	32.0	56
2410SB-05W-B20	B/EXX	24	12.0 ~ 27.6	0.03	0.72	3000	14.5	0.41	0.10	26	17.0	56
2410SB-05W-B30	B/EXX	24	12.0 ~ 27.6	0.04	0.96	3500	16.9	0.48	0.14	35	22.5	56
2410SB-05W-B40	B/EXX	24	12.0 ~ 27.6	0.06	1.44	4000	19.8	0.56	0.18	46	26.5	56
2410SB-05W-B50	B/EXX	24	12.0 ~ 27.6	0.08	1.92	4700	23.3	0.66	0.25	63	32.0	56

Rotation: Clockwise

Airflow Outlet: Air Out Over Struts

*1: Average Values in Free Air