

Fundamental Mode: 8 MHz - 70 MHz
Third Overtone Mode: 48 MHz - 160 MHz

DESCRIPTION

The CX-1 quartz crystal is a high quality miniature AT cut quality resonator. The CX-1 is hermetically sealed in a rugged, miniature ceramic package, one-fourth the size of an eight-pin mini-DIP. The CX-1 crystal is manufactured using the STATEK-developed photolithographic process, and was designed utilizing the experience acquired by producing millions of crystals for industrial, commercial, military and medical applications.

FEATURES

- Low-profile hermetically-sealed package
- Excellent aging characteristics
- Fundamental or 3rd overtone mode
- High shock resistance
- Full military testing available
- Designed and manufactured in the USA

PACKAGE HANDLING

The CX crystal is hermetically sealed in a ceramic package. Normal handling and soldering precautions for small, low thermal mass parts are adequate when installing or testing CX crystals. CX crystals may be wave soldered, with proper precaution taken to avoid desoldering the leads. A slow machine rate or too high a pre-heat temperature or solder bath temperature can damage the crystals. **Lead to package solder interface temperature should not exceed 175°C, glass lid to package seal rim temperature should not exceed 210°C.** If the seal rim reaches temperatures above the maximum specified, the package may lose its hermeticity resulting in degradation of crystal performance. Mishandling of CX crystals can cause cracking of the glass lid and loss of hermeticity.

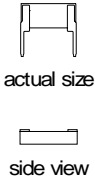
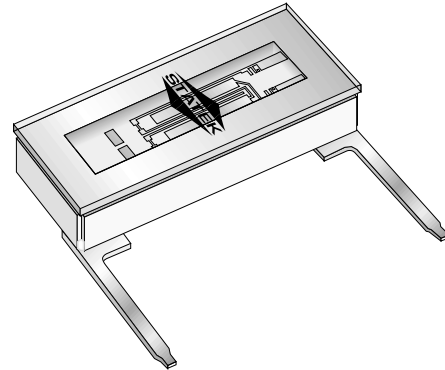

PACKAGE DIMENSIONS

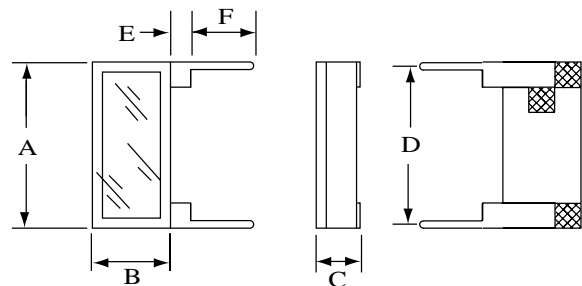

DIM	TYP.		MAX.	
	INCHES	mm	INCHES	mm
A	.315	8.00	.330	8.38
B	.140	3.56	.155	3.94
C	.070	1.78	.080	2.03
D	.300	7.62	.310	7.87
E	.020	0.51	.040	1.02
F	.150	3.81	.160	4.06

Leads 0.013" x 0.018" (0.33 x 0.46 mm) typical.

EQUIVALENT CIRCUIT

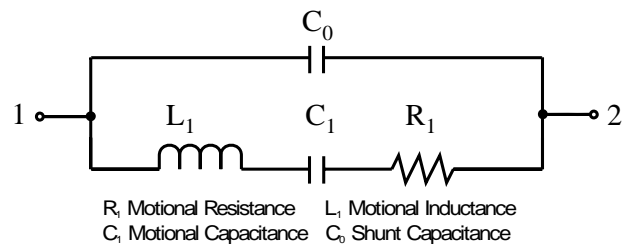

SPECIFICATIONS

Specifications are typical at 25°C unless otherwise noted. Specifications are subject to change without notice.

	10 MHz	32MHz	155.52 MHz
Motional Resistance R_1 (Ω)	50	20	50
Motional Capacitance C_1 (fF)	5.5	7.8	0.5
Quality Factor Q (k)	80	36	41
Shunt Capacitance C_0 (pF)	2.2	2.6	3.2
Calibration Tolerance*	A \pm 0.01% (\pm 100ppm) B \pm 0.1% C \pm 1.0%		
Load Capacitance	20 pF (Unless specified by customer)		
Drive Level	500 μ W MAX.		
Frequency-Temperature Stability**	-10°C to +70°C from \pm 10ppm -40°C to +85°C from \pm 20ppm -55°C to +125°C from \pm 30ppm		
Aging, first year	5ppm MAX.		
Shock, survival***	3,000g, .3 msec., 1/2 sine		
Vibration, survival	20g rms, 10-2,000 Hz random		
Operating Temperature Range	-10°C to +70°C Commercial -40°C to +85°C Industrial -55°C to +125°C Military		
Storage Temperature	-55°C to +125°C		

Note: The characteristics of the frequency temperature stability follow that of AT cut thickness-shear mode*

* Tighter tolerances available as low as \pm 5 ppm

** Does not include calibration tolerance

*** Higher shock version available, refer to data sheet model CX-1HG (10108)

PACKAGING

CX-1-03 - Tray Pack (Standard)

HOW TO ORDER CX-1-03 CRYSTALS

CX-1	-03	32 MHz	(25ppm / 25ppm / 50ppm /)	
"S" if special or custom design. Blank if Std.	O.T.=3 rd O.T. Mode Blank=Fundamental Mode	C=Ceramic Lid Blank=Glass Lid	Frequency	Calibration Tolerance* @25°C (A) (B) (C)
			Frequency Stability over Temp. Range	Total Frequency Tolerance
			Temp. Range: C = Commercial I = Industrial M = Military S = Specify	

*Other calibration fill in ppm.

CIRCUIT DESIGN

A conventional CMOS Pierce Oscillator is shown below. The crystal oscillates at a frequency f_O above the crystal's series-resonant frequency f_S . The crystal is effectively inductive and, in combination with R_A , C_d and C_g in the feedback loop, provides approximately 180° phase shift necessary to obtain oscillation. Typical component values for a Pierce Oscillator using a 16 MHz crystal with a 74HC04 hex inverter are shown below:

Typical Application as Pierce Oscillator
Using 74HC04 CMOS Hex Inverter at 5 VDC

CONVENTIONAL CMOS PIERCE OSCILLATOR CIRCUIT

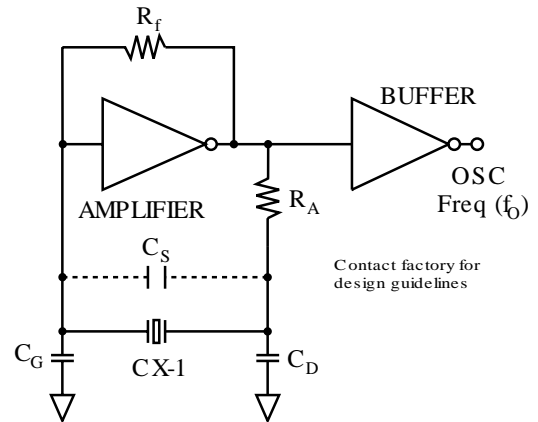

STANDARD FREQUENCIES

10.0 MHz	19.6608 MHz	32.0 MHz
11.0592 MHz	20.0 MHz	35.2512 MHz
12.0 MHz	24.0 MHz	36.0 MHz
14.318 MHz	24.576 MHz	40.0 MHz
16.0 MHz	30.0 MHz	