



CX1SM CRYSTAL

530 kHz to 2.1 MHz

Low Profile, Miniature Surface Mount Quartz Crystal

DESCRIPTION

The CX1SM quartz crystals are leadless devices designed for surface mounting on printed circuit boards or hybrid substrates. They are hermetically sealed in a rugged, miniature ceramic package. The CX1SM crystal is manufactured using the STATEK-developed photolithographic process, and was designed utilizing the experience acquired by producing millions of crystals for industrial, commercial, military and medical applications. Maximum process temperature should not exceed 260°C.

FEATURES

- Extensional mode
- Ideal for use with microprocessors
- Designed for low power applications
- Compatible with hybrid or PC board packaging
- Low aging
- Full military testing available
- Ideal for battery operated applications
- Designed and manufactured in the USA



Glass Lid Shown

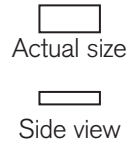

PACKAGE DIMENSIONS

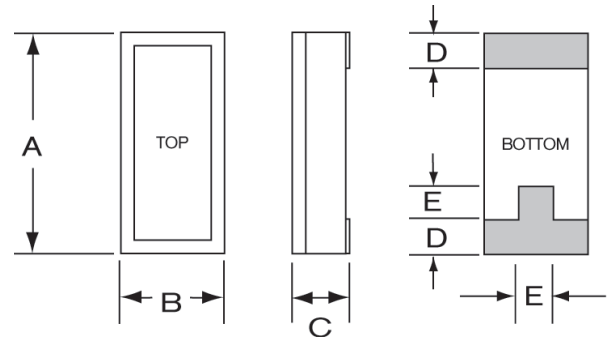

EQUIVALENT CIRCUIT

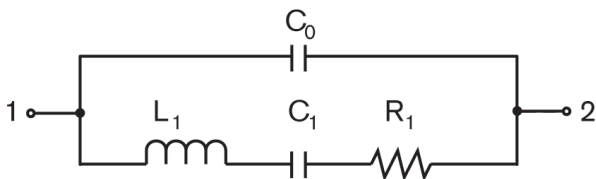

R_1 Motional Resistance L_1 Motional Inductance
 C_1 Motional Capacitance C_0 Shunt Capacitance

SUGGESTED LAND PATTERN

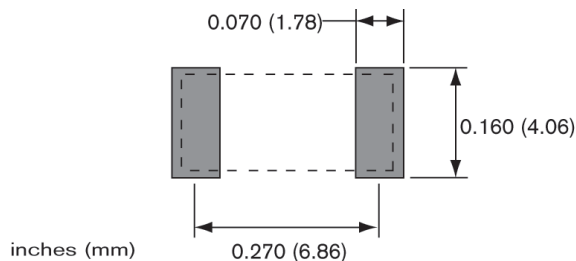

| DIM | TYP. | | MAX. | |
|-----|--------|------|-----------|------|
| | inches | mm | inches | mm |
| A | 0.315 | 8.00 | 0.330 | 8.38 |
| B | 0.140 | 3.56 | 0.155 | 3.94 |
| C | - | - | see below | |
| D | 0.045 | 1.14 | 0.055 | 1.40 |
| E | 0.060 | 1.52 | 0.070 | 1.78 |

| DIM "C" | GLASS LID | | CERAMIC LID | |
|---------|-----------|------|-------------|------|
| | inches | mm | inches | mm |
| MAX | 0.065 | 1.65 | 0.070 | 1.78 |
| SM2/SM4 | 0.067 | 1.70 | 0.072 | 1.83 |
| SM3/SM5 | 0.070 | 1.78 | 0.075 | 1.90 |

SPECIFICATIONS

Specifications are typical at 25°C unless otherwise noted. Specifications are subject to change without notice.

| Parameters | Fundamental | | | | Overtone | |
|---|--------------|-------|-------|-------|----------|------|
| | 555 k | 614 k | 1.0 M | 1.4 M | 1.8432 M | 2.1M |
| Motional Resistance, R_1 (Ω) | 600 | 275 | 500 | 775 | 300 | 475 |
| Motional Resistance, R_1 MAX | 3 k Ω | | | | | |
| Motional Capacitance, C_1 (fF) | 2.5 | 3.6 | 2.0 | 1.5 | 2.8 | 2.6 |
| Quality Factor, Q (k) | 170 | 260 | 190 | 100 | 110 | 70 |
| Shunt Capacitance, C_0 (pF) | 1.2 | 1.3 | 1.1 | 1.0 | 1.3 | 1.3 |

Calibration Tolerance¹

- ± 500 ppm (0.05%)
- ± 1000 ppm (0.1%)
- ± 10000 ppm (1.0%)

Drive Level 3 μ W MAX

Load Capacitance² 7 pF

Turning Point (T_0)² 35°C

Temperature Coefficient (k) -0.035 ppm/°C²

Note: Frequency f at temperature T is related to frequency f_0 at turning point temperature T_0 by: $\frac{f-f_0}{f_0} = k(T-T_0)^2$

Function Mode Extensional

Aging, first year 5 ppm MAX

Shock, survival 750 g, 0.3 ms, 1/2 sine

Vibration, survival 10 g RMS, 20-1,000 Hz random

Operating Temp. Range -10°C to +70°C (Commercial)
-40°C to +85°C (Industrial)
-55°C to +125°C (Military)

Storage Temp. Range -55°C to +125°C

Max Process Temperature 260°C for 20 sec.

1. Tighter tolerances available.

2. Other values available.

TERMINATIONS

| Designation | Termination |
|-------------|---------------------------|
| SM1 | Gold Plated (Lead Free) |
| SM2 | Solder Plated |
| SM3 | Solder Dipped |
| SM4 | Solder Plated (Lead Free) |
| SM5 | Solder Dipped (Lead Free) |

PACKAGING OPTIONS

CX1SM - Tray Pack
- Tape and Reel
(Reference tape and reel data sheet 10109)

HOW TO ORDER CX1SM CRYSTALS

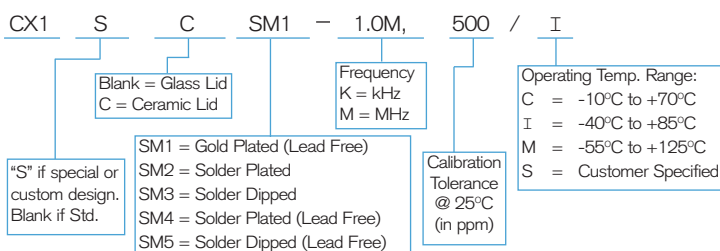

TYPICAL APPLICATION FOR A PIERCE OSCILLATOR

The low profile CX miniature surface mount crystal is ideal for small, high density, battery operated portable products. The CX crystal designed in a Pierce oscillator (single inverter) circuit provides very low current consumption and high stability. A conventional CMOS Pierce oscillator circuit is shown below. The crystal is effectively inductive and in a PI-network circuit with C_D and C_G provides the additional phase shift necessary to sustain oscillation. The oscillation frequency (f_0) is 15 to 250 ppm above the crystal's series resonant frequency (f_S).

Drive Level

R_A is used to limit the crystal's drive level by forming a voltage divider between R_A and C_D . R_A also stabilizes the oscillator against changes in the amplifiers output resistance (R_O). R_A should be increased for higher voltage operation.

Load Capacitance

The CX crystal calibration tolerance is influenced by the effective circuit capacitances, specified as the load capacitance (C_L). C_L is approximately equal to:

$$C_L = \frac{C_D \times C_G}{C_D + C_G} + C_S \quad (1)$$

NOTE: C_D and C_G include stray layout to ground and C_S is the stray shunt capacitance between the crystal terminal. In practice, the effective value of C_L will be less than that calculated from C_D , C_G and C_S values because of the effect of the amplifier output resistance. C_S should be minimized.

The oscillation frequency (f_0) is approximately equal to:

$$f_0 = f_S \left[1 + \frac{C_1}{2(C_0 + C_L)} \right] \quad (2)$$

Where f_S = Series resonant frequency of the crystal
 C_1 = Motional Capacitance
 C_0 = Shunt Capacitance

CONVENTIONAL CMOS PIERCE OSCILLATOR CIRCUIT

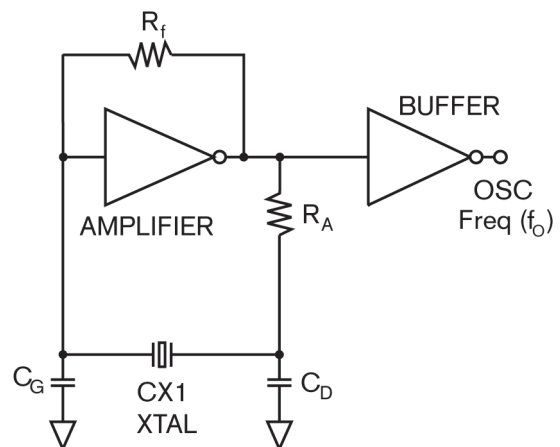

10129 - Rev C