

2200 SERIES REED RELAYS

2200 Series Reed Relays

Ideally suited to the needs of Automated Test Equipment and RF requirements. The specification tables allow you to select the appropriate relay for your particular application. If your requirements differ, please consult your local representative or Coto's Factory.

2200 Series Features

- ▶ Very small footprint (0.17 in²), high reliability reed relays
- ▶ High Insulation Resistance - 10¹² Ω available with model 2204
- ▶ High speed switching compared to electromechanical relays
- ▶ Hermetically sealed contacts for long life
- ▶ Epoxy coated steel shell provides magnetic shielding
- ▶ Optional Electrostatic Shield for reducing capacitive coupling
- ▶ Optional Coaxial Shield for 50Ω impedance and switching of fast rise time digital pulses offered on Form A
- ▶ Relay models 2200-2301, 2200-2302 are ATE industry standards
- ▶ Specifically engineered for OEM designs and maintenance of existing production fixtures
- ▶ RoHS compliant

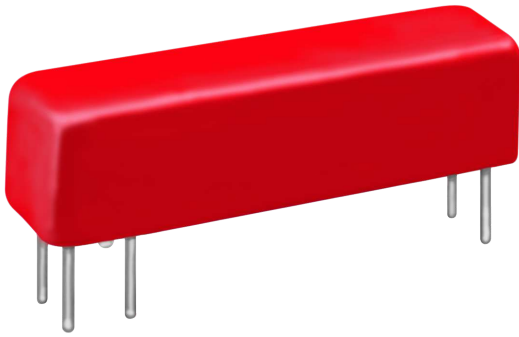

DIMENSIONS

in Inches (Millimeters)

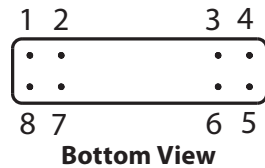
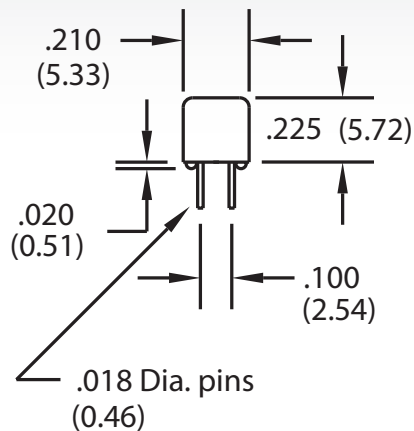
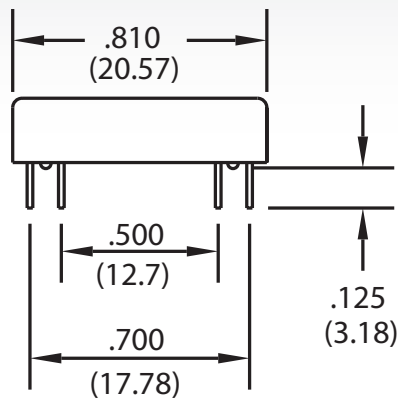

NOTE

- ▶ Model #'s 2200-2301 & 2200-2302 represent complete part numbers.

Ordering Information

Part Number	XXXX-XX-XX1	Shielding Options ²
Model Number		
2204		0=No Shielding
2211		1=Electrostatic Shield (N/A on Model #2211)
		2=Coaxial Shield (N/A on Model #2211)
Coil Voltage		
05=5 volts		
12=12 volts		
	Coil Options	
	3=use for Model #2204 (12 volt coil) and Model #2211 (5 & 12 volt coil)	
	4=use for Model #2204 (5 volt coil)	

MODEL NUMBER			2204	2211	2200-2301	2200-2302
Parameters	Test Conditions	Units	1 Form A	1 Form C	1 Form A Electrostatic Shield	1 Form A Coaxial Shield
COIL SPECS.						
Nom. Coil Voltage		VDC	5 12	5 12	5	5
Coil Resistance	+/- 10%, 25° C	Ω	370 1500	230 1500	150	150
Operate Voltage	Must Operate by	VDC - Max.	3.8 9.0	3.8 9.0	3.6	3.6
Release Voltage	Must Release by	VDC - Min.	0.4 1.0	0.4 1.0	0.5	0.5
CONTACT RATINGS						
Switching Voltage	Max DC/Peak AC Resist.	Volts	200	100	150	150
Switching Current	Max DC/Peak AC Resist.	Amps	0.5	0.25	0.5	0.5
Carry Current	Max DC/Peak AC Resist.	Amps	1.0	0.5	1.0	1.0
Contact Rating	Max DC/Peak AC Resist.	Watts	10	3	10	10
Life Expectancy-Typical ¹	Signal Level 1.0V, 10mA	x 10 ⁶ Ops.	500	100	500	500
Rated Loads		x 10 ⁶ Ops.	5	5	5	5
Static Contact Resistance (max. init.)	50mV, 10mA	Ω	0.100	0.150	0.150	0.150
Dynamic Contact Resistance (max. init.)	0.5V, 50mA at 100 Hz, 1.5 msec	Ω	0.200	0.200	0.200	0.200
RELAY SPECIFICATIONS						
Insulation Resistance (minimum)	Between all Isolated Pins at 100V, 25°C, 40% RH	Ω	10 ¹²	10 ¹¹	10 ¹¹	10 ¹¹
Capacitance - Typical Across Open Contacts	Shield Floating	pF	0.9	0.9	0.9	0.9
	Shield Guarding	pF	0.2	N/A	0.2	0.2
Dielectric Strength (minimum)	Between Contacts	VDC/peak AC	250	200	250	250
	Contacts to Coil	VDC/peak AC	250	N/A	250	250
	Contacts/Shield to Coil	VDC/peak AC	1500	1500	1500	1500
Operate Time - including bounce	At Nominal Coil Voltage, 30 Hz Square Wave	msec.	0.5 (typ.)	1.0 (typ.)	0.55 (max.)	0.55 (max.)
Release Time - Typical		msec.	0.1	2.0	0.1	0.1

Top View:
Dot stamped on top of relay refers to pin #1 location
Grid = .1"x.1" (2.54mm x 2.54mm)

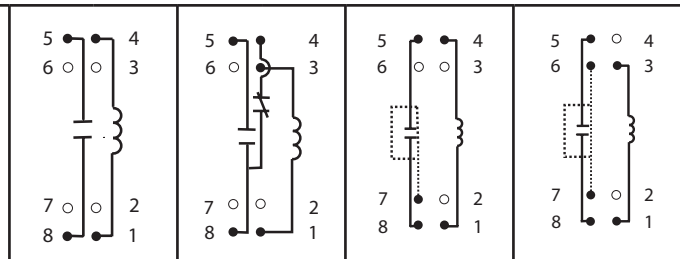

Notes:

¹ Consult factory for life expectancy at other switching loads.

² Model 2204, pin #7 is tied to optional electrostatic shield, pins #6 & #7 are tied to optional coaxial shield.

Environmental Ratings:

Storage Temp: -35°C to +100°C; Operating Temp: -20°C to +85°C; Solder Temp: 270°C max; 10 sec. max

All electrical parameters measured at 25°C unless otherwise specified.

Vibration: 20 G's to 2000 Hz; Shock: 50 G's